

**SUBMITTAL FOR:**

**CSXT – GENESEE RIVER SITE  
ROCHESTER, NY**

**CONSTRUCTION WATER MANAGEMENT PLAN  
(CWMP)**

**SUBMITTED TO:**

**AMEC EARTH & ENVIRONMENTAL, INC.**

One Plymouth Meeting, Suite 850  
Plymouth Meeting, PA 19462-1308

**SUBMITTED BY:**

**D.A. COLLINS ENVIRONMENTAL SERVICES**

101 Route 67, PO Box 191  
Mechanicville, New York 12118-0190  
Ph. 518-664-9855 / Fax 518-664-9609



*A Proud Member of the D.A. Collins Companies*

**AUGUST 25, 2004**

**Table of Contents**

1.0 Overview ..... 2

2.0 Collection & Handling of Construction Water ..... 2

    2.1 Collection & Transfer ..... 2

    2.2 Storage ..... 3

    2.3 Construction Water Minimization ..... 3

3.0 Water Treatment & Discharge ..... 4

    3.1 Discharge Permit..... 4

    3.2 Treatment Technology ..... 4

    3.3 Confirmatory Analysis..... 5

4.0 Waste Disposal..... 5

    4.1 Construction Water ..... 5

    4.2 Solid Wastes..... 5

5.0 Contingency Measures ..... 6

    5.1 Significant Storm Events ..... 6

    5.2 Alternative Discharge Testing ..... 6

Appendix 1 – Treatment System Specifications ..... 7

## **1.0 Overview**

The Construction Water Management Plan (CWMP) shall be utilized to manage the collection, handling, treatment, and disposal of construction water which is generated on-site as a result of direct contact with pure product or contaminated sediments.

A copy of this CWMP shall be maintained on-site at all times and updated as necessary to maintain compliance with all applicable permits.

This CWMP represents the minimum standard to which contaminated water will be managed and treated. In the event that the proposed treatment technologies do not adequately achieve the stipulated discharge limits, additional methods or components will be implemented to upgrade the performance of this plan.

## **2.0 Collection & Handling of Construction Water**

### **2.1 Collection & Transfer**

Any water identified as potentially contaminated by direct contact with contaminated sediments shall be collected for management under the CWMP. Typical construction water (CW) could include, but is not limited to, the following:

- Water generated from dewatering sediment activities.
- Runoff from contaminated sediment stockpiles.
- Standing water with visible sheen, product, or other contaminants.
- Runoff from contaminated surfaces.
- Equipment or personal decontamination water.

Construction water management is particularly important within the SSA. Due to the sizable surface area and potential to collect rainwater, a semi-permanent collection system has been installed.

As detailed on the project drawings, the SSA will be approximately 40,000 ft<sup>2</sup> and constructed with an asphalt surface and bordered by 6" curbs. The SSA will be graded to promote runoff to two collection sumps. The collection sumps are precast concrete catch basins and measure 4' deep with a 30" inside diameter. A submersible pump, capable of pumping 30 – 40 gpm and 1" polyethylene water line shall be installed in each sump to transfer the collected CW to the water treatment system under average meteorological conditions. Each submersible pump shall be equipped with a float sensor to activate the pump when runoff is collected.

The NYS Standards and Specifications for Erosion and Sediment Control indicate that a 5 year, 24 hr rainfall event totaling 3.1 inches can be reasonably expected in the Rochester area during this project. Accordingly, the collected runoff over the SSA (40,000 ft<sup>2</sup>) during the 24 hour period may be as much as 77,293 gallons. During a fairly constant precipitation event, approximately 54 gallons per minute can be expected to collect in the collection sumps. The installed collection and pumping system is capable

of a combined pumping capacity between 60 and 80 gpm and is expected to adequately manage runoff from the SSA.

Please refer to section 5.0 of this CWMP for contingency measures in mitigating the effects of significant storm events.

## **2.2 Storage**

Storage of both treated and untreated CW will be maintained with 22,000 gallon frac tanks located within the work area limits. The exact placement of the frac tanks will be dependent upon the conditions at the site, the location of the CW, and available space. Frac tanks will be relocated periodically to provide best possible placement or to relocate them away from areas scheduled for work. The anticipated placement is shown on Drawing DAC-1 provided under separate cover.

Frac tanks will be dedicated as either Treated or Untreated Storage to prevent cross contamination of treated water by residuals in a contaminated tank. Untreated water shall not be placed into a Treated Water tank. It is anticipated that two Untreated Storage tanks and two Treated Storage tanks shall be maintained onsite. Additional frac tanks may be brought onsite when necessary.

## **2.3 Construction Water Minimization**

Where possible, the volume of CW shall be minimized through the utilization of engineering controls, task sequencing, and other methods. Areas which have the potential to generate large volumes of CW shall be closed, covered, or otherwise protected (where practical) to minimize the amount of water contacting contaminated surfaces. Water minimization methods may include the following:

- Tarpaulin or poly sheeting covers over contaminated stockpiles.
- Upgradient stormwater diversion to prevent overland flow into contaminated sediment storage areas.
- Control and minimization of contractor's water utilization during equipment decontamination and related activities.

## 3.0 Water Treatment & Discharge

### 3.1 Discharge Permit

It is assumed that the Agency will provide formal authorization of this CWMP as part of the underlying remedial action approval process. In general, contaminated water will be treated to remove contaminants of concern (primarily VOCs) and suspended solids prior to discharge to the Genesee River, in accordance with stipulated discharge criteria to be issued by NYS DEC. Based upon the discharge criteria developed by the Agency, modifications to the methods and technologies presented herein may become necessary. This CWMP will be amended as necessary to address any variations or upgrades.

For permitting purposes the Agency should assume the following parameters:

1. Estimated discharge flow rate: 50 - 100 gpm
2. Estimated total volume of water (life of project): 300,000 – 500,000 gallons
3. Discharge point: Genesee River
4. Discharge schedule: Life of project (8/04-10/04)

### 3.2 Treatment Technology

Treatment of CW will be performed using D.A. Collins' portable 100 gpm water treatment system. The trailer mounted system is equipped with the following technologies. Equipment specifications are attached in Appendix 1.

- Pre-treatment particulate filtration (2 x 100 gpm bag filters)
- Preliminary and secondary treatment vessels (2 x 1,800 lb. media vessels)
- Post-treatment particulate filtration (1 x 100 gpm bag filter)
- Pump: The system is equipped with a 100 gpm pump but can also operate with a variety of accessory pumps up to 100 gpm.
- Configuration: The vessels and bag filters can be configured as needed for treatment in parallel or series, or a combination thereof. Typical configuration is primary particulate filtration in parallel, followed by media filtration in series, followed by the last particulate filter.
- Filtration Media: The media vessels will be filled with granular activated carbon. Other media may be utilized depending upon the nature of the CW.

Additional technologies which may be added as needed could include, but are not limited to the following. Installation and operation of additional system components will be dependent upon the discharge criteria, the nature of the CW, and the performance of the baseline system described above.

- Oil water separation
- Polymer flocculation
- Air stripping

### **3.3 Confirmatory Analysis**

Treated CW shall be submitted for laboratory analysis to confirm successful treatment. Sample frequency shall be 1 sample per 22,000 gallon batch. Periodic sampling may also be performed at D.A. Collins' discretion to monitor system performance and the condition of filtration media. Analysis parameters will include the following, as directed by the Agency:

- Oil & Grease
- EPA Method 8260 (full list)
- Total Suspended Solids
- pH

Treated CW will not be discharged until sample analysis has demonstrated compliance with the permit requirements. D.A. Collins will be provided sufficient time to review any lab reports prior to discharge.

## **4.0 Waste Disposal**

### **4.1 Construction Water**

In the event that D.A. Collins elects to dispose of water at an off-site TSDF, the facility information will be submitted to the Engineer for review and approval prior to any waste shipments. No wastewater will be shipped for off-site disposal without Engineer approval.

### **4.2 Solid Wastes**

Solid wastes resulting from the operation and maintenance of the water treatment system and storage tanks will be disposed of with outgoing bulk wastes. Solid wastes from the system operation will include:

- Spent bag filters
- Spent activated carbon
- Sediments and sludges from storage tanks and vessels
- Poly sheeting, liner material, PPE, sampling media, and other disposables

Disposition of solid waste will depend upon the current phase of the project and the TSDFs selected for waste management.

## 5.0 Contingency Measures

### 5.1 Significant Storm Events

Due to the large surface area of the SSA and requirement to collect the rainwater in its entirety, additional controls may be required during significant storm events. Each event shall be evaluated individually; however the following may be used as a baseline for determining appropriate actions.

The rational method is used to determine peak flow rates for drainage areas less than 20 acres. The peak flow rate (Q) is a function of the Runoff Coefficient (C), Rainfall Intensity (i) and Surface Area (A) as shown below:

$$Q = C*i*A$$

The runoff coefficient for asphalt surfaces is estimated at 0.95 and a significant storm event may be expected to produce a rainfall intensity of 2.0" per hour. As such the peak flow rate for a significant storm event may potentially peak at 784 gpm.

If it is anticipated that rainfall event of this magnitude is expected, additional pumps and storage tanks shall be placed into service. For a storm event similar to that described above, two additional 3" pumps shall be placed into service (one in each sump). A standard 3" pump is capable of pumping approximately 400 gpm (depending pipe length and head), thus increasing the system capacity to roughly 860-880 gpm. The appropriate pump size shall be adjusted as necessary with respect to each individual storm event.

### 5.2 Alternative Discharge Testing

In the event of a significant rain event, and depending on the observed water quality, D.A. Collins may propose alternate testing and treatment options including but not limited to the following. These options would be reviewed with the Engineer and the Agency, for subsequent approval, prior to implementation.

- Composite sampling of several treated batches to expedite laboratory analysis.
- Single or composite samples of untreated batches to determine the need for treatment and potentially discharge without treatment.
- Abbreviated treatment (removal of suspended solids only, pH adjustment, etc.)
- Continuous treatment processing and periodic testing.
- Direct discharge of collected runoff of acceptable quality.

## Appendix 1 – Treatment System Specifications



## BF 100 Filter

### Features

- Manifold connections are 2" 150lb flanges
- Single bag filter
- Bag filter for high solids holding capacity
- Replaceable bag filters from 100 to 1 micron nominal rating
- No moving parts
- Mounted on the portable trailer

### Technical Information

- Bag filter chamber connect in parallel
- Units are fitted with bleed valves and pressure gauges
- System can stand alone for sediment removal or be used in combination with filter equipment
- Footprint: 48" long x 36" wide x 66" high
- Dry weight: 500 pounds

### Materials Specifications

- Chambers constructed out of 304 stainless steel
- Piping constructed out of 304 stainless steel
- Each bag filter chamber holds one (1) 7" x 30" double stitched filter bag
- Maximum operating pressure is 125 psi
- Stainless steel inlet and outlet manifolds



- NOTES:
- 1) VESSEL VOLUME - 553 GALLONS  
- 74 CUBIC FEET
  - 2) EMPTY VESSEL WEIGHT - 1007 LBS
  - 3) OPERATING WEIGHT - 4441 LBS (APPROX)
  - 4) OPERATING PRESSURE - 75 PSI (MAX)
  - 5) OPERATING TEMPERATURE - 100° F (MAX)

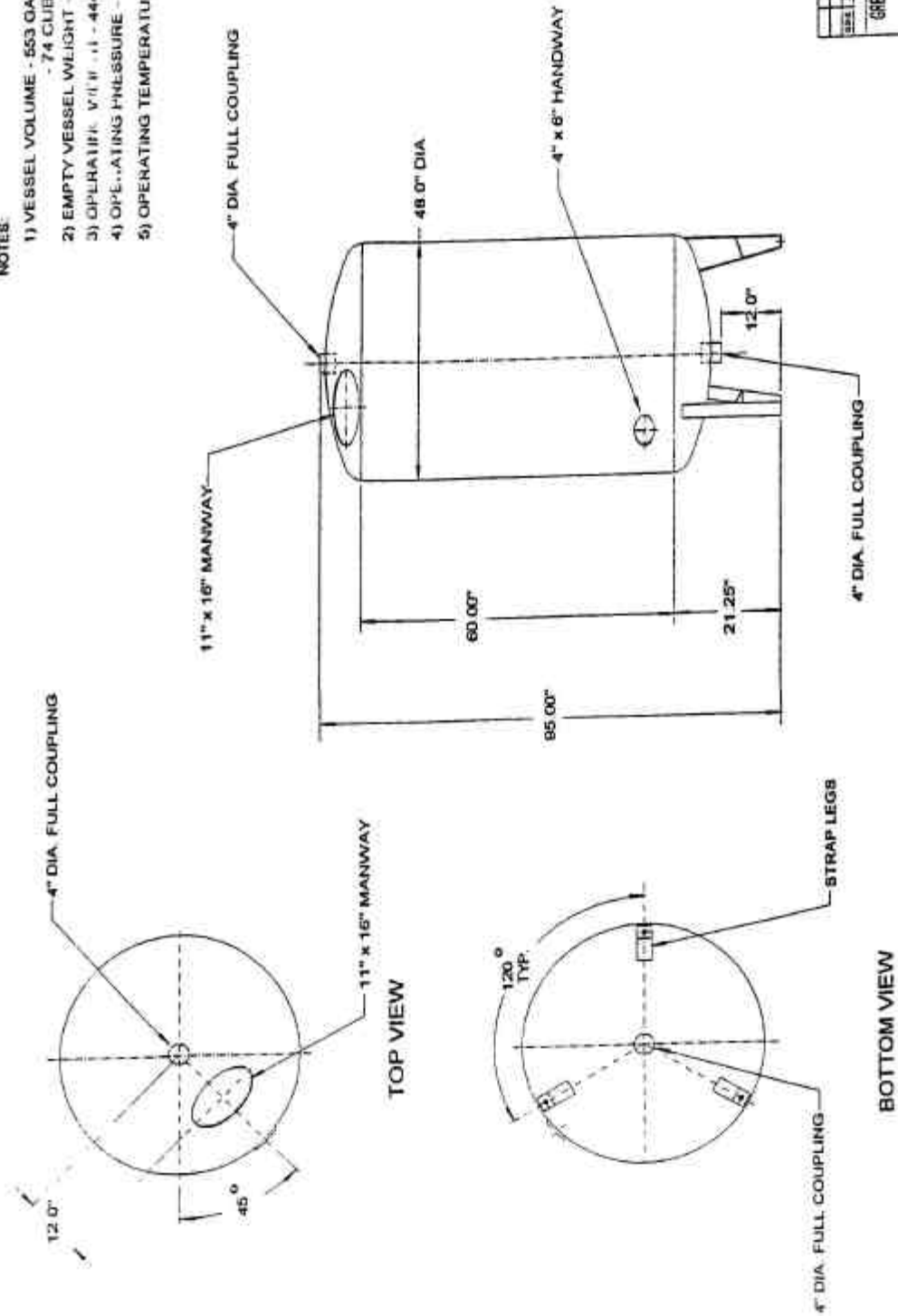

DATE	DESCRIPTION	BY

GREAT LAKES CARBON TREATMENT, INC.  
2700 AL S. 131 1/2 E.  
MADISON WI 53715

LIQUID PHASE  
1800 LBS  
STEEL VESSEL

REV. NO. 1  
DATE 11/11/04  
BY J. COLLINS  
CHECKED BY J. COLLINS  
DATE 11/11/04

THIS DRAWING IS THE PROPERTY OF GREAT LAKES CARBON TREATMENT, INC. IT IS TO BE USED ONLY FOR THE PROJECT AND SITE SPECIFICALLY IDENTIFIED HEREON. IT IS NOT TO BE REPRODUCED, COPIED, OR TRANSMITTED IN ANY FORM OR BY ANY MEANS, ELECTRONIC OR MECHANICAL, INCLUDING PHOTOCOPYING, RECORDING, OR BY ANY INFORMATION STORAGE AND RETRIEVAL SYSTEM, WITHOUT THE WRITTEN PERMISSION OF GREAT LAKES CARBON TREATMENT, INC.

**SPECIFICATIONS FOR THE  
GLC 1800S# LIQUID PHASE  
GRANULAR ACTIVATED CARBON  
UNIT.**

1. Use: This unit is used to remove liquid phase contaminants such as Benzene, Ethyl Benzene, Toluene, Xylene and Naphthalene from a stream of influent water, usually ground water. Two or more vessels are used in series, with a lead vessel, sample port and a vessel to polish the effluent water. When tests from the sample port show the lead vessel is used up, the flow is shut off and that vessel is refilled with fresh carbon. Then the flow is routed to the second vessel first, and then back through the new carbon. The new carbon vessel is now the polish vessel and the old polish is now new lead vessel.
2. Carbon Capacity: 1800# of Virgin Grade Granular Activated Liquid Phase Carbon per vessel. A 20 % volume allowance for fluidizing the carbon during backflushing is provided.
3. Nominal Flow Rate: 60 GPM
4. Empty Bed Contact Time: Calculations: 1 Steel Vessel: 553 Gal./60 GPM = 9.22 Minutes  
  
EPA guideline for minimum Contact Time is: 7.5 Minutes
5. Hydraulic Loading: 4.777 Gal./Sq. Ft.  
Hydraulic Loading = Flow Rate/Bed Area =  
60 GPM/12.56 Sq. Ft.  
= 4.777 Gal. / Sq. Ft.
6. Volume: One Vessel: 553 Gal. or 74 Cubic Feet
7. Description of Vessel:  
Flow Direction: Downflow  
Top Influent Connection, Male Camlock  
Top Pressure Gauge  
Top Air Eliminator  
Top Distributor, Upon request  
1800 Pounds of Virgin Grade Liquid Phase Carbon  
Bottom Distributor: 8 Slotted Fingers, .015 Slots  
Material: Steel  
Finish: Lined and Primed Steel  
Diameter: 48 Inches  
Legs: 3 Strap Legs, 1/4" x 2 1/2" x 29", at 120 Degrees.  
Top Design: .25" Thick dish with 11" x 15" Manway and 4" Full coupling welded in.  
Bottom Design: .25" Thick dish with 4" Full coupling welded in.  
Side Design: .25" Steel rolled, Handhole 4" x 6" above bottom weld.  
Weight: 1007 Lbs.  
Floor to Bottom Coupling: 12 Inches  
Floor to Bottom Weld or Rib: 21 1/4 Inches  
Bottom Weld to Top Weld: 60 Inches  
Height: 95 Inches.  
Volume: 553 Gallon or 74 Cubic Feet.

8. Lining:  
Internal surfaces shall be primed with TNEMEC 20-1211 Red or 20-1255  
Beige primer to a thickness of 4.0 mils.
9. Exterior Finish:  
Paint exterior with Blue Empire 28B6 paint.
10. Operating Temperature: 50 to 120 Degrees F.
11. Operating Pressure: 75 PSI.
12. Carbon: Virgin Grade Liquid Phase Carbon  
  
Mesh Size: 8 x 30  
Iodine Number: 950 Minimum  
Carbon Tetrachloride Activity: 62% Minimum  
Apparent Density, Lbs./Cu. Ft.: 30 Average  
Total Ash Content: 12% Maximum  
Hardness (Ball Abrasion): 90 Average  
Reactivated carbon available upon request.
13. Pressure Drop: Less than 5 psi.

*Pump -  
2300 1φ 7.5Hp  
starting = 2 amp  
Running 2.3*

Series 2000 Performance Curves – 60 Hz, 3500 RPM

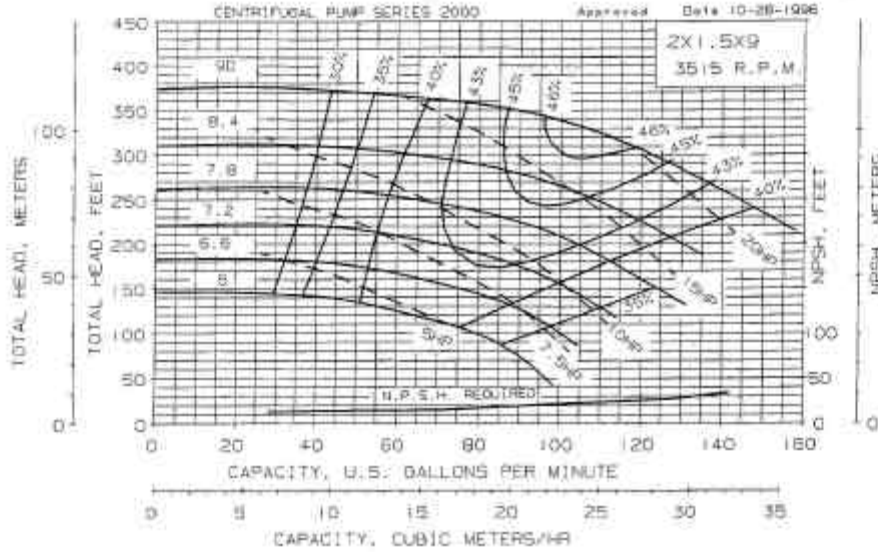

Impeller Code	Size	Standard HP
A	9	20
B	8.4	15
C	7.8	15
D	7.2	10
E	6.6	7½
F	6	5

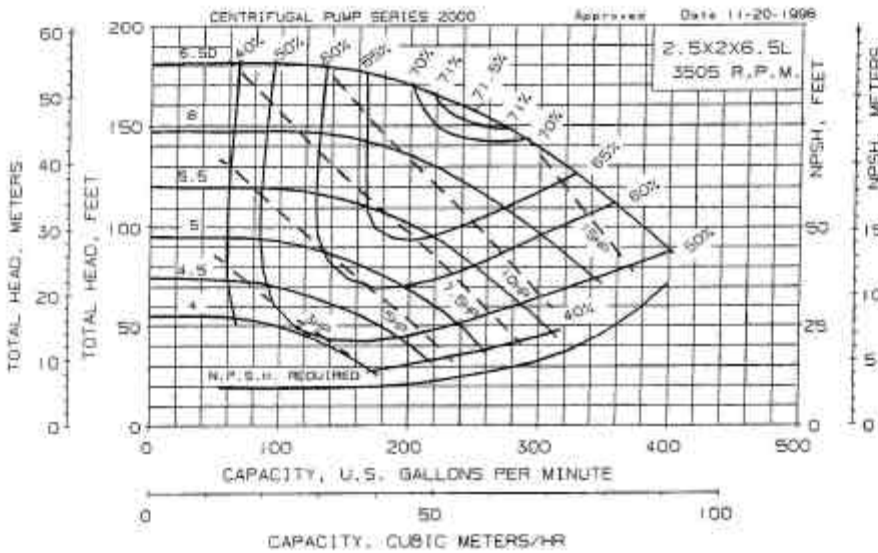

Impeller Code	Size	Standard HP
A	6.5	15
B	6	15
C	5.5	10
D	5	7½
E	4.5	5
F	4	3