

**ENGINEERING REPORT AND OPERATION,
MONITORING AND MAINTENANCE PLAN**

FOR

45 KEAN STREET

WEST BABYLON, NEW YORK

**NYSDEC VOLUNTARY CLEANUP PROGRAM
SITE # V00242-1**

**FOR SUBMITTAL TO THE
NEW YORK STATE
DEPARTMENT OF ENVIRONMENTAL CONSERVATION**

PREPARED BY

***FPM* group**

**909 MARCONI AVENUE
RONKONKOMA, NEW YORK 11779**

**ENGINEERING REPORT AND
OPERATION, MONITORING AND MAINTENANCE PLAN**

Prepared for

Facility: 45 Kean Street
West Babylon, New York
NYSDEC VCP # V00242-1

FPM File No: 891-06-01

I certify that the remediation activities described herein were implemented and completed in substantial accordance with the New York State Department of Environmental Conservation-approved Remedial Action Work Plan and associated documents, as described herein.

New York State Professional Engineer # _____

Signature

It is a violation of Article 130 of the New York State Education Law for any person to alter this document in any way without the express written verification or adoption by a New York State licensed land surveyor or engineer in accordance with Section 7209(2), Article 130, New York State Education Law.

Prepared by

FPM Group
909 Marconi Avenue
Ronkonkoma, NY 11779
(Tel) 631-737-6200
(Fax) 631-737-2410

FPM

TABLE OF CONTENTS

<u>Section</u>	<u>Title</u>	<u>Page No.</u>
1.0	Introduction	1-1
2.0	Air Sparging/Soil Vapor Extraction Remediation System	2-1
2.1	AS/SVE System Installation.....	2-1
2.1.1	AS/SVE Well Installation.....	2-1
2.1.2	AS/SVE System Description.....	2-1
2.2	AS/SVE System Startup.....	2-2
2.2.1	AS/SVE System Performance Measurements.....	2-2
2.2.2	SVE Emissions Monitoring.....	2-3
2.3	AS/SVE System Operation, Monitoring and Maintenance Plan.....	2-9
3.0	Groundwater Monitoring	3-1
3.1	Summary of Existing Groundwater Conditions.....	3-1
3.2	Offsite Groundwater Monitoring Well Installation.....	3-3
3.3	Groundwater Monitoring and Reporting Plan.....	3-3
3.1.1	Groundwater Monitoring Procedures.....	3-4
3.1.2	Groundwater Monitoring Reporting.....	3-4
3.1.3	Criteria for Termination of Groundwater Monitoring.....	3-4
4.0	Quality Assurance/Quality Control Procedures	4-1
4.1	Sampling Equipment Decontamination Procedures.....	4-1
4.2	Chain-of-Custody Procedures.....	4-1
4.3	QA/QC Samples.....	4-1
5.0	Remedial Action Objectives	5-1
6.0	References	6-1

APPENDICES

A	Boring Logs
B	System Process Instrumentation Diagrams
C	Equipment Specifications
D	Laboratory Analytical Reports

SECTION 1.0 INTRODUCTION

This Engineering Report has been prepared by FPM Group (FPM) to document the installation of the soil vapor extraction (SVE) and air sparging (AS) system at New York State Department of Environmental Conservation (NYSDEC) Voluntary Cleanup Program (VCP) Site #V00242-1, identified as the 45 Kean Street Site, located in West Babylon, New York. An Operation, Monitoring and Maintenance (OM&M) Plan and a groundwater monitoring plan are also provided herein. The Site location is shown on Figure 1.1.

The AS/SVE system was installed between January and April 2008 in accordance with the NYSDEC-approved February 2007 Pilot Test Report for the 45 Kean Street Site. Figure 1.2 depicts the Site and the remediation system layout.

The AS/SVE system was installed on the east portion of the Site. Previous investigations indicate that soil impacted by volatile organic compounds (VOCs) was formerly present onsite in a drywell (former DW-1) located in the vicinity of the AS-1/SVE-1 and AS-2/SVE-2 wells. Impacted soils in the drywell were removed to 18 feet below grade (the approximate depth of the water table) in 1996. Endpoint soil sample results from the former DW-1 indicated that VOC-impacted soil remained present below the water table surface. The former DW-1 drywell was backfilled and decommissioned in 1996 and a replacement drywell DW-01 was installed at a different location in September 2000.

Additional soil samples were subsequently collected throughout the Site at various depths; none of the samples contained VOCs above the NYSDEC Objectives. Based on these data, VOC-impacted soil appeared to be confined to below the water table in the vicinity of the former DW-1 location.

Groundwater samples were also collected throughout the Site at varying depths, with the most recent sampling occurring in August 2005. The results indicated that VOC impacts were present only in the shallow groundwater on the eastern edge of the property.

Based on these findings, the NYSDEC required that remediation of the impacted soil and groundwater be performed. The selected remedy for the Site included the installation of an AS/SVE system to remediate onsite groundwater and soil. A pilot test was performed in September 2006. The results of the test were documented in our February 2007 Pilot Test Report. The Pilot Test Report was approved by the NYSDEC on March 12, 2007. The AS/SVE system was subsequently installed as documented herein.

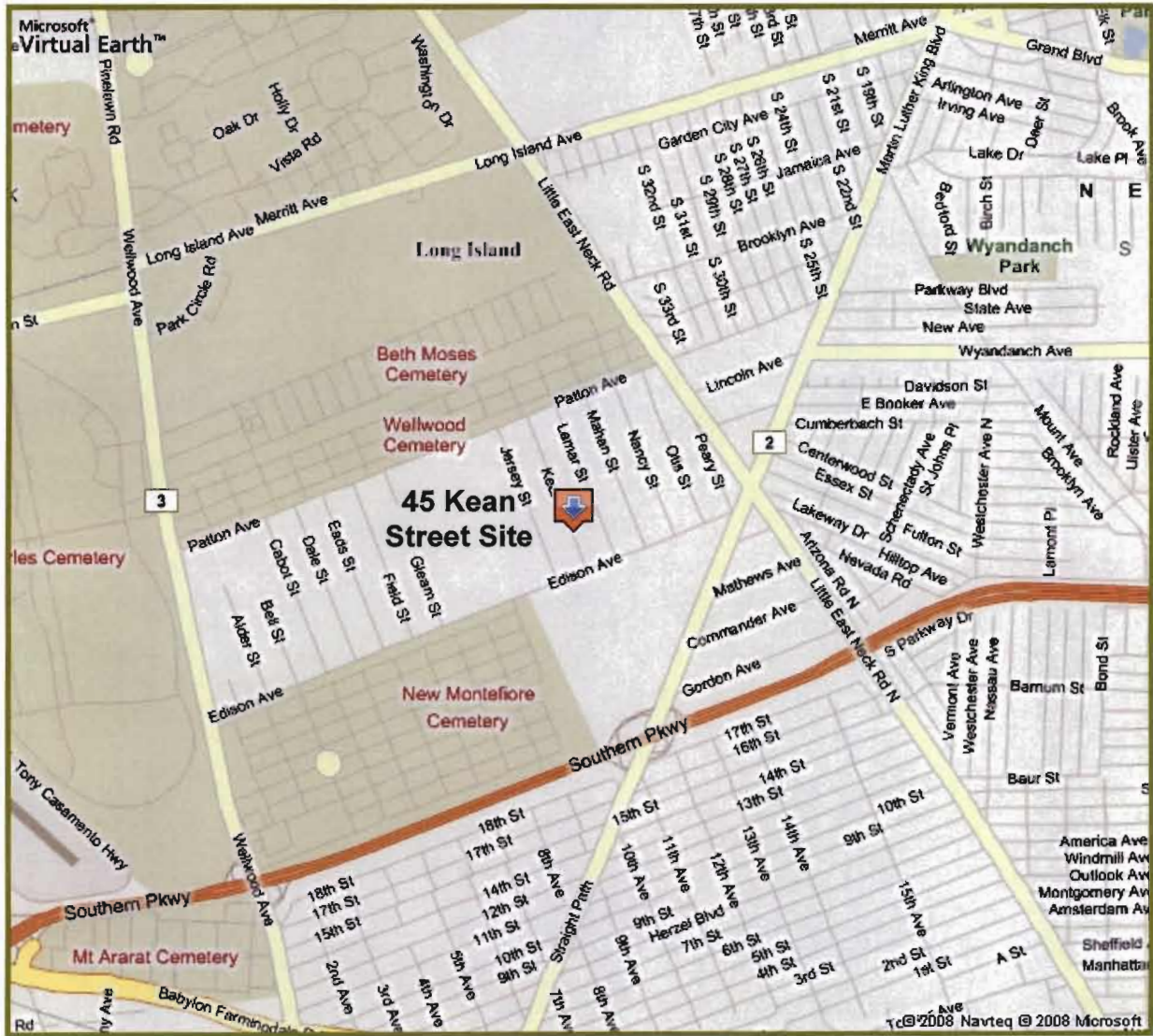

FPM GROUP

FIGURE 1.1

SITE LOCATION

45 KEAN STREET
WEST BABYLON, NEW YORK

Drawn by: TAC	Checked By: JSB	Date: 7/16/08
---------------	-----------------	---------------

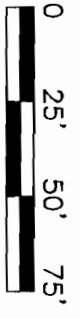
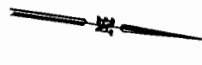
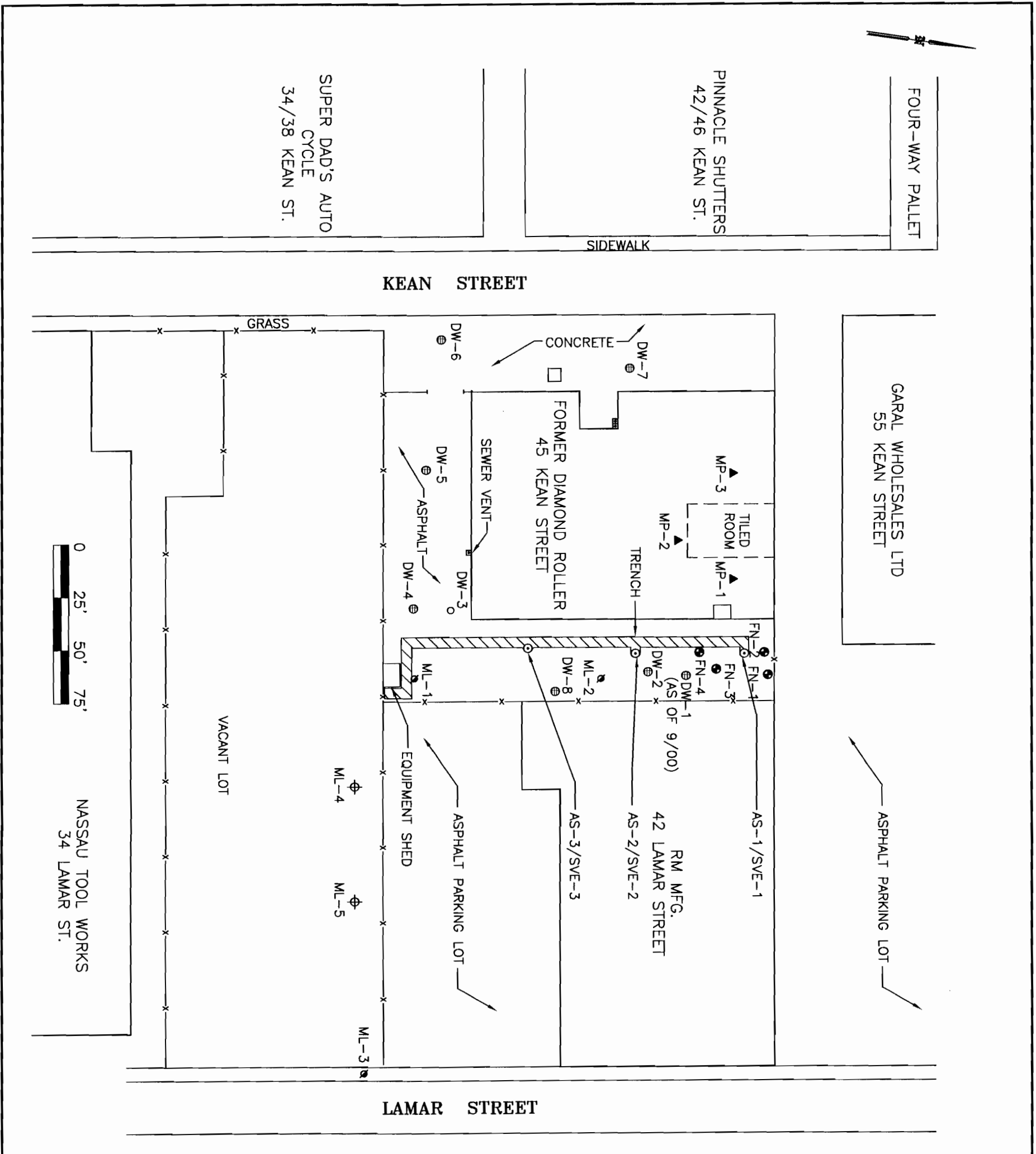

- LEGEND:**
- - MONITORING WELL LOCATION
 - - MULTI LEVEL MONITORING WELL LOCATION
 - ⊕ - OPEN-GRATE DRYWELL LOCATION
 - - OVERFLOW DRYWELL
 - ⊖ - CO-LOCATED AS AND SVE WELLS
 - ▲ - SUB-SLAB MONITORING POINT

<p>FPM GROUP</p>
<p>FIGURE 1.2</p> <p>REMEDIATION SYSTEM LAYOUT</p> <p>45 KEAN STREET</p> <p>NORTH BABYLON, NEW YORK</p>
<p>Drawn By: J.S. Checked By: S.D. Date: 10/8/08</p>

SECTION 2.0 AIR SPARGING/SOIL VAPOR EXTRACTION REMEDIATION SYSTEM

The following section details the installation of the AS/SVE remediation system approved by the NYSDEC. This section also includes information concerning the system startup, performance, emissions monitoring, and operation and maintenance. The remediation system layout is shown on previously-presented Figure 1.2.

2.1 AS/SVE System Installation

The components of the AS/SVE system were installed between 2006 and 2008. FPM provided oversight of system installation and performed subsequent operation, monitoring and maintenance.

2.1.1 AS/SVE Well Installation

Installation of the AS and SVE wells was performed by Land, Air, Water Environmental Services, Inc. under the supervision of FPM personnel. The well installation was conducted in July 2006 and the wells were subsequently used for pilot-testing purposes.

The AS and SVE wells are constructed of two-inch diameter Schedule 80 PVC. The AS wells are screened from 30 to 32 feet below grade. The SVE wells are screened from 8 to 14 feet below grade. Well construction diagrams for the AS and SVE wells are included in Appendix A.

2.1.2 AS/SVE System Description

Installation of the AS/SVE system was performed by EnviroTrac, Ltd (EnviroTrac) and was overseen by FPM. EnviroTrac coordinated the procurement and installation of the remediation system equipment. Installation of the remediation system, including the construction of well manways, subsurface piping, and the above-grade components, was conducted between January and April 2008.

The installation of the subsurface system piping was accomplished by the emplacement of Schedule 80 PVC piping in subsurface trenches extending from each well to the remediation system enclosure. The piping for the AS and SVE systems is two inches in diameter and was selected based upon the specifications of the operating equipment. Galvanized two-inch pipe is utilized in the construction of the aboveground portion of the AS manifolds due to the anticipated heat associated with compressed air flow.

The operating equipment utilized for the AS system includes a Becker model KDT 3.60 5.0-horsepower 208-volt three-phase totally-enclosed fan-cooled (TEFC) rotary-vane compressor a high-

temperature shut-off switch, air flow gauges, pressure gauges, a galvanized metal manifold, and an associated control panel with timer.

The equipment utilized for the SVE system includes a 8.45-horsepower, 220-volt, single-phase regenerative blower (Nash Elmo model 2BH1 830 A293), a moisture separator equipped with an explosion-proof high water safety switch, an air filter, a manifold, an air flow meter, vacuum gauges, an effluent stack, and an associated control panel. The control panel is also equipped with an electrical interlock that prevents the AS system from operating when the SVE system is offline. The system's effluent stack was completed to a height of approximately 20 feet above grade, and is outfitted to allow the use of carbon treatment, if required.

Process instrumentation diagrams and equipment specifications are included in Appendices B and C, respectively. As-built system drawings showing the equipment layout in the shed, the piping layout from the wells to the equipment shed, and the AS and SVE wells and appurtenances are also included in Appendix B.

2.2 AS/SVE System Startup

On June 26, 2008, the remediation system was placed online by FPM and EnviroTrac. The system was monitored until system vacuums, pressures, and airflow stabilized. A calibrated photoionization detector (PID) was also utilized to monitor effluent emissions. Slight modifications (valve adjustments) were made to both the AS and SVE operating parameters to optimize system performance. The AS wells are operated in a pulsed manner on a timer-controlled cycled program, with each well operating independently for a two-hour period, followed by a two-hour period in which the AS compressor is off. Upon completion of this eight-hour cycle, the AS compressor is automatically started and the cycle is repeated. All three SVE wells are operated continuously.

2.2.1 AS/SVE System Performance Measurements

The remediation system is equipped with several airflow, pressure, and vacuum gauges. These gauges have been installed to assist in optimizing system performance and also to monitor system component operation. The process instrumentation diagrams prepared for the system (included in Appendix B) show a schematic layout of all gauges and associated valves.

A system logbook has been prepared and is kept at the Site for operator reference. The logbook contains operating logs for recording system parameters from the various gauges and includes figures showing the system wells and equipment configuration.

AS/SVE system monitoring has been conducted on a monthly basis. Information summarizing the monitored system parameters to date is included in Table 2.2.1.1. These data indicate that the minimum air flows for the AS wells (17 standard cubic feet per minute, or scfm, based on the pilot test) are being exceeded, with actual airflows ranging from 21 to 24 scfm. The air pressure applied to the AS wells (5 to 7 pounds per square inch, or psi) is less than the pilot test pressure (10 psi). These data suggest that the AS optimum radius of influence (ROI) is either met or exceeded, resulting in a sufficient AS treatment zone.

To further evaluate the AS ROI, pressure readings were recorded at monitoring wells FN-1 through FN-4, and ML-2 during operation of the AS system. The following positive pressures were noted: 2 inches of water at FN-2, 1.5 inches of water at FN-1, 1 inch of water at FN-3, and 0.2 inches of water at FN-4 and ML-2. Based on the pressures noted in these wells, the AS system appears to be providing a sufficient ROI (approximately 23 feet), as estimated in the Pilot Test Report.

The SVE monitoring data indicate that the applied vacuums at the three SVE wells range from 18 to 22 inches of water, which exceed the optimum applied vacuum of 10 inches of water determined in the pilot test to result in sufficient overlap of the ROIs. Therefore, the actual ROIs for these SVE wells are likely larger than observed in the pilot test.

Vacuum measurements have been recorded at monitoring points MP-1 through MP-3 during operation of the AS/SVE system to further evaluate the SVE ROI. These data are shown graphically on Figure 2.2.1.1 and indicate that induced vacuum has been observed at all three monitoring points, which are located up to 85 feet from SVE-1. These observations confirm that beneath the building's concrete slab an SVE ROI of at least 85 feet is observed. MP-3 is located 38 feet from the western wall of the building. Based on the location of MP-3 and the observed vacuum at this monitoring point, it appears that the SVE wells are inducing a vacuum beneath the entire Site building.

2.2.2 SVE Emissions Monitoring

An evaluation of the anticipated SVE effluent emissions was initially performed during the remediation system pilot test conducted in 2006. Emissions data were evaluated in accordance with the NYSDEC Division of Air Resources (DAR) Program Policy (DAR-1) entitled, "Guidelines for the Control of Toxic Ambient Air Contaminants" (NYSDEC, 1997). The effluent data were used to calculate the various potential impacts, as described in DAR-1, which were then compared with the corresponding Annual Guideline Concentration (AGC) or Short-Term Guideline Concentration (SGC) values, as applicable. The results of the initial emissions testing are documented in the Pilot Test Report.

TABLE 2.2.1.1
 SOIL-VAPOR EXTRACTION/AIR SPARGE SYSTEM OPERATING LOG
 45 KEAN STREET SITE
 WEST BABYLON, NEW YORK

Date	SVE System						AS System						Comments/ Observations		
	Vacuum Before Air Filter ("H ₂ O)	Vacuum After Air Filter ("H ₂ O)	Vacuum @ Well SVE-1 ("H ₂ O)	Vacuum @ Well SVE-2 ("H ₂ O)	Vacuum @ Well SVE-3 ("H ₂ O)	Total System Flowrate (scfm)	Discharge Analysis w/PID (ppm)	Compressor Discharge Pressure (psi)	Pressure @ Well AS-1 (psi)	Pressure @ Well AS-2 (psi)	Pressure @ Well AS-3 (psi)	Flow To Well AS-1 (scfm)		Flow To Well AS-2 (scfm)	Flow To Well AS-3 (scfm)
6/26/2008	32	34	18	19	21	320	0.5	7	7	5	5	21	23	22	120
7/24/2008	33	35	20	18	19	335	0.4	7.5	7	4.5	5.5	23	23	22	115
8/21/2008	35	37	19	19	20	330	0	7	6.5	5	5.5	24	22	22.5	110
9/19/2008	33	35	19	20	22	330	0	7.5	7	5	5	23	23	22	110
10/9/2008	33	35	19	19	21	325	0	7.5	6.5	5	5	22	23	22.5	105
11/13/2008	34	36	20	20	22	335	0	7.5	6.5	4.5	5.5	23	23	22.5	100

Notes:

- "H₂O = inches of water
- scfm = standard cubic feet per minute
- ppm = parts per million
- psi = pounds per square inch

Figure 2.2.1.1.1
Monitoring Point Vacuum Measurements
45 Kean Street Site
West Babylon, New York

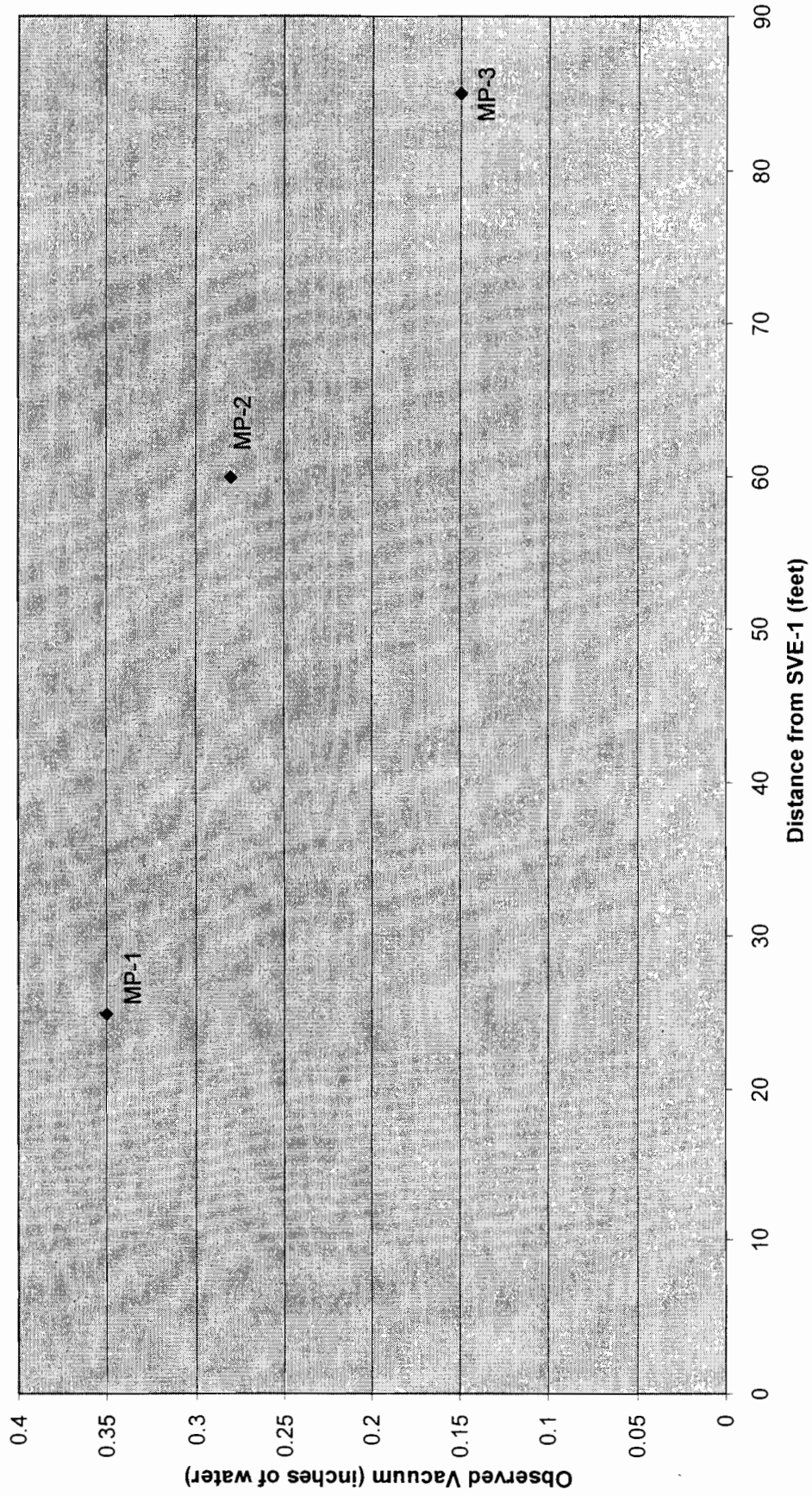

Based upon the SVE effluent emissions data collected during the pilot test, 1,1,1-trichloroethane (1,1,1-TCA), chloroethane, and tetrachloroethylene (PCE) were the VOCs detected at the highest concentrations. Other VOCs were also detected, but at much lower concentrations. 1,1,1-TCA was noted to be the most elevated contaminant and, therefore, was utilized during the initial evaluation to determine if vapor treatment may be required. The 1,1-dichloroethane (1,1-DCA) and trichloroethylene (TCE) concentrations were also assessed due to their low DAR-1 AGCs. The calculated impacts for the compounds of concern were found to be less than their respective AGCs and SGCs. Therefore, based on the pilot test emissions results, SVE emissions treatment was deemed to be unlikely.

To confirm SVE emissions compliance following the installation of the system, FPM performed effluent sampling of the SVE system on June 26 and October 9, 2008. During each sampling event an effluent sample was collected from the effluent sampling port located between the blower and the effluent stack pipe utilizing a Tedlar air sampling bag. The June 26, 2008 effluent sample was collected while AS-1 was operating. The October 9, 2008 effluent sample was collected while AS-2 was operating. System operation parameters for each event are noted in the previously-shown Table 2.2.1.1. The samples were transported via overnight courier to a New York State Department of Health-approved laboratory for analysis of VOCs by EPA Method T0-14. Table 2.2.2.1 summarizes the laboratory data and the complete laboratory analytical reports are included in Appendix D. The analytical data from the pilot test are included for comparison.

The effluent data indicate that concentrations of several VOCs were detected, but the concentrations of the key VOCs (1,1,1-TCA, PCE, 1,1-DCA and TCE) were all lower than the concentrations detected during the pilot test. Specifically, the primary VOCs detected in the effluent during the pilot test 1,1,1-TCA, chloroethane, and PCE, were all below the concentrations detected during the pilot test. The other parameters necessary to calculate the mass loading rate and the anticipated impacts were also reviewed. The actual SVE flow rate ranges from 320 to 335 SCFM, which is lower than the flow rate used in the pilot test emissions evaluation (450 SCFM). The stack height is 20 feet, which is somewhat less than the 25 feet used in the pilot test evaluation, and the stack's location is somewhat different.

Therefore, to confirm that the SVE system effluent does not need treatment under actual operating conditions, the DAR-1 Appendix B calculations were performed for TCE, which is the VOC that most closely approached its AGC during the pilot test. These calculations are shown on Table 2.2.2.2 and demonstrate that the TCE emissions are well below the AGC and SGC for TCE. Therefore, no effluent treatment measures are necessary at this time. FPM will continue effluent monitoring of the system on a quarterly basis to ensure compliance.

**TABLE 2.2.2.1
SVE EFFLUENT VOLATILE ORGANIC COMPOUND DATA
45 KEAN STREET
WEST BABYLON, NEW YORK**

Sample Name Sample Date	AS Pilot Test	Effluent		SGC in ug/m ³	AGC in ug/m ³
	9/7/2006	6/26/2008	10/9/2008		
AS Flow Rate (scfm)	17	21	23		
SVE Vacuum (inches of water)	8*	32**	33**		
<i>Volatile Organic Compounds in ug/m3</i>					
Benzene	ND	ND	23	1,300	0.13
1,1,1-Trichloroethane	888	189	350	68,000	1,000
1,1-Dichloroethane	61.8	ND	ND	-	0.63
Chloroethane	376	ND	ND	-	10,000
Tetrachloroethene	400	255	110	1,000	1
Toluene	18.8	NA	NA	37,000	5,000
Trichloroethylene	50.8	38.8	12	14,000	0.5
Trichlorofluoromethane	17.1	28.0	80	68,000	1,000

Notes:

Effluent sample on 6/26/08 was collected with AS-1 in operation. Effluent sample on 10/9/08 was collected with AS-2 in operation. Only analytes detected in one or more samples are included in this table. See laboratory reports in Appendix B for complete data.

ND = Not Detected.

NA = Not Analyzed.

SGC = NYSDEC Division of Air Resources Short-Term Guideline Concentration.

AGC = NYSDEC Division of Air Resources Annual Guideline Concentration.

- = Not established.

* = Data recorded during test performed solely on SVE-1.

** = Total SVE flow recorded while operating all three SVE wells.

ug/m3 = micrograms per cubic meter.

**TABLE 2.2.2.2
DAR-1 APPENDIX B CALCULATION FOR TRICHLOROETHYLENE (TCE)**

1. The volume (Equation 1) of one mole of TCE at a maximum effluent temperature of 35 °C (308° K) is:

$$V(L) = \frac{nRT}{P} = \frac{(1.0\text{mol})(0.08331\text{L} \cdot \text{atm} / \text{K} \cdot \text{mol})(308\text{K})}{1.0\text{atm}} = 25.66\text{L}$$

2. The loading rate (Equation 2) given the SVE system maximum total flow rate (Q = 335 scfm from multiple wells) and effluent TCE concentration (C_{max} = 7.1 ppbv) from 6/26/08 effluent data can be calculated using:

$$L(\text{lbs} / \text{hr}) = Q(\text{ft}^3 / \text{min}) \cdot C(\text{ppbv}) \cdot \frac{1}{25.66}(\text{mol} / \text{L}) \cdot 131.4(\text{g} / \text{mol}) \cdot 60(\text{min} / \text{hr}) \cdot 28.32(\text{L} / \text{ft}^3) \cdot$$

$$2.205 \cdot 10^{-3}(\text{lbs} / \text{g}) = 335\text{ft}^3 / \text{min} \cdot 7.1\text{ppbv} \cdot \frac{1}{1 \cdot 10^9} \cdot 19.19(\text{lbs} \cdot \text{min} / \text{hr}) = 4.57 \cdot 10^{-5} \text{ lbs} / \text{hr}$$

II. Cavity Impact Evaluation Procedure

II.A. Basic cavity impact method

h_b = height of building = 20 feet

L = 457 * 10⁻⁵ lbs/hr, (Using Equation 2 with an effluent TCE concentration of 7.1 ppbv and a molecular weight of 131.4 g/mol)

II.A.1.

3h_b = 60 feet

D_{pl} = distance to property line = 5 feet

D_{pl} < 3h_b, therefore, cavity impacts are not confined to onsite receptors. Therefore, calculate cavity impacts.

II.A.2

h_c = building cavity height equals 1.5h_b = 30 feet

h_s = stack height = 20 feet

h_s < h_c, therefore, calculate worst-case cavity impacts.

II.A.3.

Q_a = L (lbs/hr)*24 hrs/day*365 days/yr = 0.40 lbs/yr

C_c = Worst case annual cavity impact (ug/m³) = $\frac{1.72Q_a}{h_b^2} = 0.002 \text{ ug/m}^3 < \text{AGC (0.5 ug/m}^3)$

II.A.4.

C_{CST} = $\frac{904,000 * L}{h_b^2} = 0.10 \text{ ug/m}^3$

II.C. Cavity impact evaluation method

C_{CST} = 0.10 << SGC (54,000 ug/m³)

III.A. Standard point source method

III.A.1

h_s/h_b = 20/20 = 1.0, stack height to building height ratio for vertical stacks

Ratio is less than 1.5, therefore, assume no plume rise occurs and h_e=h_s

III.A.2

C_a = Maximum actual annual impact = $\frac{6.0 * Q_a}{h_c^{2.25}} = 0.002 \text{ ug/m}^3 < \text{AGC (0.5 ug/m}^3)$ because Q_a is based on continuous operation, C_a=C_p.

III.A.3.

C_p = Maximum annual potential impact = $\frac{52,500 * L}{h_c^{2.25}} = 0.003 \text{ ug/m}^3 < \text{AGC (0.5 ug/m}^3)$

III.A.4 Does not apply

III.A.5

C_{ST} = Maximum short term impact = C_p * 65 = 0.20 ug/m³ << SGC (54,000 ug/m³)

2.3 AS/SVE System Operation, Monitoring and Maintenance Plan

System OM&M is performed by FPM personnel on a quarterly basis to ensure proper system operation and emissions compliance. In addition, routine system operation checks are performed monthly. The following is a summary of tasks performed to maintain the remediation system components and monitor the system operation:

Monthly Tasks:

- Perform system check and service moisture separator if needed;
- Read and record all system airflow rates, pressures, and vacuums; and
- Adjust system vacuum and pressure valves as necessary to ensure optimal system performance.

Quarterly Tasks:

- Collect effluent sample for laboratory analysis by EPA method T0-14 and PID screen to ensure emissions compliance; and
- Evaluate SVE mass removal based on effluent data.

Semi-Annual Tasks:

- Perform groundwater monitoring at select Site monitoring wells in accordance with the groundwater monitoring procedures presented in Section 3 herein.

Remediation system performance and progress will be evaluated on the basis of the SVE system emissions data and the semi-annual groundwater sampling results. This information will be provided in an Annual OM&M Report together with groundwater monitoring reporting, as described in Section 3.3.

Criteria for Termination of AS/SVE System:

AS/SVE system performance will be evaluated based on the mass removal rates calculated from the SVE emissions data and based on the anticipated improvement in groundwater quality as the system operates. Termination of the AS/SVE system will be proposed when:

- The mass removal rate becomes low and asymptotic, indicating that the system has reached the limit of its effectiveness; or

- Groundwater conditions improve in the Site-related plume such that the NYSDEC Standards are achieved or are reasonably anticipated to be reached.

Potential termination of the AS/SVE system will be discussed in the annual OM&M Report.

SECTION 3.0 GROUNDWATER MONITORING

A summary of the existing groundwater conditions and the proposed groundwater monitoring procedures are documented in this section. A site plan showing the groundwater monitoring well locations and historic monitoring data is presented on Figure 3.1.

3.1 Summary of Existing Groundwater Conditions

Chlorinated solvent VOCs, including 1,1,1-TCA, 1,1-DCA, chloroethane, and other VOCs, were determined to be present in onsite groundwater. These VOCs appear to be associated with a former drywell on the east side of the site, DW-1, which has been remediated and closed. Groundwater data from onsite water table monitoring wells (FN-1 through FN-4) and from onsite and offsite multi-depth monitoring wells (ML-1 through ML-3) were previously provided to the NYSDEC in an October 5, 2005 groundwater monitoring report. Total chlorinated VOCs in each well in August 2005 are shown on Figure 3.1; in the case of the multi-level wells, the total chlorinated VOCs at each sampling depth are shown. The site-specific groundwater flow direction (south-southeast) determined in February 2007 is also shown on this figure.

These data show that chlorinated solvent VOCs were present in groundwater in close proximity to the former DW-1 structure (well FN-3) and in shallow onsite groundwater downgradient of this structure (well ML-2 at 20 feet) at concentrations exceeding the NYSDEC Class GA Ambient Water Quality Standards (Standards). One chlorinated solvent VOC was also detected in shallow groundwater at the onsite ML-1 location; however, the detected concentration (1 ug/l of 1,1,1-TCA) is below the NYSDEC Standard. Chlorinated solvent VOC-impacted groundwater was not found further upgradient of the former DW-1 structure at the FN-1 or FN-2 locations nor at the nearby onsite FN-4 location. Based on these data, the onsite chlorinated VOC groundwater plume appeared to be limited to the eastern edge of the Site in proximity to the former DW-1 location.

Offsite groundwater data are available only at well ML-3, which is located crossgradient of the anticipated track of the plume from 45 Kean Street. None of the site-related chlorinated VOCs were detected in any of the shallow intervals of this well. However, several chlorinated VOCs were noted in the interval at 80 feet below grade. The primary VOC detected was tetrachloroethene (PCE), which was not found in any of the onsite wells with the exception of a low estimated concentration (1.2 J) in well FN-3. Chloroform, bromodichloromethane, and dibromochloromethane were also found in the ML-3 samples and were not noted in any of the onsite samples from 45 Kean Street. Based on this information, it was determined that multi-level well ML-3 is not intersecting the plume from 45 Kean

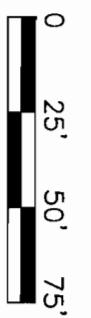
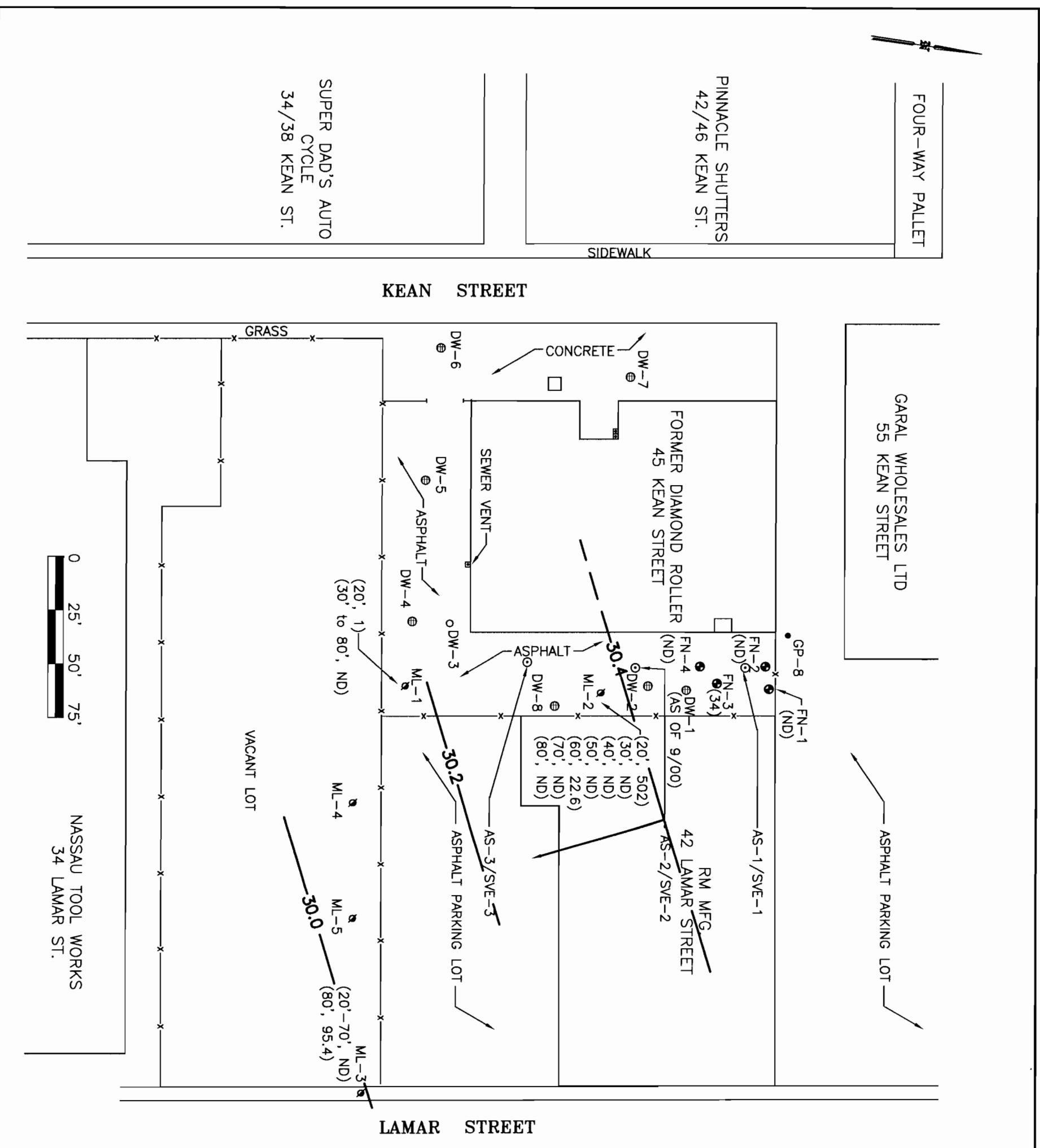

- LEGEND:**
- — MONITORING WELL LOCATION
 - — MULTI LEVEL MONITORING WELL LOCATION
 - ⊖ — OPEN-GRATE DRYWELL LOCATION
 - — OVERFLOW DRYWELL
 - — DIRECT-PUSH GROUNDWATER LOCATION
 - (22.6) — TOTAL CHLORINATED VOCs IN MICROGRAMS PER LITER, AUGUST 2005 WITH SAMPLE DEPTH, IF AVAILABLE
 - (ND) — NOT DETECTED
 - 30.4— — GROUNDWATER RELATIVE ELEVATIONS, FEBRUARY 2007
 - — GROUNDWATER FLOW DIRECTION

FPM GROUP

FIGURE 3.1
 SITE PLAN WITH TOTAL CHLORINATED
 VOCs IN GROUNDWATER, AUGUST 2005
 45 KEAN STREET
 NORTH BABYLON, NEW YORK

Drawn By: J.S. H.C. Checked By: J.B. Date: 11/14/08

Street, but is most likely sampling the plume from an upgradient source (possibly Pride Solvents, #152025). In addition, existing multi-level data indicates that the plume associated with the site is present only in the shallow groundwater and that deeper impacts appear to be associated with an upgradient source.

Based on the historic onsite and offsite groundwater data, two additional offsite multi-level groundwater monitoring wells (ML-4 and ML-5) were installed downgradient of the plume. The installation of these wells was proposed in our January 22, 2007 letter to the NYSDEC and approved by the NYSDEC on February 21, 2007. Details of the well installations are described below.

3.2 Offsite Groundwater Monitoring Well Installation

Two offsite downgradient multi-level groundwater monitoring well clusters (ML-4 and ML-5) were installed in the undeveloped lot to the south of the Site. The boreholes for each well cluster were drilled with a hollow-stem auger rig; the cuttings were logged based on visual characteristics and were screened with a calibrated photoionization detector (PID). A boring log was prepared for each location to document the materials encountered. Copies of the boring logs are included in Appendix A. Soils at each location consisted of fine-to-medium grained sand with gravel and trace silt. No indications of impacts were observed, and no organic vapors were detected by the PID.

Each multi-level well cluster was constructed using three one-inch diameter Schedule 40 PVC well casings with a five-foot slotted screen centered on each targeted sampling depth: 20, 30 and 40 feet below grade. Morie #2 filter pack sand was placed between one foot below and one foot above each screen interval, and bentonite grout placed between the sand pack intervals using a tremie pipe. A well construction diagram for each well cluster is included on the corresponding boring log in Appendix A. After installation each well was developed to remove fines.

3.3 Groundwater Monitoring and Reporting Plan

Groundwater monitoring will be performed for the two newly-installed offsite well clusters and select onsite monitoring wells for the purpose of defining the current extent and nature of the site groundwater plume. The proposed monitoring locations are as follows: FN-2, FN-3, FN-4, ML-1 at 20, 30 and 40 feet, ML-2 at 20, 30 and 40 feet, and all intervals of ML-4 and ML-5. These selected wells and intervals may be modified in the future based on the monitoring results. Any proposed changes in the groundwater program will be requested in the periodic groundwater monitoring reports, as described below.

3.3.1 Groundwater Monitoring Procedures

At each well to be sampled, the depth to water will be measured with a water level indicator and recorded to the nearest 0.01 foot. A minimum of three casing volumes of water will be then be purged from each well using either a decontaminated submersible pump with dedicated polyethylene tubing, or dedicated polyethylene tubing with a check valve attached. All non-disposable equipment that enters the well will be decontaminated with a low-phosphate detergent and potable water wash followed by a distilled water rinse prior to use.

Following the removal of each casing volume, field parameters, including pH, turbidity, specific conductivity, and temperature will be monitored. Stability will be considered achieved when all stability parameters vary less than 10 percent between the removal of successive casing volumes and after at least three casing volumes have been removed. Upon achievement of stability, a water sample will be obtained from each well using a dedicated disposable bailer.

Samples will be placed into laboratory-provided sample containers. Each sample container will be labeled with the location, well number, date and time of sampling, and analysis to be performed. The labeled sample containers will then placed in laboratory-supplied coolers with ice to depress the temperature. A chain-of-custody form will be filled out and kept with the samples in the coolers to document the sequence of sample possession. The sample coolers will be delivered by an overnight courier to the selected laboratory, TestAmerica Laboratories, Inc. of Connecticut. The groundwater samples will be analyzed for TCL VOCs using EPA SW846 Method 8260B, and reporting will include Category B deliverables. QA/QC protocols will be as described in Section 4.0.

3.3.2 Groundwater Monitoring Reporting

Groundwater monitoring will be reported on an annual basis in conjunction with AS/SVE OM&M reporting. It is anticipated that the annual OM&M Report will be submitted during the first quarter following the end of each calendar year.

3.3.3 Criteria for Termination of Groundwater Monitoring

It is anticipated that groundwater monitoring will be performed during the first quarter and in the third quarter of each calendar year until the AS/SVE system is shut down in accordance with the criteria in Section 2.3 herein. Following system shutdown, FPM will perform groundwater monitoring on two additional occasions; between 3 and 6 months and again between 9 and 12 months following shutdown. If, after the additional monitoring, no significant increase in downgradient groundwater VOC concentrations is noted relative to the VOC concentrations at system shutdown, then a request for a

termination of the AS/SVE system and groundwater monitoring and closure of this VCP Site will be made.

SECTION 4.0

QUALITY ASSURANCE/QUALITY CONTROL PROCEDURES

Quality assurance/quality control (QA/QC) protocols include several types of procedures to assure the quality of the analytical data collected. The QA/QC procedures to be utilized during groundwater monitoring activities at the Site are described in the following sections.

4.1 Sampling Equipment Decontamination Procedures

All non-disposable equipment (i.e., water level indicator and pump) used during the groundwater purging activities will be decontaminated by washing in a potable water and Alconox solution and rinsing in potable water prior to use at each location to reduce the potential for cross contamination. The decontamination procedures utilized for all non-disposable equipment sampling equipment will be as follows:

1. The equipment will be scrubbed in a bath of potable water and low-phosphate detergent followed by a potable water rinse;
2. The equipment will be rinsed with distilled water; and
3. The equipment will be allowed to air dry, if feasible, and wrapped in aluminum foil (shiny side out) for storage and transportation.

4.2 Chain-of-Custody Procedures

For each day of sampling, a chain-of-custody form will be completed and submitted to the laboratory. A copy of the chain-of-custody form will also be retained by FPM for sample tracking purposes. The chain-of-custody form will include the project name, the sampler's signature, the types and sizes of sample bottles and preservatives used, the sampling locations, intervals, and the analytical parameters and methods requested.

4.3 QA/QC Samples

Several types of QA/QC samples will be obtained during the groundwater sampling. The results will be utilized to evaluate the accuracy and precision of the laboratory data.

An equipment blank sample will be collected to evaluate the effectiveness of decontamination procedures. The sample will consist of an aliquot of laboratory-supplied water poured over the dedicated or decontaminated sampling equipment and then submitted to the laboratory for analysis.

A trip blank sample will be collected to evaluate the potential for VOC cross-contamination between samples in the same cooler. The trip blank sample will consist of an aliquot of laboratory

water sealed in sample bottles at the laboratory and transported to the field with the empty sample bottles, and returned to the laboratory for analysis in the same cooler as the primary samples.

A duplicate groundwater sample will be collected to attest to the precision of the laboratory. The duplicate sample will consist of a separate aliquot of sample collected at the same time, in the same manner, and analyzed for the same parameters as the primary environmental samples.

Matrix spike/matrix spike duplicate (MS/MSD) groundwater samples will be collected to confirm the accuracy and precision of laboratory results based on a particular matrix.

SECTION 5.0 REMEDIAL ACTION OBJECTIVES

As discussed in Section 1.5.1 of the RAWP (Fenley & Nicol Environmental, Inc., December 2003), several remedial action objectives (RAOs) have been established for this Site. The remedial measures, as currently implemented, have been evaluated with respect to their potential for achieving the RAOs, as discussed below. Anticipated achievement of each of the RAOs is evaluated as follows:

- **Reduce VOC contamination in onsite groundwater to a reasonable level.**

The AS/SVE system, as designed and installed, is anticipated to reduce or eliminate impacts to onsite groundwater. Groundwater monitoring will be performed at select onsite monitoring wells as discussed in Section 3.3 herein. The results from this monitoring will be used to assess the effectiveness of the AS/SVE system towards achieving this RAO.

- **Eliminate or reduce, to the extent practicable, offsite migration of contaminants in groundwater.**

Operation of the AS/SVE system is designed to reduce or eliminate the potential for offsite contamination migration; therefore, this RAO should be achieved as the system operates. Offsite groundwater monitoring will be performed at select offsite wells as outlined in Section 3.3 so that the anticipated reductions in offsite migration of impacted groundwater may be assessed and the achievement of the RAO may be documented.

SECTION 6.0 REFERENCES

Fenley & Nicol Environmental, Inc., June 2005. *Revised Voluntary Cleanup Agreement Remedial Action Work Plan for 45 Kean Street West Babylon, New York*

FPM Group, February 2007. *Pilot Test Report for 45 Kean Street, West Babylon, New York*

New York State Department of Environmental Conservation, September 10, 2007, July 12, 2000, November 12, 1997, and September 10, 2007. *DAR-1*.

New York State Department of Environmental Conservation, March 8, 1998. *Water Quality Regulations for Surface Waters and Groundwaters*.

APPENDIX A

- **AS AND SVE WELL INSTALLATION LOGS**
- **ML-4 AND ML-5 BORING LOGS**

FPM GROUP

Ronkonkoma, New York

SITE MAP

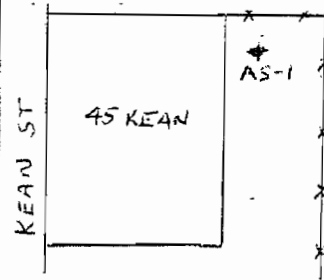

FPM PROJECT # GYSIN FPM JOB # 891-06-01
 SITE ADDRESS 45 KEAN ST
 BORING/WELL AS-1 TOTAL DEPTH 33 ft DIAMETER 4 1/4"
 TOC ELEV. _____ WATER LEVEL INITIAL ~15 ft STATIC _____
 SCREEN DIA. 2 in LENGTH 2 ft SLOT SIZE 0.020 in
 CASING DIA. 2 in LENGTH 30 ft TYPE Sch. 40
 DRILLING COMP. LAWES DRILLING METHOD Hollow Stem Auger
 DRILLER E. Santiago LOG BY JB DATE DRILLED 7/19/06

DEPTH (FEET)	SAMPLE	OVA/PID (ppm)	WELL CONSTRUCTION	GRAPHIC LOG	DESCRIPTION/SOIL CLASSIFICATION (INTERVAL, RECOVERY, COLOR, MATRIX TYPE, MOISTURE CONTENT, COMMENTS)
2					0'-5' Grey-brown sand and gravel, Dry No odors.
4					
6		0.0	sand		5'-15' Light brown fine to coarse sand with trace gravel. No odors, Dry to moist.
8					
10					15'-33' Light brown fine to medium sand with trace gravel, Wet, No odors.
12		0.3		SP	
14			Bentonite grout		
16					
18		0.5			
20					
22					
24					
26		0.4			
28					
30			WELL GRAVEL		
32					
34					
36					
38					
40					
42					
44					
46					
48					
50					
52					

FPM GROUP
Ronkonkoma, New York

SITE MAP

FPM PROJECT # GYSIN FPM JOB # 891-06-01
 SITE ADDRESS 45 KEAN ST
 BORING/WELL AS-2 TOTAL DEPTH 33 ft DIAMETER 4 1/4"
 TOC ELEV. _____ WATER LEVEL INITIAL ~15 ft STATIC _____
 SCREEN DIA. 2 in LENGTH 2 ft SLOT SIZE 0.020 in
 CASING DIA. 2 in LENGTH 30 ft TYPE Sch. 40
 DRILLING COMP. LAWES DRILLING METHOD Hollow Stem Auger
 DRILLER E. Santiago LOG BY JB DATE DRILLED 7/19/00

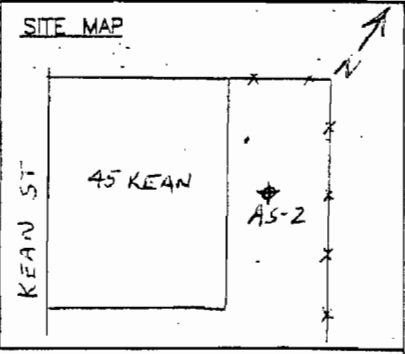

DEPTH (FEET)	SAMPLE	OVA/PID (ppm)	WELL CONSTRUCTION	GRAPHIC LOG	DESCRIPTION/SOIL CLASSIFICATION (INTERVAL, RECOVERY, COLOR, MATRIX TYPE, MOISTURE CONTENT, COMMENTS)
2					0'-5' Grey-brown sand and gravel, Dry No odors.
4					
6		0.0	sand		5'-15' Light brown fine to coarse sand with trace gravel. No odors. Dry to moist.
8					
10			Bentonite grout	SP	15'-33' Light brown fine to medium sand with trace gravel. Wet. No odors.
12		0.8			
14					
16					
18		0.5			
20					
22					
24					
26		0.8			
28					
30			WELL GRAVEL		
32					
34					
36					
38					
40					
42					
44					
46					
48					
50					
52					

FPM GROUP

Ronkonkoma, New York

SITE MAP

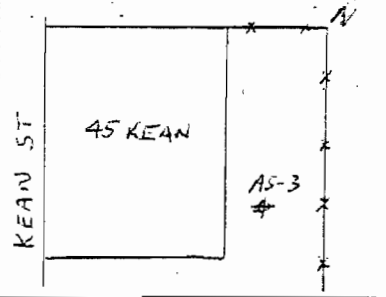

FPM PROJECT # GYSIN FPM JOB # 891-06-01
 SITE ADDRESS 45 KEAN ST
 BORING/WELL AS-3 TOTAL DEPTH 33 ft DIAMETER 4 1/4"
 TOC ELEV. _____ WATER LEVEL INITIAL ~15 ft STATIC _____
 SCREEN DIA. 2 in LENGTH 2 ft SLOT SIZE 0.020 in
 CASING DIA. 2 in LENGTH 30 ft TYPE Sch. 40
 DRILLING COMP. LAWES DRILLING METHOD Hollow Stem Auger
 DRILLER E. Santrage LOG BY JB DATE DRILLED 7/29/04

DEPTH (FEET)	SAMPLE	OVA/PID (ppm)	WELL CONSTRUCTION	GRAPHIC LOG	DESCRIPTION/SOIL CLASSIFICATION (INTERVAL, RECOVERY, COLOR, MATRIX TYPE, MOISTURE CONTENT, COMMENTS)
2					0'-5' Grey-brown sand and gravel, Dry No odors.
4					
6		0.0	sand		
8					5'-15' Light brown fine to coarse sand with trace gravel. No odors. Dry to moist.
10					
12		0.5			
14				SP	15'-33' Light brown fine to medium sand with trace gravel. Wet. No odors.
16					
18		0.6	Bentonite grout		
20					
22					
24					
26		0.8			
28					
30			WELL GRAVEL		
32					
34					
36					
38					
40					
42					
44					
46					
48					
50					
52					

FPM GROUP
Ronkonkoma, New York

SITE MAP

FPM PROJECT # GYSIN FPM JOB # 891-06-01
 SITE ADDRESS 45 KEAN ST
 BORING/WELL SVE-1 TOTAL DEPTH 15 ft DIAMETER 4 1/4 in
 TOC ELEV. _____ WATER LEVEL INITIAL ~15 ft STATIC _____
 SCREEN DIA. 2 in LENGTH 6 ft SLOT SIZE 0.020 in
 CASING DIA. 2 in LENGTH 8 ft TYPE Sch. 40
 DRILLING COMP. LAWES DRILLING METHOD Hollow Stem Auger
 DRILLER E. Santiago LOG BY JB DATE DRILLED 7/19/06

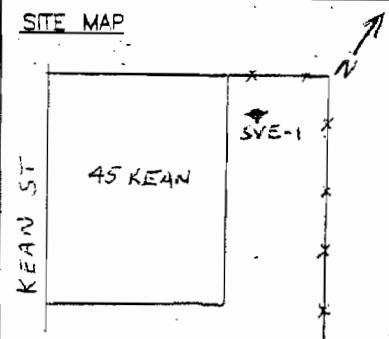

DEPTH (FEET)	SAMPLE	OVA/PID (ppm)	WELL CONSTRUCTION	GRAPHIC LOG	DESCRIPTION/SOIL CLASSIFICATION (INTERVAL, RECOVERY, COLOR, MATRIX TYPE, MOISTURE CONTENT, COMMENTS)
2		0.0		SP	0'-5' Grey-light brown fine to coarse sand and gravel. No odors. Dry
4		0.0			5'-15' Light brown fine to medium sand with trace gravel. Wet at ~15'. No odors.
6					
8		0.0			
10					
12					
14		0.8			
16					
18					
20					
22					
24					
26					
28					
30					
32					
34					
36					
38					
40					
42					
44					
46					
48					
50					
52					

FPM GROUP

Ronkonkoma, New York

SITE MAP

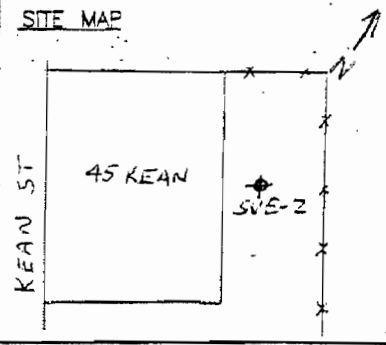

FPM PROJECT # GYSIN FPM JOB # 891-06-01
 SITE ADDRESS 45 KEAN ST
 BORING/WELL SVE-2 TOTAL DEPTH 15 ft DIAMETER 4 1/4 in
 TOC ELEV. _____ WATER LEVEL INITIAL ~15 ft STATIC _____
 SCREEN DIA. 2 in LENGTH 6 ft SLOT SIZE 0.020 in
 CASING DIA. 2 in LENGTH 8 ft TYPE Sch. 40
 DRILLING COMP. LAWES DRILLING METHOD Hollow Stem Auger
 DRILLER E. Santrage LOG BY JB DATE DRILLED 7/29/06

DEPTH (FEET)	SAMPLE	OVA/PID (ppm)	WELL CONSTRUCTION	GRAPHIC LOG	DESCRIPTION/SOIL CLASSIFICATION (INTERVAL, RECOVERY, COLOR, MATRIX TYPE, MOISTURE CONTENT, COMMENTS)
2		0.0	Sand		0'-5' Grey-light brown fine to coarse sand and gravel. No odors. Dry
4			Bent. Gravel		
6				SP	5'-15' Light brown fine to medium sand with trace gravel. Wet at ~15'. No odors.
8		0.0			
10			Well Gravel		
12					
14		0.0			
16					
18					
20					
22					
24					
26					
28					
30					
32					
34					
36					
38					
40					
42					
44					
46					
48					
50					
52					

FPM GROUP
 Ronkonkoma, New York

SITE MAP

FPM PROJECT # GYSIN FPM JOB # 891-06-01
 SITE ADDRESS 45 KEAN ST
 BORING/WELL SVE-3 TOTAL DEPTH 15 ft DIAMETER 4 1/4 in
 TOC ELEV. _____ WATER LEVEL INITIAL ~15 ft STATIC _____
 SCREEN DIA. 2 in LENGTH 6 ft SLOT SIZE 0.020 in
 CASING DIA. 2 in LENGTH 8 ft TYPE Sch. 40
 DRILLING COMP. LAWES DRILLING METHOD Hollow Stem Auger
 DRILLER E. Satriage LOG BY JB DATE DRILLED 7/19/06

KEAN ST

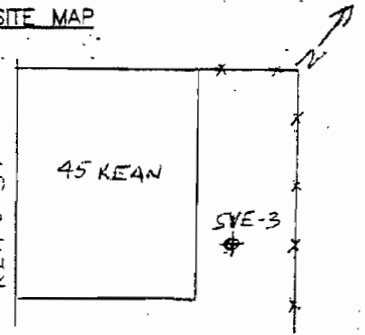

DEPTH (FEET)	SAMPLE	OVA/PID (ppm)	WELL CONSTRUCTION	GRAPHIC LOG	DESCRIPTION/SOIL CLASSIFICATION (INTERVAL, RECOVERY, COLOR, MATRIX TYPE, MOISTURE CONTENT, COMMENTS)
2		0.0		SP	0'-5' Grey-light brown fine to coarse sand and gravel. No odors. Dry
4		0.0			5'-15' Light brown fine to medium sand with trace gravel. Wet at ~15'. No odors.
6		0.4			
8					
10					
12					
14					
16					
18					
20					
22					
24					
26					
28					
30					
32					
34					
36					
38					
40					
42					
44					
46					
48					
50					
52					

FPM GROUP
 Ronkonkoma, New York

SITE MAP

FPM PROJECT # 45 KEAN ST FPM JOB # 891-06-01
 SITE ADDRESS WEST BABYLON, NY
 BORING/WELL ML-4 TOTAL DEPTH 43' DIAMETER 8.5 in
 TOC ELEV. _____ WATER LEVEL INITIAL ~20' STATIC _____
 SCREEN DIA. 1 in LENGTH see below SLOT SIZE .010
 CASING DIA. 1 in LENGTH see below TYPE Sch. 40
 DRILLING COMP. F&N DRILLING METHOD Hollow Stem Auger
 DRILLER LM LOG BY LB DATE DRILLED 6/21/07

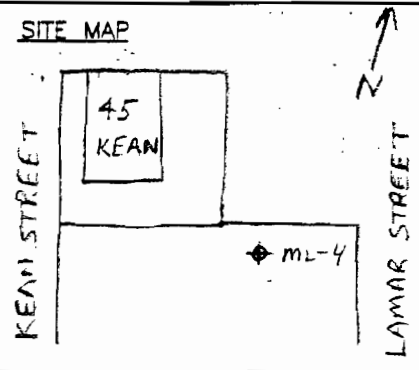

DEPTH (FEET)	SAMPLE	OVA/PID (ppm)	WELL CONSTRUCTION	GRAPHIC LOG	DESCRIPTION/SOIL CLASSIFICATION (INTERVAL, RECOVERY, COLOR, MATRIX TYPE, MOISTURE CONTENT, COMMENTS)
2	NA				<p>Light brown fine to medium sand with gravel. No odors or staining noted. Wet at approximately 17' b.g.</p> <p>NOTE: No samples collected. Drill cuttings continually evaluated during well installation.</p>
4					
6					
8					
10					
12					
14					
16					
18		0.0	BENTONITE	SP	
20			SAND		
22					
24			BENT.		
26					
28			SAND		
30					
32					
34			BENT		
36					
38			SAND		
40					
42					
44					
46					
48					
50					
52					

FPM GROUP

Ronkonkoma, New York

SITE MAP

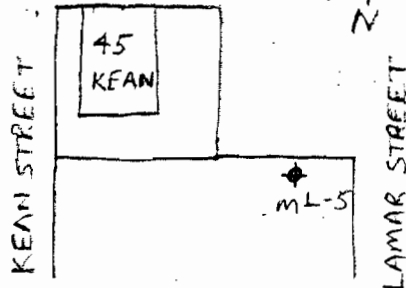

FPM PROJECT # 45 KEAM ST FPM JOB # 891-06-01
 SITE ADDRESS WEST BABYLON, NY
 BORING/WELL ML-5 TOTAL DEPTH 43' DIAMETER 8.5 in
 TOC ELEV. _____ WATER LEVEL INITIAL ~20' STATIC _____
 SCREEN DIA. 1 in LENGTH see below SLOT SIZE .010
 CASING DIA. 1 in LENGTH see below TYPE Sch. 40
 DRILLING COMP. F&N DRILLING METHOD Hollow Stem Auger
 DRILLER JM LOG BY JB DATE DRILLED 6/21/07

DEPTH (FEET)	SAMPLE	OVA/PID (ppm)	WELL CONSTRUCTION	GRAPHIC LOG	DESCRIPTION/SOIL CLASSIFICATION (INTERVAL, RECOVERY, COLOR, MATRIX TYPE, MOISTURE CONTENT, COMMENTS)
2	NA	0.0	BENTONITE	SP	Light brown fine to medium sand with gravel. No staining or odors. Wet at ~17' b.g.
4					
6					
8					
10					
12					
14					
16					
18					
20					
22					
24					
26					
28					
30					
32					
34			BENT		NOTE: No samples collected. Drill cuttings continually evaluated during well installation.
36					
38					
40					
42					
44					
46					
48					
50					
52					

APPENDIX B

SYSTEM PROCESS INSTRUMENTATION DIAGRAMS

SYSTEM LAYOUT

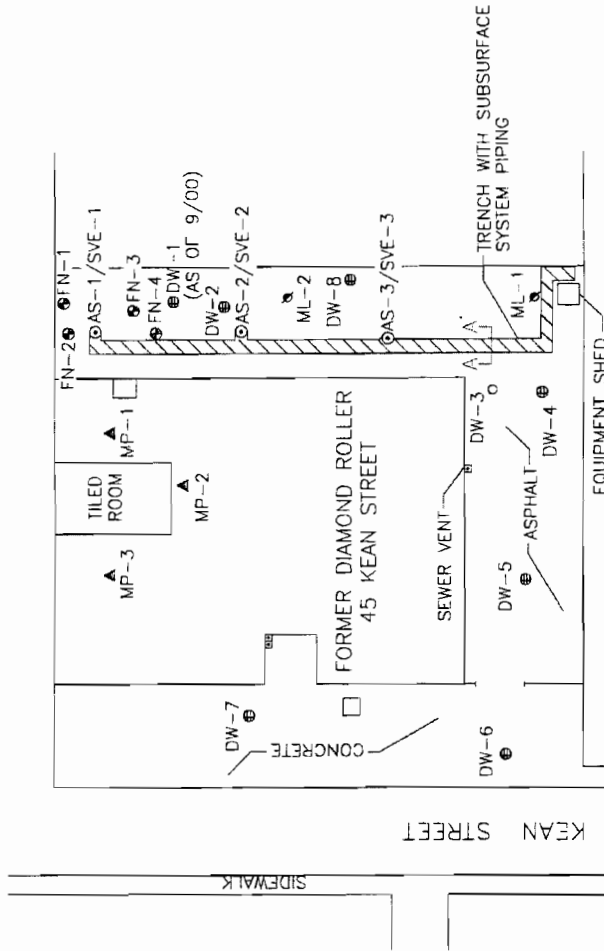

APPROXIMATE SCALE IN FEET:



LEGEND:

- FN-1 — MONITORING WELL LOCATION
- MP-1 — MULTI LEVEL MONITORING WELL LOCATION
- DW-1 — OPEN-GRATE DRYWELL LOCATION
- ML-1 — OVERFLOW DRYWELL
- AS-1/SVE-1 — CO-LOCATED AS AND SVE WELLS
- MP-1 — SUB-SLAB MONITORING POINT
- A A' — TRENCH CROSS-SECTION

TRENCH CROSS-SECTION

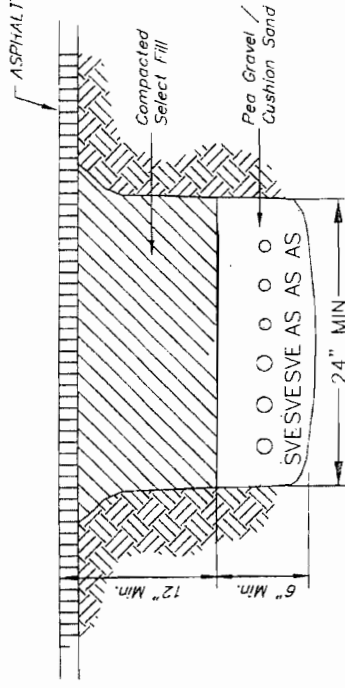

SECTION A-A'

LEGEND:

- O = 3" Ø SCH 80 PVC
- SVE = SVE PIPING
- O = 1 1/2" Ø SCH 80 CPVC
- AS = AS PIPING

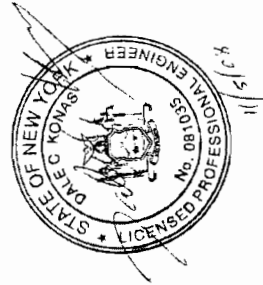

DRAWN/REVISED BY: JW	FIGURE: 1
REVISION DATE: OCTOBER 31, 2008	
DRAWING TITLE AS-BUILT AS/SVE SYSTEM PIPING LAYOUT	
PROJECT NAME 45 KEAN STREET WEST BABYLON, NEW YORK	
PREPARED FOR FPM GROUP 909 MARCONI AVENUE RONKONKOMA, NEW YORK 11779	
 FPM GROUP 909 MARCONI AVENUE RONKONKOMA, NEW YORK 11779 5 OLD DOCK ROAD, YAPHANK, NEW YORK 11960 PHONE: (631)924-5001 FAX: (631)924-5001	

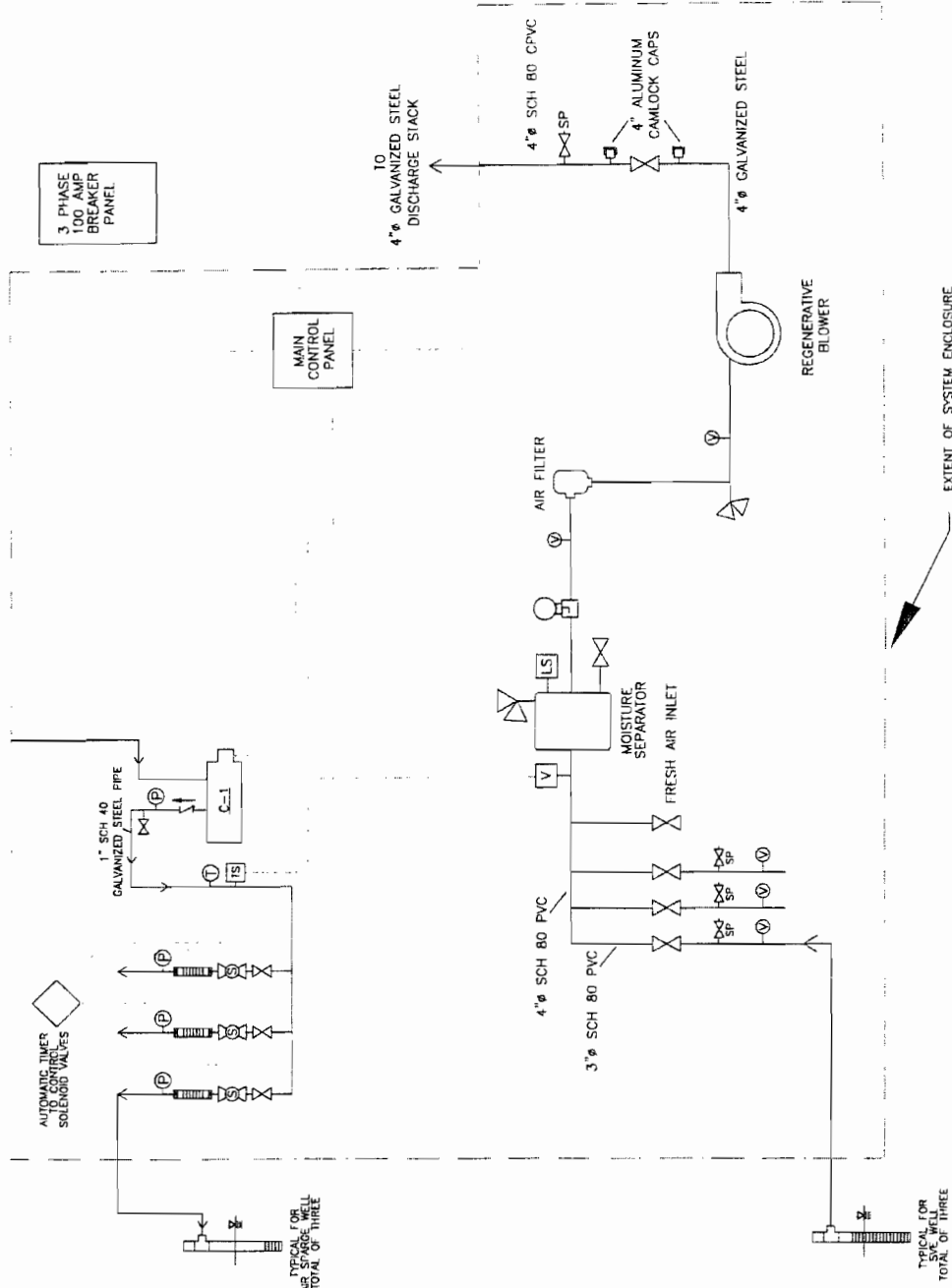

- SYSTEM LEGEND:**
- ⊕ VACUUM GAUGE
 - ⊖ TEMPERATURE GAUGE
 - ⊙ PRESSURE GAUGE
 - ⊗ SAMPLE PORT
 - ⊘ BALL VALVE
 - ⊙ VENTURI FLOWMETER
 - ⊖ ROTAMETER FLOWMETER
 - ⊙ VACUUM RELIEF VALVE
 - ⊗ CHECK VALVE
 - ⊙ SOLENOID VALVE
 - ⊖ LEVEL SWITCH
 - ⊙ TEMPERATURE SWITCH
 - ⊖ VACUUM SWITCH
 - ⊖ ELECTRIC LINE
 - ⊖ AIR FLOW DIRECTION
 - ⊖ ENCLOSURE LIMITS

DRAWN/REVISED BY: JW
 REVISION DATE: OCT 27, 2008
FIGURE: 2

DRAWING TITLE
 AS-BUILT AIR SPARGE/SOIL VAPOR
 EXTRACTION SYSTEM PROCESS AND
 INSTRUMENTATION DIAGRAM

PROJECT NAME
 45 KEAN STREET
 WEST BABYLON, NEW YORK

PREPARED FOR
 FPM GROUP
 909 MARCONI AVENUE
 RONKONKOMA, NY 11779

EMCOR
 ENGINEERING & CONSULTING
 5 OLD DUCK ROAD, VAPHANK, NEW YORK 11860
 PHONE: (631)924-3001 FAX: (631)924-8001



EXTENT OF SYSTEM ENCLOSURE
 NON HAZARDOUS LOCATION

NOTES:
 BLOWER: SIEMENS MODEL NO: 2BH1830-7AH16 (8.5 HP, 3 PH, TEFC)
 COMPRESSOR: BECKER MODEL NO: KD13.60 (5 HP, 3 PH, TEFC)

3. PHASE
 100 AMP
 BREAKER
 PANEL

MAIN
 CONTROL
 PANEL

TO
 4" GALVANIZED STEEL
 DISCHARGE STACK

4" SCH 80 CFVC
 4" ALUMINUM
 CAMLOCK CAPS

4" GALVANIZED STEEL

REGENERATIVE
 BLOWER

AIR FILTER

MOISTURE
 SEPARATOR

FRESH AIR INLET

1" SCH 40
 GALVANIZED STEEL PIPE

C-1

AUTOMATIC TIMER
 TO CONTROL
 SOLENOID VALVES

TYPICAL FOR
 AIR SPARGE WELL
 TOTAL OF THREE

TYPICAL FOR
 SW. WELLS
 TOTAL OF THREE



DRAWN/REVISED BY: JW	FIGURE: 3
REVISION DATE: OCT 27, 2008	
DRAWING TITLE	AS-BUILT AS/SVE SYSTEM ENCLOSURE LAYOUT
PROJECT NAME	45 KEAN STREET WEST BABYLON, NEW YORK
PREPARED FOR	FPM GROUP 909 MARCONI AVENUE RONKONKOMA, NEW YORK 11779

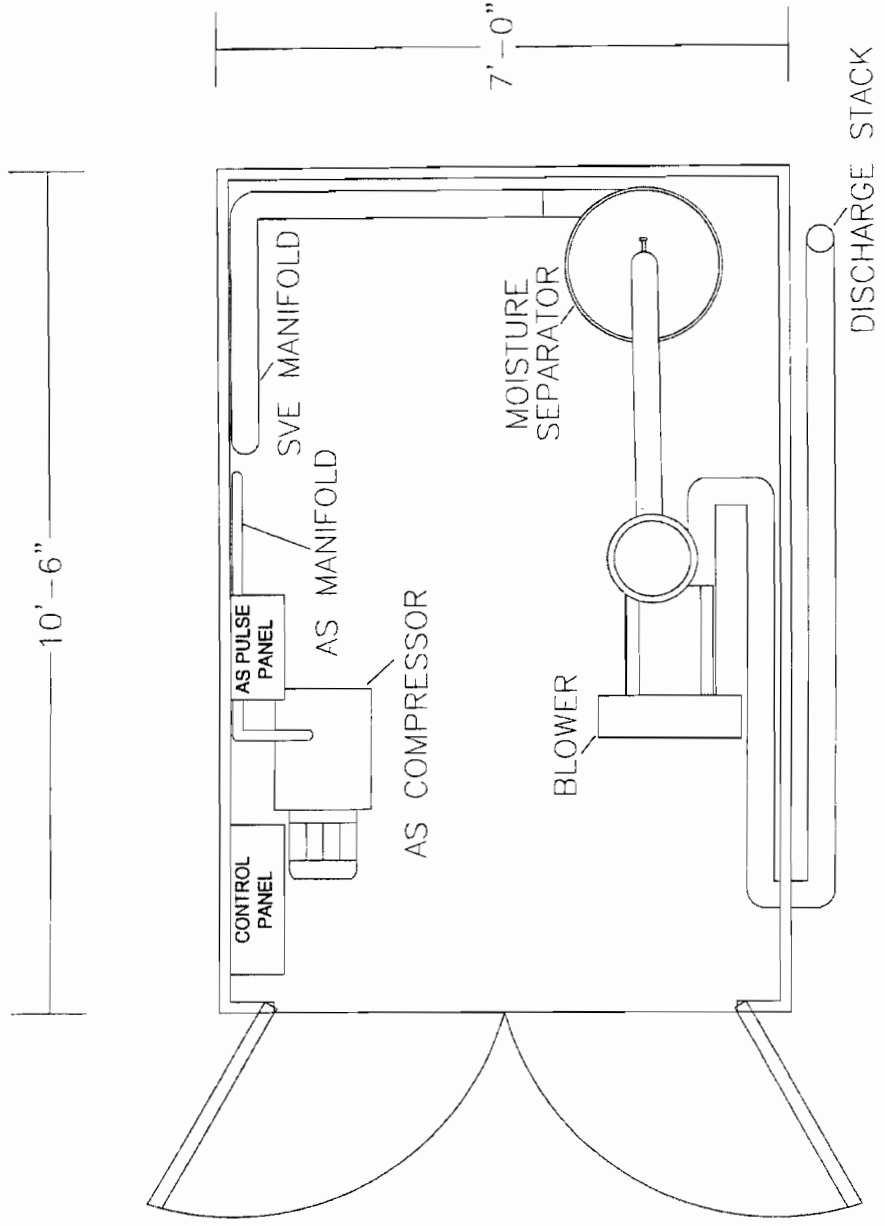

DRAWING LEGEND

- NORMALLY OPEN SWITCH
- COIL OF MOTOR CONTACTOR "X"
- GREEN LIGHT
- RED LIGHT
- NORMALLY CLOSED CIRCUIT
- NORMALLY OPEN CIRCUIT
- THERMAL OVERLOAD
- TERMINAL BLOCK
- PLC/Ox PLC DISCRETE OUTPUT x
- PLC/Ix PLC DISCRETE INPUT x

SVE BLOWER
NASH-FILMO 2BH1830
8.5 hp, 3-PHASE, 208-230/460 VAC, 60 Hz

AIR-SPARGE COMPRESSOR
BECKER KDT 3.60
5 hp, 3-PHASE, 208-230/460 VAC, 60 Hz

REVISION # 1.2
DRAWN/REVISED BY: OL
REVISION DATE: 06-24-2008

DRAWING TITLE
AS-BUILT SYSTEM SCHEMATIC
SVE/AS CONTROL PANEL
ETNY S/N: FPM-45KEAN-W.BAB

PROJECT NAME
45 KEAN STREET
WEST BABYLON, NEW YORK

PREPARED FOR
FPM GROUP
909 MARCONI AVENUE
RONKONKOMA, NY 11779

FIGURE: 4

5 OLD DOCK ROAD, YAPHANK, NEW YORK 11987
PHONE (631)247-3001 FAX (631)247-5001

POWER DISTRIBUTION

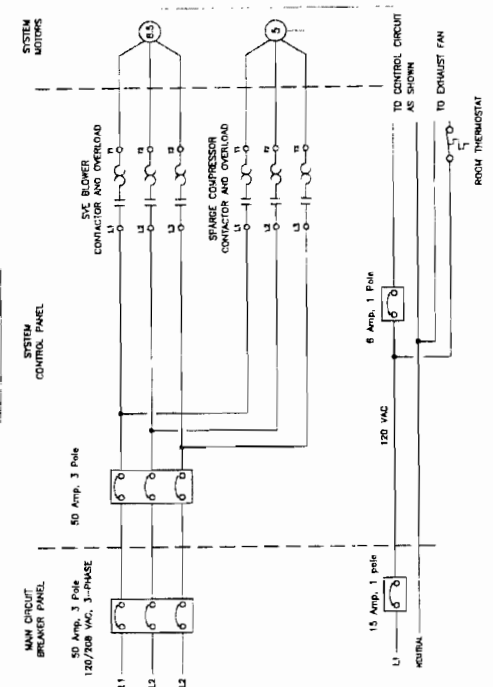

SENSOR/PLC WIRING DETAIL

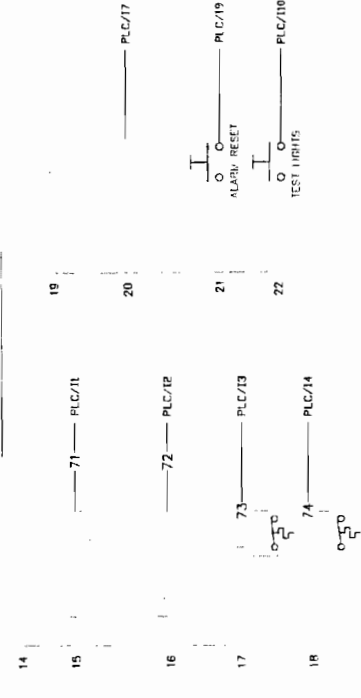

CONTROL CIRCUIT LADDER SCHEMATIC

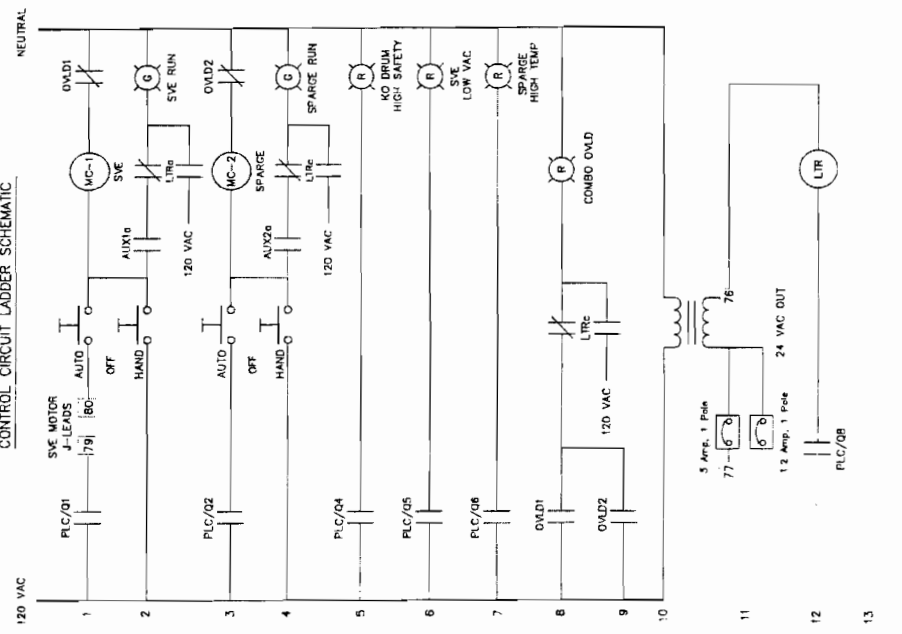

TERMINAL BLOCK LAYOUT & DESIGNATIONS

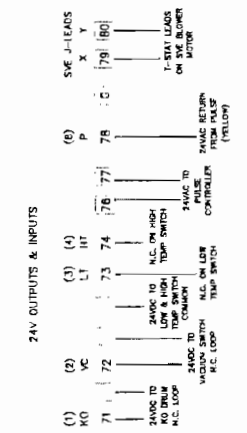

BASIC PLC LAYOUT & I/O DESIGNATIONS

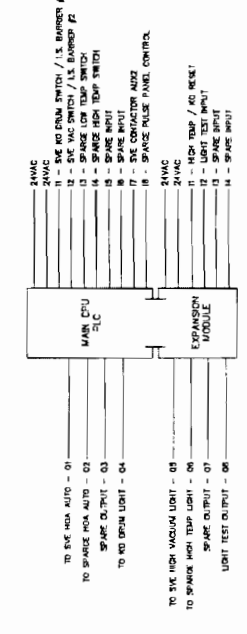

APPENDIX C
EQUIPMENT SPECIFICATIONS

KDT Series

ISO 9001 Certified
 CE Compliant

100% OIL-LESS COMPRESSORS

The Becker KDT series is a line of 100% Oil-less, rotary vane, low pressure compressors. They are designed to operate on a continuous basis throughout a pressure range from atmospheric pressure to 22 PSIG.

Each KDT unit is a direct drive compressor and is supplied with a TEFC flange mounted electric motor. Each unit is equipped with inlet and discharge filters, a pressure regulating valve, and vibration isolators as

standard equipment, all of which are an integral part of the compressor.

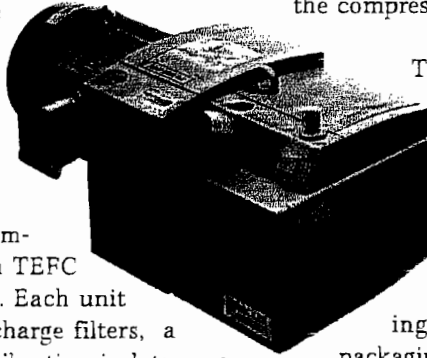

The Becker KDT compressor is ideal for applications where air is the gas and where operation is in the low pressure range where high pressure compressors are less efficient. Applications for the KDT compressor include graphic arts, soil remediation, pneumatic conveying, robotics and material handling, packaging, and paper converting.

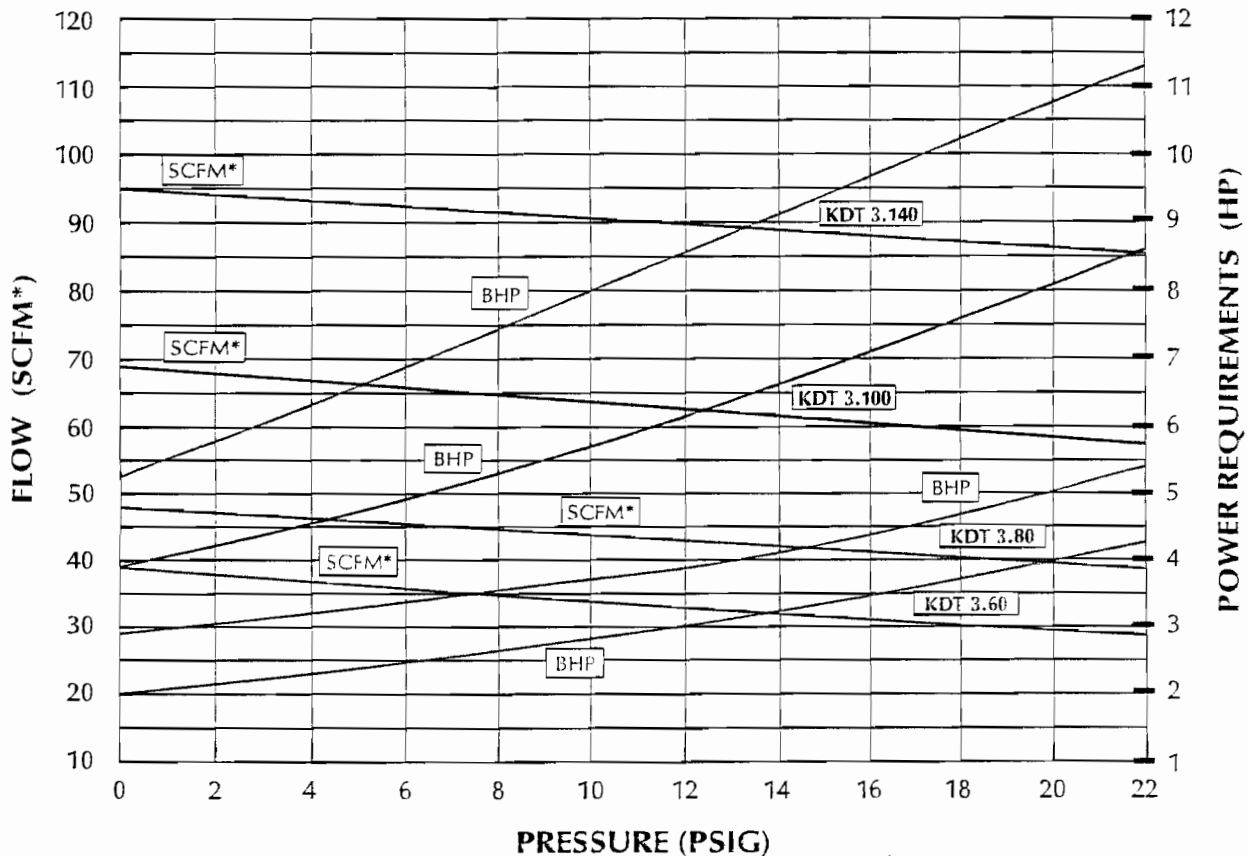

* @ 29.92" Hg Bar. Pr.: 68°F; 36% R.H.; 0.075#/ft³

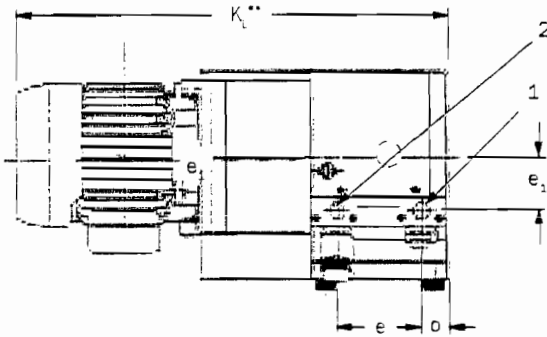
TECHNICAL DATA

Top View

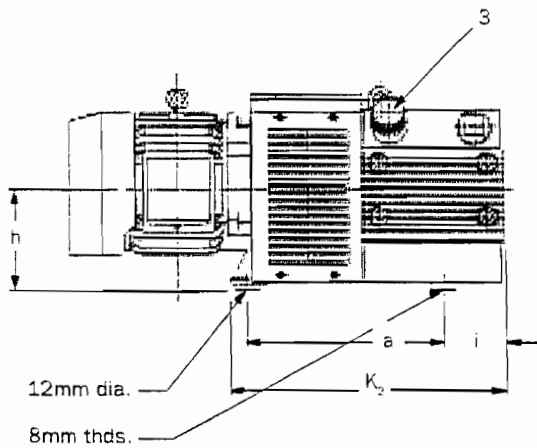

Side View

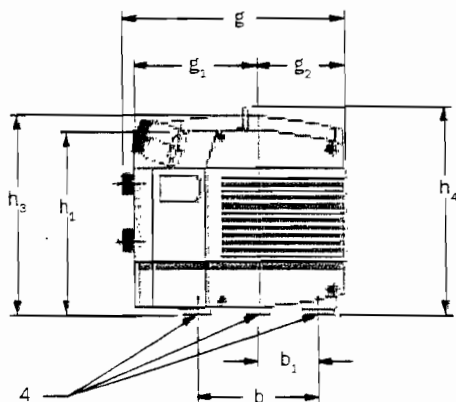

End View (Opposite Motor End)

All data based on 60 Hz operation

	KDT 3.60	KDT 3.80	KDT 3.100	KDT 3.140
Flow (SCFM @ 0 PSIG)	39	48	69	95
Horsepower	5*	7 1/2*	10*	12*
Speed (RPM)	1740	1740	1740	1740
Maximum Pressure (PSIG)	22	22	22	22
Weight (lbs.)—w/o motor	104	108	156	172
Weight (lbs.)—w/ motor**	191*	265*	323*	368*
Noise Level (Max. dBA)	74	76	78	84
Outlet size (BSP, inches)	1	1	1 1/2	1 1/2
Dimensional Data	(Inches)			
a	12.83	12.83	15.67	15.67
b	7.5	7.5	9.65	9.65
b ₁	3.75	3.75	4.82	4.82
e	5.43	5.43	7.5	7.5
e ₁	2.56	2.56	3.75	3.75
g	13.9	13.9	18.5	18.5
g ₁	7.68	7.68	8.78	8.78
g ₂	5.55	5.55	9.06	9.06
h	6.38	6.38	6.38	6.38
h ₁	11.38	11.38	11.7	11.7
h ₃	12.28	12.28	13.0	13.0
h ₄	12.9	12.9	13.25	13.25
i	3.78	3.78	5.5	5.5
k ₂	17.64	17.64	22.17	22.17
k _L	28.2	30	34.15	36.6
o	1.81	1.81	2.36	2.36

Manufacturer reserves right to alter data without notice.

* Operation at lower pressure may use smaller motor.

** May vary with motor type and manufacturer

- 1 - Inlet Port
- 2 - Discharge Port
- 3 - Pressure Relief Valve
- 4 - Vibration Isolators

3LTTD006 • 2/00

Becker Pumps Corp. • 100 East Ascot Lane • Cuyahoga Falls, Ohio 44223-3768

Ph. (330) 928-9966 • (888) 633-1083 • FAX: (330) 928-7065 • info@beckerpumps.com • www.beckerpumps.com

2BH1 830

Performance curve for Vacuum pump

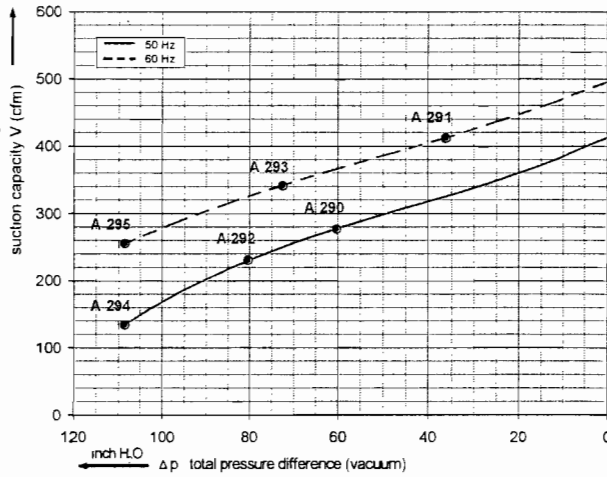

Performance curve for Compressor

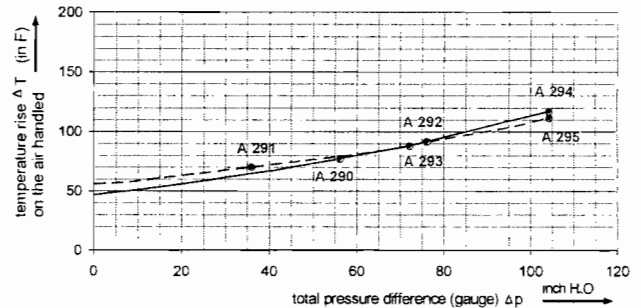
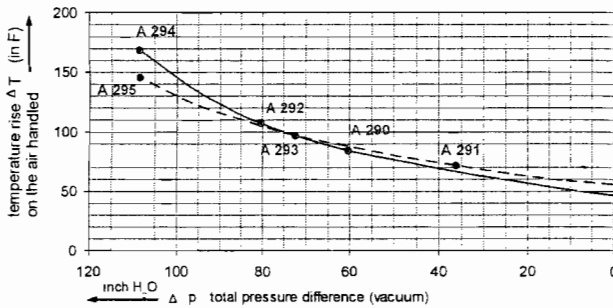
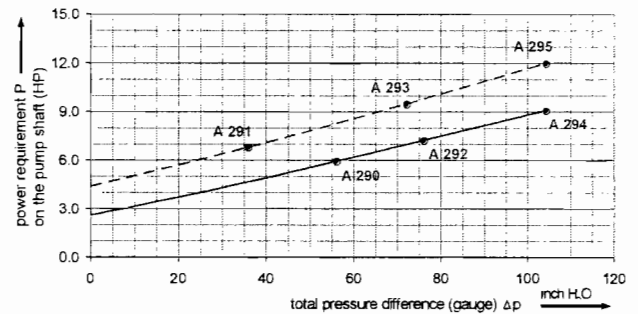
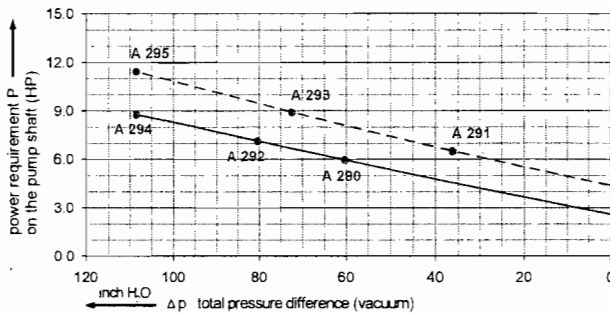
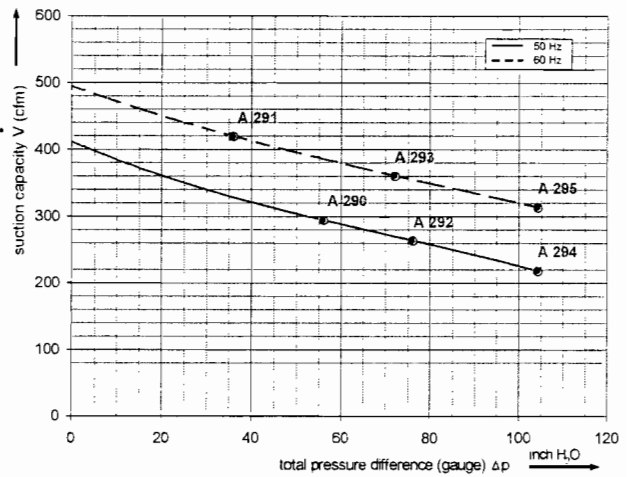

The performance curves are based on air at a temperature of 59 F and an atmospheric pressure of 401.53 inch H₂O with a tolerance of +/- 10 %. The total pressure differences are valid for suction and ambient temperatures up to 77 °F. For other conditions please confer with us.

Each G_200 type can be applied both as vacuum pump and compressor in continuous operation over the total stated performance curve range. The motors are available as standard for the input voltage range of 50 and 60 Hz and for protection category IP 55 as well as approved for UL and CSA. Blowers with ATEX 94/9 EG are available, too.

Selection and ordering data

Type 2BH1 830

Curve No	Order No.	Fre- quency	Rated power	Input voltage		Input current		Permissible total differential pressure ²⁾		Sound pressure level ³⁾	Weight ca.
				Hz	HP	V	A	Vacuum inch H2O	Compressor inch H2O		
3~ 50/60 Hz IP55 isulation material class F 1)											
A 290	2BH1830-7AH06	50	5.36	200D ... 240D	345Y ... 415Y	16.4D	9.5Y	-60	56	70	247
A 291	2BH1830-7AH06	60	6.17	220D ... 275D	380Y ... 480Y	16.4D	9.5Y	-36	36	74	247
A 292	2BH1830-7AH16	50	7.37	200D ... 240D	345Y ... 415Y	23.0D	13.3Y	-80	76	70	278
A 293	2BH1830-7AH16	60	8.45	220D ... 275D	380Y ... 480Y	23.0D	13.3Y	-72	72	74	278
A 294	2BH1830-7AH26	50	10.05	200D ... 240D	345Y ... 415Y	29.0D	16.7Y	-108	104	70	282
A 295	2BH1830-7AH26	60	11.53	220D ... 275D	380Y ... 480Y	30.0D	17.3Y	-108	104	74	282
3~ 50/60 Hz IP55 isulation material class F 1)											
A 290	2BH1830-7AC05	50	5.36	500D		7.5D		-60	56	70	247
A 291	2BH1830-7AC05	60	6.17	575D		7.6D		-36	36	74	247
A 292	2BH1830-7AC15	50	7.37	500D		10.5D		-80	76	70	278
A 293	2BH1830-7AC15	60	8.45	575D		10.4D		-72	72	74	278
A 294	2BH1830-7AC25	50	10.05	500D		13.0D		-108	104	70	282
A 295	2BH1830-7AC25	60	11.53	575D		13.6D		-108	104	74	282

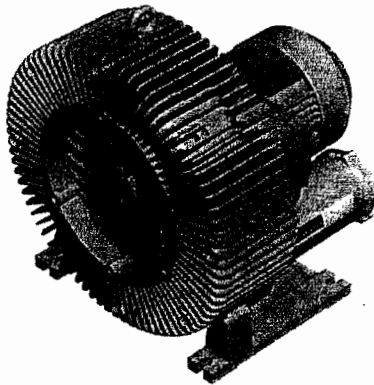

Other voltage ranges		
2BH1830-7A <input type="checkbox"/> <input type="checkbox"/>		
50Hz	60Hz	↑ ↑
3~		
185...225 V D / 320...390 V Y	200...240 V D / 345...415 V Y	H 1
200...240 V D / 345...415 V Y	220...275 V D / 380...480 V Y	H 6
345...415 V D	380...480 V D	H 7
500 V D	575 V D	C 5

Machines according to the ATEX norm 94/4 EG are available for the whole performance range

Following types available: Category 3 G, 3/2 G, 3 D and 3/2 D

Further voltage range on request; please quote in plain text.

All G_200 achieve the standards and norms of the low voltage directive 72/23/EWG, rotating electrotechnical motor EN 60034-1-34, electromag-netic compatibility (EMC) DIN EN 61000-3-6/-4.

- 1) For standard UL for ELECTRIC FANS UL 507 and CSA 22.2 No. 13 for Fans and Ventilators (Certificate Number E225239).
- 2) Relief-valve are available for limiting differential pressure.
- 3) Measuring-surface sound-pressure level acc. to DIN EN 21680, measured at a distance of 3.28 ft. The pump is throttled to an average suction pressure, a hose is connected to the discharge side (vacuum pump) / suction side (compressor), but is not fitted with relief valves.

The motors are designed according to the DIN EN 60 034 / DIN IEC 34-1 and temperature class F.

For the three phase machines the tolerances are +/- 10 % for fixed voltage and +/- 5 % for voltage range.

For all three phase machines which designed according to the UL and CSA norm (UL 507 and CSA 22.2 No. 100) the maximum allowed voltage tolerances are - 10 % resp. + 6 %.

The frequency tolerance is maximum +/- 2 %.

Changes in particular the quoted performance curve, datas and weights without prior notice. The figures are without obligations.

www.nash-elmo.com

nash_elmo Industries, LLC

2 Trefoil Drive
Trumbull 0661, CT
USA

info@nash-elmo.com

nash_elmo Industries GmbH

Katzwanger Str. 150
90461 Nürnberg
Germany

+49 911 1454 - 0

nash_elmo Industries GmbH

Industriestr. 26
97616 Bad Neustadt/Saale
Germany

Filtration Accessories

Blower Connection Key

NPT – American National Standard Taper Pipe Thread (Male)

NPSC – American National Standard Straight Pipe Thread for Coupling (Female)

SO – Slip On (Smooth – No Threads)

Moisture Separator™

- By separating and containing entrained liquids, Rotron's moisture separator helps protect our regenerative blowers and the end treatment system from corrosion and mineralization damage. Recommended for all soil vacuum extraction applications.

SPECIFICATIONS:

SEPARATION METHOD – High Efficiency Cyclonic

RELIEF VALVE MATERIAL – Brass & Stainless Steel

FLOAT MATERIAL – Copper

FLOAT SWITCH – SPDT, Explosion-proof
NEMA 7&9, 5 Amp max.

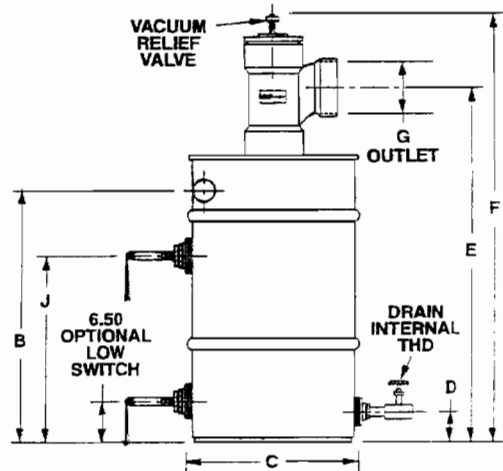
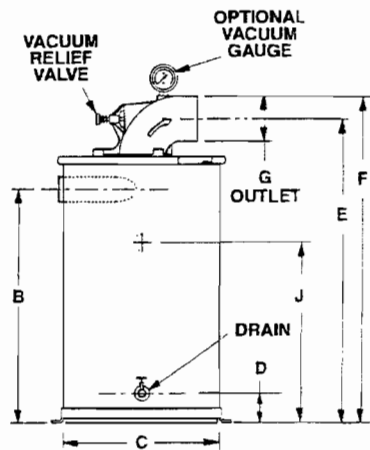
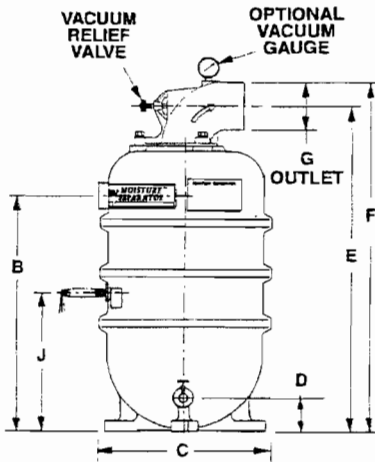
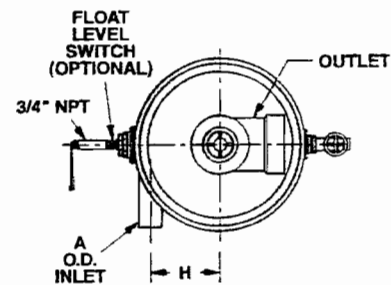
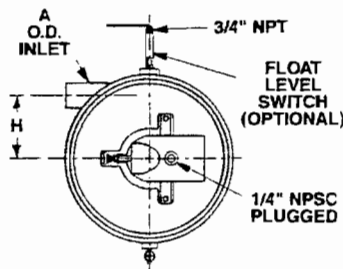
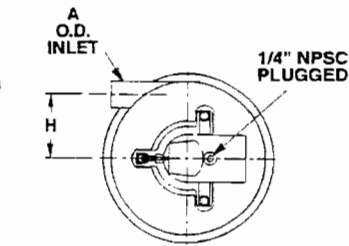

PLASTIC "P" DESIGN

METAL "D" DESIGN

METAL "B" DESIGN

Model	Part No.	CFM Max.	A Dia.	B	C Dia.	D	E	F	G Dia.	H	J Switch	Drain Internal THD	Shipping Weight
MS200PS	038519	200	2.38	22.46	16.00	3.25	31.05	33.30	4.50 OD	6.00	13.25	3/4" NPT	42 lb.
MS300PS	038520	300	2.88										
MS200DS	080086	200	2.00	22.12	16.75	2.75	27.92	30.17		6.56	12.62		
MS300DS	080087	300	2.50										
MS350BS	038357	350	3.25	28.00	23.00	4.00	37.25	39.50	6.63 ID	9.75	17.50	1" NPT	82 lb.
MS500BS	080660	500											96 lb.
MS600BS	080659	600											4.00
MS1000BS	038914	1000	6.00	31.00	27.00		47.32	51.70	8.62 OD	10.00	19.88		150 lb.

Models without float switch available. Metal MS200/300DS models are not the standard stocked, but are available.

Rev. 2/04

Blower Model Reference Key	
A = SPIRAL	E = DR/EN/CP 656, 6, 623, S7
B = DR/EN/CP 068, 083, 101, 202	F = DR/EN/CP 707, 808, 858, S9, P9 (Inlet Only)
C = DR/EN/CP 303, 312, 313, 353	G = DR/EN/CP 823, S13, P13 (Inlet Only)
D = DR/EN/CP 404, 454, 513, 505, 555, 523	H = DR/EN/CP 909, 979, 1223, 14, S15, P15 (Inlet Only)

2.0 Moisture Separator™ Specifications

2.1 DUTY

The moisture separator shall be designed for use in a soil vapor extraction system capable of continuous operation with a pressure drop of less than six inches of water at the rated flow of _____ SCFM. The separator shall be capable of operation under various inlet conditions ranging from a fine mist to slugs of water with high efficiency.

2.2 PRINCIPLE OF OPERATION

The moisture separator shall incorporate cyclonic separation to remove entrained water. The separator must protect against an overflow by fail safe mechanical means. An electrical switch or contact(s) alone is not an acceptable means of protection against overflow, but is a good backup.

2.3 CONSTRUCTION

The body of the moisture separator shall be constructed of heavy wall plastic or heavy gauge cold rolled steel. The steel interior and exterior shall be epoxy (powder) coated to resist abrasion, corrosion, and chipping that might expose the surface. The inlet shall be tangentially located and welded to the body. The outlet port shall be constructed of PVC or cast aluminum alloy, flanged and sealed to the center of the top of the separator. The separator shall incorporate a non-sparking copper

float ball and an adjustable relief valve to protect against overflow and overheating the blower.

2.4 CAPACITY AND DIMENSIONS

The moisture separator must have a liquid capacity of _____ gallons. The inlet shall be _____ inch OD slip-on type. The outlet shall be _____ inch OD slip-on type.

For DR/EN/CP Blower Model	Selector Moisture Separator Model	Liquid-holding Capacity (gallons)	Inlet (OD)	Outlet	Max Vacuum Allowed (IHg)
404 454 505 513 523 555 623 823	MS200PS	7	2.38	4.5" OD	12
	MS200DS	10	2.0		22
656 6 707	MS300PS	7	2.88	6.63" ID	12
	MS300DS	10	2.5		22
808	MS350BS				
858 1223	MS500BS	40	3.25	6.63" ID	22
909	MS600BS		4.0"		
979 14	MS1000BS	65	6.0"	8.62" OD	

2.5 PRESSURE DROP

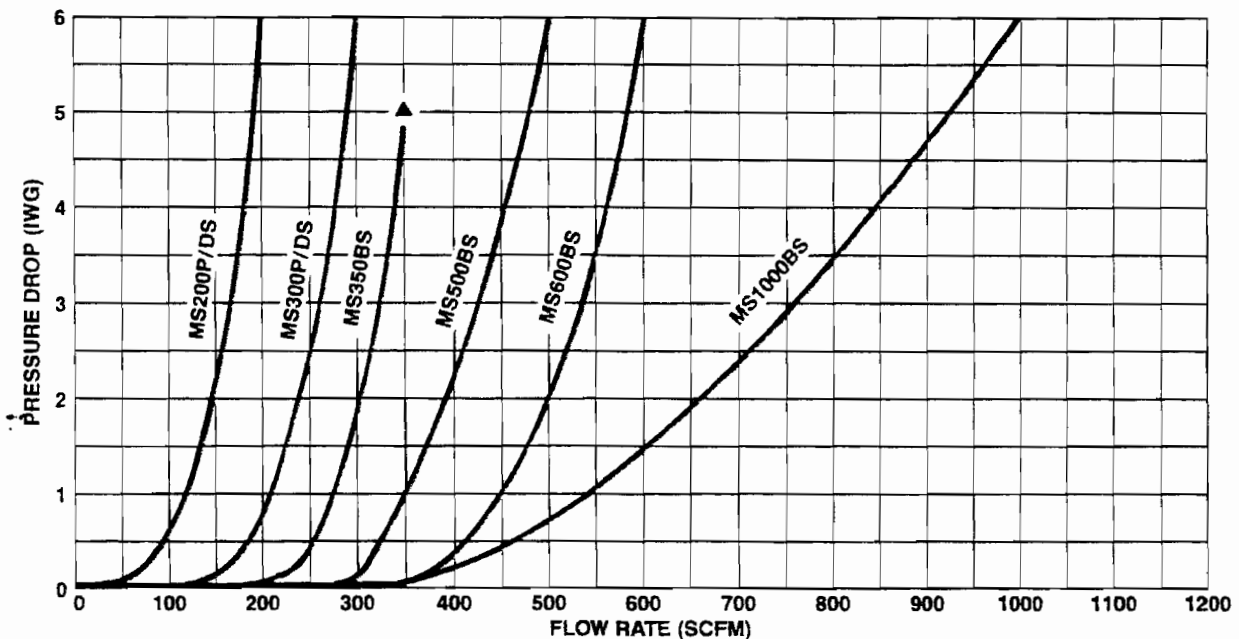



"L" STYLE INLET VACUUM AIR FILTERS "CSL" Series 3" - 6" MPT

APPLICATIONS

- Ash Handling
- Bag House Systems
- Blowers Fan
- Blowers-PD Type
- Cement
- Chemical Processing
- Envelope Manufacturing
- Factory Automation
- Food Processing-Vacuum
- Glass, Ceramic-Vacuum
- Intake Suction-Vacuum Pump
- Medical
- Pneumatic Conveying Systems
- Remote Installations for Piston and Screw Compressors
- Vacuum Furnaces
- Vacuum Packaging
- Vacuum Pump-Rotary Vane
- Vacuum Pumps & Systems
- Vacuum Pump-Screw Technology
- Vacuum Pump-Side Channel
- Vacuum Systems-Central
- Waste Water Aeration
- Woodworking

FEATURES & SPECIFICATIONS

- 99%+ removal efficiency std: Paper=2 micron, Polyester=5 micron
- Filter change out differential: 10"-15" in. H₂O above initial delta P
- Heavy duty T bolts for easy maintenance
- Hydrostatically tested 0.5 bar pressure for vacuum tightness
- Inlet air enters canister above element
- Inlet/Outlet 1/4" gauge taps standard
- Large dirt holding capacity and easy field cleaning
- Low pressure drop
- Positive sealing O-ring seal system
- Powder coat paint finish
- Rugged all steel construction with baked enamel finish
- Temp (continuous): min -15° F (-26° C) max 220° F (104° C)
- Vacuum level: Typically 1x10⁻³ mmHg (1.3x10⁻³ mbar)

OPTIONS

- Activated carbon prefilter to reduce odor
- Available in *Stainless Steel*
- Epoxy coated housings
- Larger sizes available
- Special connections, BSPT/Metric
- Support brackets
- Various elements available

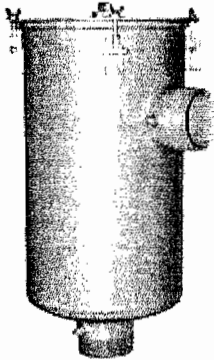

Click to see larger image.

Line Drawing

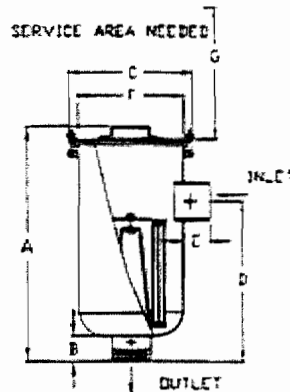

*All measurements are shown in standards.

Typical Lead Times:

- 1 - 2 weeks
- 3 - 4 weeks

- Normally in stock
- 5 - 7 weeks
- 8 + weeks

Add To Order	Model Number	Element Type	Inlet in. NPT or FLG	Outlet in. NPT or FLG	Connection Style	Dim A in.	Dim B in.	Dim C in.	Dim D in.	Dim E in.	Dim F in.	Dim G in.	Parent Flow SCFM	Element Parent Flow SCFM	Approx. Weight lbs.	CAD
<input type="checkbox"/>	CSL-235P-400	Polyester	4	4	Call	27.12	3	14	18.5	3	12	10	520	570	52	<input type="checkbox"/>

Solberg Mfg.

1151 W. Ardmore Ave. Itasca, IL 60143 (630)773-1363 Fax: (630)773-0727

ZONE	REV	DESCRIPTION	REVISIONS	ECN #	CHG BY	DATE	APP'D
1							
2							

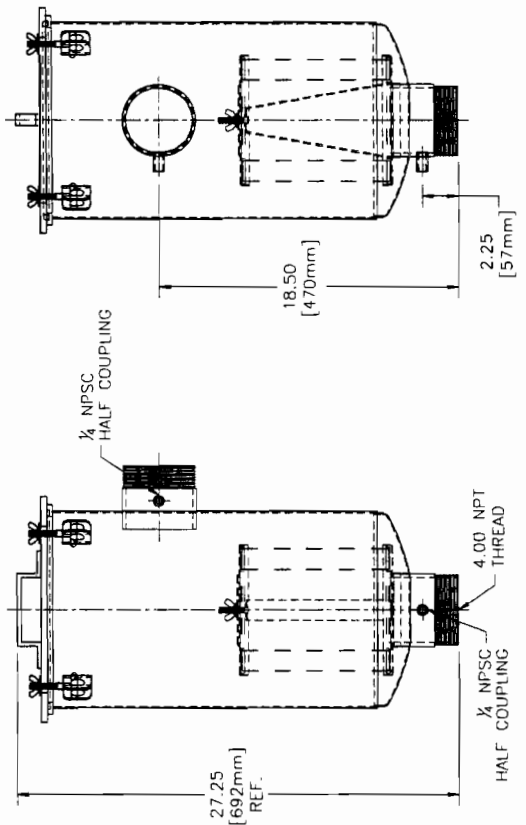
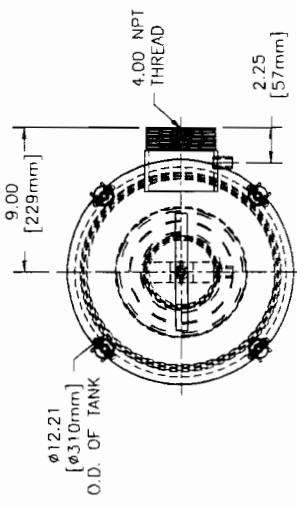

REPLACEMENT ELEMENT # 235P	
MATERIAL	POLYESTER
CFM FLOW	570
SURFACE AREA	8.3 SQ. FT.
I.D.	4.75
O.D.	7.88
HEIGHT	9.63

MODEL #	HOUSING MATERIAL	FINISH
CSL-235P-400	CARBON STEEL	BAKED ENAMEL GREY



SOLBERG MANUFACTURING INC.
1151 W. ARDMORE AVE.
BLOOMINGTON, IL 61710-1443

DESCRIPTION:
CSL-235P-400

SHEET #	OF	SHEET	SCALE
1	1	C	1:5.5

DATE	BY	REV
09/07/05	DMW	
09/07/05	DMW	
09/07/05	DMW	

UNLESS OTHERWISE SPECIFIED:
-DIMENSIONS ARE IN INCHES UNLESS OTHERWISE SPECIFIED.
-TOLERANCES ARE:
DECIMALS .XX ±.025
FRACTIONS 1/16 ±.015
ANGLES .5° ±.05°
CUSTOMER APPROVAL

ZONE	REV	DESCRIPTION	REVISIONS	ECN #	CHG BY	DATE	APP'D
1							
2							

Select A 200 Series Model Number

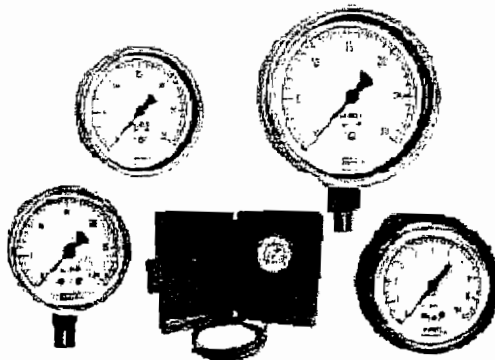

GENERAL INFORMATION

NOSHOK 200 Series Diaphragm Gauges are designed for extremely low pressure or vacuum measurement. The ultra sensitive diaphragm capsules are rated for pressure (or vacuum) as low as 0-10 **inches of water** and as high as 0-10 **psi**.

The cases are constructed of black painted steel on the 2 1/2" size and 304 Stainless Steel on the 4" size. The lenses are molded plexiglass on the 2 1/2" size and instrument glass on the 4" size for strength and clarity. The diaphragm capsules are phosphor bronze and when coupled to the precision all-brass movements, provide extremely accurate indication over the service life of the gauge.

Available options include a recalibrator on the 2 1/2" size (accessible through the front of the dial) and overpressure protection of up to 200% of the dial range. Mounting options include 304 stainless steel or black steel triangular bezels and U-Clamps in addition to chrome or black steel front flanges.

Applications for **NOSHOK 200 Series Gauges** include medical, biomedical, heating-ventilating and air conditioning, gas distribution, filtration, burner and gas combustion service, waste water treatment and everywhere low pressure and vacuum measurement is required.

Measurement Accessories

Blower Connection Key	
NPT	American National Standard Taper Pipe Thread (Male)
NPSC	American National Standard Straight Pipe Thread for Coupling (Female)
SO	Slip On (Smooth - No Threads)

Air Flow Meter

FEATURES

- Direct reading in SCFM
- Low pressure drop (2-4" typical) across the flow meter
- Non-clogging, low impedance air stream
- Light weight aluminum
- No moving parts
- Large easy-to-read dial
- Accurate within 2% at standard conditions
- Good repeatability
- Available in 2", 3" and 4" sizes
- Factory configured for quick installation
- .048" Allen key supplied for gauge adjustment

OPTIONS

- Corrosion-resistant version with Chem-Tough™ or in stainless steel
- FDA-approved Food Tough™ surface conversion

BENEFITS

- **OPTIMIZE SYSTEM EFFICIENCY**
Measuring the correct air flow can assist you in fine-tuning to your system's optimal efficiency.
- **BALANCE MULTI-PIPING SYSTEMS**
When evacuating CFM from more than one pipe, different run lengths or end system impedance can cause one pipe to handle more CFM than the other. With an accurate CFM reading, piping can be balanced by bleeding air in/out or by creating an extra impedance.
- **DETECT CHANNELING OR PLUGGING**
For systems in which channeling or plugging can occur, a change in the CFM measured can help indicate the unseen changes in your system.

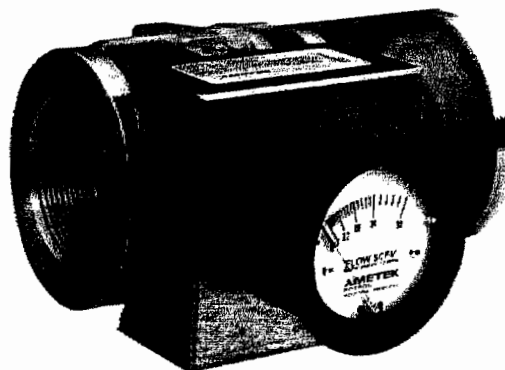

Current Models		Flow Range (SCFM)	B Threads	C Length	D Width	E	F
Model	Part #						
FM20C030Q	550599	6-30	2" - 11.5 NPSC	7.18"	7.0"	2.0"	3.75"
FM20C045Q	550600	9-45					
FM20C065Q	550601	13-65					
FM20C125Q	550602	25-125					
FM20C175Q	550603	35-175					
FM20C225Q	550604	45-225					
FM30C250Q	550605	50-250	3" - 8 NPSC	7.52"	7.4"	2.5"	4.43"
FM30C350Q	550606	70-350					
FM30C475Q	550607	95-475					
FM40C450Q	550608	90-450	4" - 8 NPSC	8.00"	7.7"	2.7"	5.43"
FM40C600Q	550609	120-600					
FM40C850Q	550610	170-850					

ROTRON® Regenerative Blowers

Blower Model Reference Key	
A = SPIRAL	E = DR/EN/CP 656, 6, 623, S7
B = DR/EN/CP 068, 083, 101, 202	F = DR/EN/CP 707, 808, 858, S9, P9 (Inlet Only)
C = DR/EN/CP 303, 312, 313, 353	G = DR/EN/CP 823, S13, P13 (Inlet Only)
D = DR/EN/CP 404, 454, 513, 505, 555, 523	H = DR/EN/CP 909, 979, 1223, 14, S15, P15 (Inlet Only)

Measurement Accessories

TYPICAL FLOW METER ARRANGEMENT

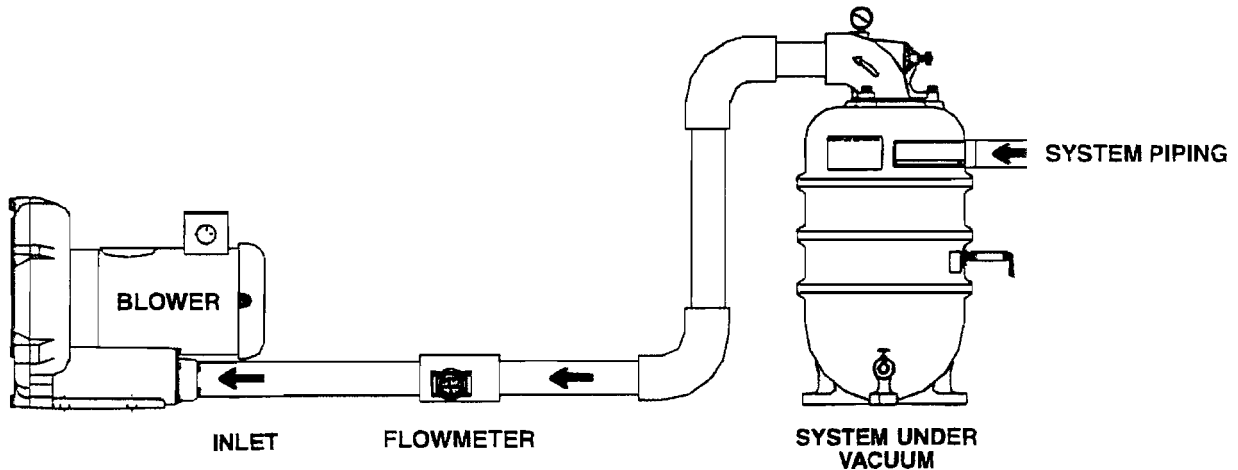
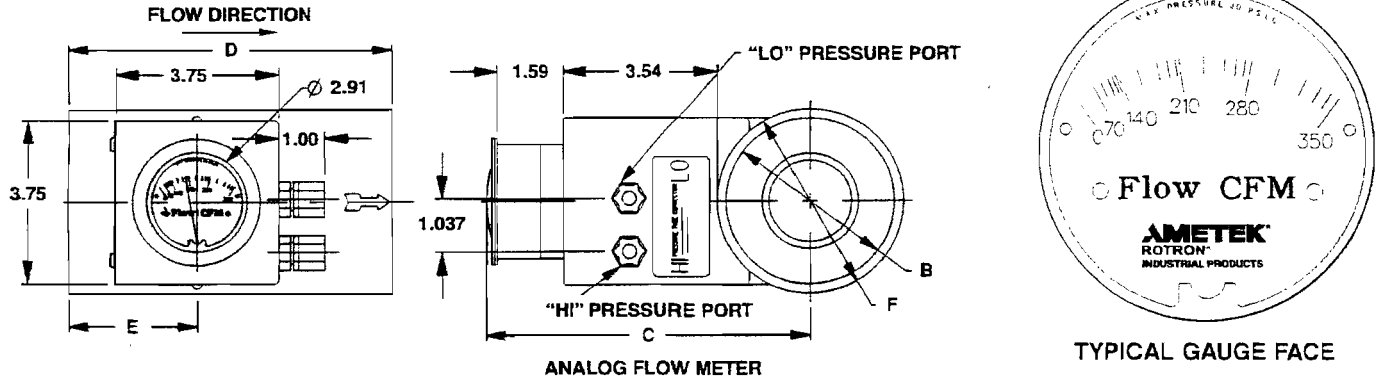

HIGH TEMPERATURE/PRESSURE CORRECTION

$$SCFM_2 = \frac{SCFM_1}{\sqrt{\left(\frac{14.7}{P_{f_2}}\right) \times \left(\frac{530}{T_{f_2} + 460}\right)}}$$

P_{f_2} = Absolute Pressure in PSIA

T_{f_2} = Temperature in °F

- Use on inlet to limit need to correct for high pressure or elevated outlet temperature
- Standard model limits = 140°F and 30 PSIG

HOW IT WORKS

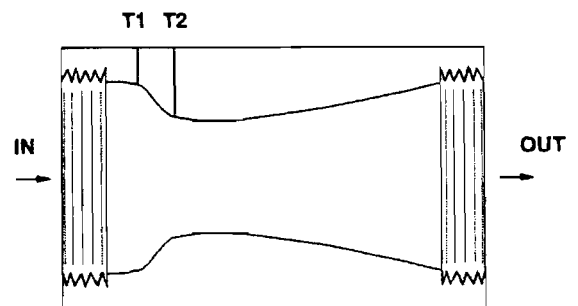

Rotron's flow meter is a venturi style design. After air enters the inlet, the pressure is measured in the T1 tap. The second tap, T2, measures the pressure at the throat. The differential between T1 and T2 registers across a special calibrated CFM gauge to provide accurate readings. The throat is then expanded back to the original size to keep pressure loss to under 2-4 IWG.

Rev. 2/04

OPERATION & MAINTENANCE MANUAL



ROTRON • INDUSTRIAL PRODUCTS
 75 North Street, Saugerties, NY 12477 U.S.A.
 Telephone: 845-246-3401 Fax: 845-246-3802
 e-mail: rotronindustrial@ametek.com website: www.rotronindustrial.com

Air Flow Meter

Thank you for purchasing an AMETEK Rotron Flow Meter. When matched with the correct Rotron blower, and properly installed and maintained, this meter will quickly and accurately measure the pipe flow. To ensure good results, please take the time to read these instructions before starting the installation of your air flow meter.

Sizing for Optimal Efficiency

CURRENT MODELS		FLOW RANGE (SCFM)	THREADS	LENGTH	WIDTH	GAUGE PART #	BODY STYLE	PRIOR MODELS	
MODEL	PART #							MODEL	PART #
FM20C0300	550599	6-30	2.0" 11.5 NPS	6.94"	5.49"	550321	A	FM20A0300	550312
FM20C0450	550600	8-45						FM20A0450	550313
FM20C0650	550601	13-65						FM20A0650	550314
FM20C1250	550602	25-125	2.0" 11.5 NPS	5.34"	5.49"	550290	B	FM20A1250	550256
FM20C1750	550603	35-175						FM20A1750	550255
FM20C2250	550604	45-225						FM20A2250	550254
FM30C2500	550605	50-250	3.0" 8.0 NPS	7.38"	7.62"	550293	C	FM30A2500	550259
FM30C3500	550606	70-350						FM30A3500	550258
FM30C4750	550607	85-475						FM30A4750	550257
FM40C4500	550608	90-450	4.0" 8.0 NPS	7.68"	8.62"	550296	D	FM40A4500	550262
FM40C6000	550609	120-600						FM40A6000	550261
FM40C8500	550610	170-850						FM40A8500	550260

Installation

1. Piping – The flow meter should be installed horizontally on the inlet side of the blower. Since this device is directional, please observe the flow direction arrow. Rotron suggests using a length of straight pipe equivalent to three to five pipe diameters prior to the meter for any elbows, valves, etc., unless there is a tee. If there is a tee, the suggested equivalent length is eight to ten pipe diameters. The flow meter should have two pipe diameters of straight pipe after the flow exits the meter before any elbows, tees, valves, etc.
2. Continuous Service – Moisture and debris should not be allowed to enter the tubes leading into the gauge, as it may affect the gauge. Orient the gauge between 10 o'clock and 2 o'clock when viewed from end. (See Figure 1).

If the gauge does not read zero, gently press down on gauge cover while turning counterclockwise to remove cover. Zero the gauge with the Allen wrench and reattach cover.

INSTALL GAUGE
 10 O'CLOCK TO 2 O'CLOCK

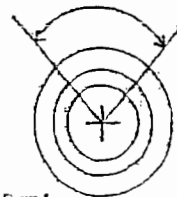

Figure 1

3. Interchangeability – Gauges within a body style are interchangeable to better match your systems actual flow rate to the Gauge Scale. For example:

Body Style	Gauges Available	Flow Range Available
A	550599	6-30 SCFM
A	550600	9-45 SCFM
A	550601	19-65 SCFM

Similar options for each body style are available. Gauges may be purchased separately and field installed without removing the flow meter from the piping.

Typical Arrangement

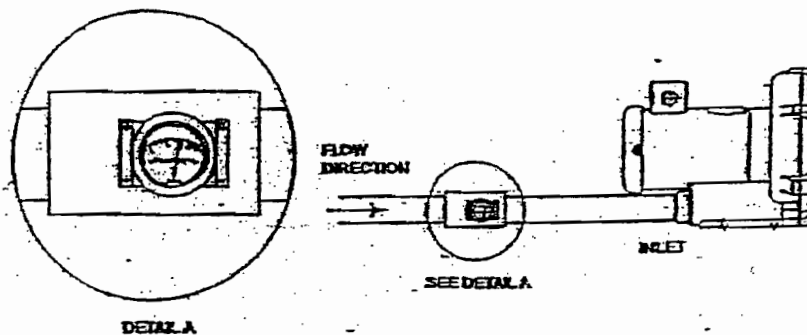

Operation

Rotron's Flow Meter is a venturi style design. After air enters the inlet, the pressure is measured in the high-pressure tap. The second tap measures the pressure at the throat. The differential between the taps registers across a specially calibrated gauge to provide accurate readings. The throat is then expanded back to the original size to keep pressure loss to under 2-4 IWG.

Maintenance

This air flow meter has been designed to require minimal maintenance. During normal operation, little maintenance is required. Care should be taken to ensure no debris enters the meter.

If the tubes become plugged, remove and clean. Do not switch the low and high hoses. Note proper orientation of hoses.

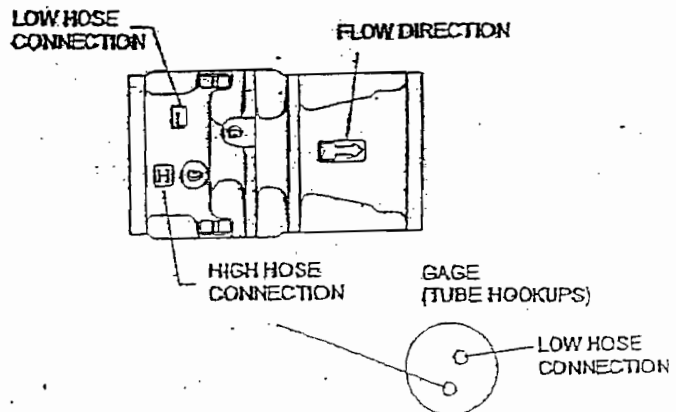



Model L6 FLOTECT® Float Switch

Specifications - Installation and Operating Instructions

Explosion-Proof; UL and CSA Listed -
 Class I, Groups *A, B, C, & D
 Class II, Groups E, F & G
 Directive 94/9/EC (ATEX) Compliant for
 II 2 G EEx d IIC T6 Process Temp ≤ 75°C CE Ⓢ
 *(Group A, stainless steel body only)

SPECIFICATIONS

Service: Liquids compatible with wetted materials.
Wetted Materials:
Float: Solid polypropylene or 304 SS.
Lower Body: Brass or 303 SS.
Magnet: Ceramic.
External Float Chamber (Tee): Matches lower body choice of brass or 303 SS.
Other: Lever Arm, Spring, Pin, etc.: 301 SS.
Temperature Limit: -4 to 220°F (-20 to 105°C) Standard, MT high temperature option 400°F (205°C) (MT not UL, CSA or ATEX). ATEX compliant AT option ambient temperature -4 to 167°F (-20 to 75°C) process temperature: -4 to 220°F (-20 to 105°C).
Pressure Limits: See next page.
Enclosure Rating: Weatherproof and Explosion-proof. Listed with UL and CSA for Class I, Groups A, B, C and D; Class II, Groups E, F, and G. (Group A on stainless steel body models only). CE 0344 Ⓢ II 2 G EEx d IIC T6 Process Temp ≤ 75°C.
 EC-Type Certificate No.: KEMA 04ATEX2128
Switch Type: SPDT snap switch standard, DPDT snap switch optional.
Electrical Rating: UL models: 5A @ 125/250 VAC (V-), CSA and ATEX models: 5A @ 125/250 VAC (V-); 5A res.. 3A ind. @ 30 VDC (V=). MV option: .1A @ 125 VAC (V-). MT option: 5A @ 125/250 VAC (V-). [MT option not UL, CSA or ATEX].
Electrical Connections: UL models: 18 AWG, 16" (460 mm) long. ATEX/CSA models: terminal block.
Upper Body: Brass or 303 SS.
Conduit Connection: 3/4" male NPT standard, 3/4" female NPT on junction box models.
Process Connection: 1" male NPT on models without external float chamber, 1" female NPT on models with external float chamber.
Mounting Orientation: Horizontal with index arrow pointing down.
Weight: Approximately 1 lb (.5 kg) without external float chamber, 1.75 lb (.8 kg) with external float chamber.
Specific Gravity: See next page.

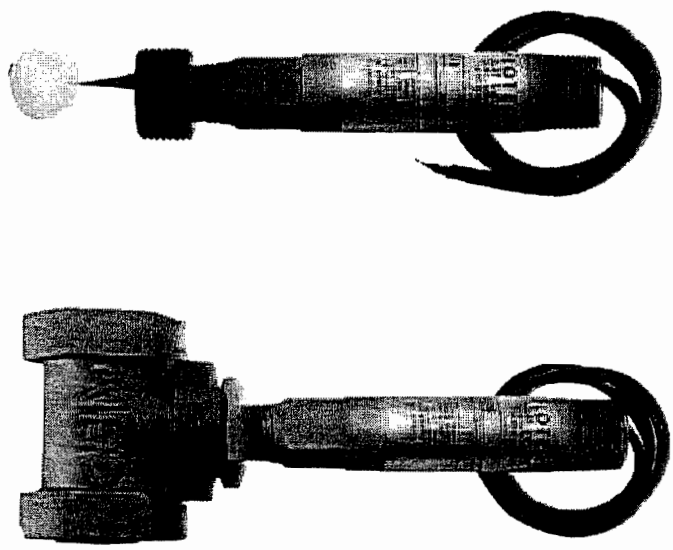

Example	L6	EP	B	B	S	3	B	MT	L6EPB-B-S-3-B-MT level switch; brass upper housing, brass lower housing, brass tee with Polypropylene spherical float, SPDT snap switch, and high temperature option
Series	L6								Series L6 level switch
Construction		EP							Explosion proof and weatherproof
Upper Body Material			B						Brass 303 Stainless Steel
Lower Body Material				B					Brass 303 Stainless Steel
Circuit (Switch) Type					S				SPDT DPDT
Line Size						3			1" NPT 1-1/4" NPT (No tee models only) 1-1/2" NPT (No tee models only) 2" NPT
Tee and Float Options							O A B C H L S		No Tee, Solid Polypropylene Spherical Float* No Tee, 304 SS Cylindrical Float Brass Tee, Solid Polypropylene Spherical Float* No Tee, 304 SS Spherical Float Brass Tee, 304 SS Spherical Float 303 SS Tee, 304 SS Spherical Float 303 SS Tee, Solid Polypropylene Spherical Float*
Switch Options								MV MT	Gold Contacts on snap switch for dry circuits (see specifications for ratings) High Temperature switch rated 400°F (205°C) (see specifications for ratings)*
Options								AT CSA GL ID JCT TBC TOP	ATEX approved construction (with JCT option standard) CSA approved construction (with JCT option standard)* Ground Lead* Customer Information on standard nameplate Weatherproof and explosion-proof junction box* Terminal Block Connector* Top Mounted (No tee models only)*

*Options that do not have ATEX

Attention: Units without the "AT" suffix are not Directive 94/9/EC (ATEX) compliant. These units are not intended for use in potentially hazardous atmospheres in the EU. These units may be CE marked for other Directives of the EU.

MAXIMUM PRESSURE CHART

Model Number	Float	Minimum Sp. Gr.	Pressure Rating psig (bar)
.6EPB-B-S-3-A	Cylindrical SS	0.5	200 (13.8)
.6EPB-B-S-3-B	Polypropylene	0.9	250 (17.2)
L6EPB-B-S-3-C	Round SS	0.7	350 (24.1)
L6EPB-B-S-3-H	Round SS	0.7	250 (17.2)
L6EPB-B-S-3-O	Polypropylene	0.9	1000 (69.0)
L6EPB-S-S-3-A	Cylindrical SS	0.5	200 (13.8)
L6EPB-S-S-3-C	Round SS	0.7	350 (24.1)
L6EPB-S-S-3-L	Round SS	0.7	350 (24.1)
L6EPB-S-S-3-O	Polypropylene	0.9	2000 (138)
L6EPB-S-S-3-S	Polypropylene	0.9	2000 (138)

WETTED MATERIALS CHART

Model	Brass	Bronze	Ceramic	Polypropylene	301SS	303SS	304SS
B-S-3-A	X		X		X		X
B-S-3-B	X	X	X	X	X		
B-S-3-C	X		X		X		X
B-S-3-H	X	X	X		X		X
B-S-3-O	X	X	X	X	X		
S-S-3-A			X	X	X		X
S-S-3-C			X		X	X	X
S-S-3-L			X		X	X	X
S-S-3-O			X	X	X	X	
S-S-3-S			X	X	X	X	

INSTALLATION

Unpack switch and remove any packing material found inside lower housing or float chamber.

Switch must be installed with body in a horizontal plane and arrow on side pointing down.

If switch has an external float chamber (tee), connect it to vertical sections of 1" NPT pipe installed outside vessel walls at appropriate levels. If unit has no external float chamber, it must be mounted in a 1" NPT half coupling welded to the vessel wall. The coupling must extend through the wall.

Inspect and clean wetted parts at regular intervals.

ELECTRICAL CONNECTIONS

Connect wire leads in accordance with local electrical codes and switch action required. N.O. contacts will close and N.C. contacts will open when liquid level causes float to rise. They will return to "normal" condition on decreasing liquid level. Black = common, Blue = N.O. and Red = N.C.

For units supplied with both internal and external grounds the ground screw inside the housing must be used to ground the control. The external ground screw is for supplementary bonding when allowed or required by local code. Some CSA listed models are furnished with a separate green ground wire. Such units must be equipped with a junction box, not supplied but available on special order.

EC-Type Certificate Installation Instructions:

Cable Connection

The cable entry device shall be certified in type of explosion protection flameproof enclosure "d", suitable for conditions of use and correctly installed. For ambient temperatures over 70°C, cable and cable glands suitable for at least 90°C shall be used.

Conduit Connection

An EEx d certified sealing device such as a conduit seal with setting compound shall be provided immediately to the entrance of the valve housing. For ambient temperatures over 70°C, the wiring conduit setting compound in the conduit seal shall be suitable for at least 90°C.

Note: ATEX units only: The temperature class is determined by the maximum ambient and or process temperature. Units are intended to be used in ambient of $-20^{\circ}\text{C} \leq T_{\text{amb}} \leq 75^{\circ}\text{C}$. Units may be used in process temperatures up to 105°C providing the enclosure and switch body temperatures do not exceed 75°C . The standard Temperature Class is T6 Process Temp $\leq 75^{\circ}\text{C}$.

All wiring, conduit and enclosures must meet applicable codes for hazardous areas. Conduits and enclosures must be properly sealed. For outdoor or other locations where temperatures vary widely, precautions should be taken to prevent condensation inside switch or enclosure. Electrical components must be kept dry at all times.

CAUTION: To prevent ignition of hazardous atmospheres, disconnect the device from the supply circuit before opening. Keep assembly tightly closed when in use.

MAINTENANCE

Inspect and clean wetted parts at regular intervals. The cover should be in place at all times to protect the internal components from dirt, dust and weather and to maintain hazardous location ratings. Disconnect device from the supply circuit before opening to prevent ignition of hazardous atmosphere.

VFC Series Visi-Float® Flowmeter

Specifications - Installation and Operating Instructions



Back Connections

Dwyer Series VFC Visi-Float® flowmeters are available in two basic styles, either back or end connected with direct reading scales for air or water. Installation, operation, and maintenance are simple and require only a few common sense precautions to assure long, accurate, trouble-free service.

CALIBRATION

All Dwyer flowmeters are calibrated at the factory and normally will remain within their accuracy tolerance for the life of the device. If at any time you wish to re-check its calibration, do so only with instruments or equipment of certified accuracy. Do not attempt to check the Dwyer Visi-Float® flowmeter with a similar flowmeter as even minor variations in piping and back pressure can cause significant differences between the indicated and actual readings. If in doubt, your Dwyer flowmeter may be returned to the factory and checked for conformance at no charge.

LOCATION

Select a location where the flowmeter can be easily read and where the temperature will not exceed 120°F (49°C). The mounting surface and piping to the flowmeter should be free from vibration which could cause fatigue of fittings or mounting inserts. Piping must be carefully arranged and installed to avoid placing stress on fittings and/or flowmeter body. Avoid locations or applications with strong chlorine atmospheres or solvents such as benzene, acetone, carbon tetrachloride, etc. Damage due to contact with incompatible gases or liquids is not covered by warranty. Compatibility could be carefully determined before placing in service.

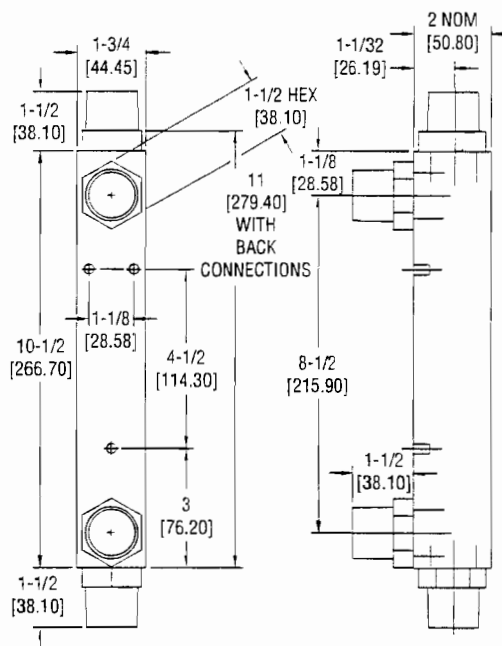
**SPECIFICATIONS**

Service: Compatible gases & liquids.

Wetted Materials:

Body: Acrylic plastic.

O-Ring: Buna-N (Viton® available).

Metal Parts: Stainless steel.

Float: Stainless steel.

Temperature & Pressure Limits: 100 psig (6.9 bar) @ 120°F (48°C).

Accuracy: 2% of full scale.

Process Connection: VFC: 1" female NPT back connections. End connections optional. VFCII: 1" male NPT back connections. End Connections optional.

Scale Length: 5" typical length.

Mounting Orientation: Mount in vertical position.

Weight: 24-25 oz (.68-.71 kg).

PIPING**Inlet Piping:**

It is good practice to approach the flowmeter inlet with as few elbows, restrictions and size changes as possible. Inlet piping should be as close to the flowmeter connection size as practical to avoid turbulence which can occur with drastic size changes. The length of inlet piping has little effect on normal pressure fed flowmeters.

For vacuum service, the inlet piping should be as short and open as possible to allow operation at or near atmospheric pressure and maintain the accuracy of the device. Note that for vacuum service, any flow control valve used must be installed on the discharge side of the flowmeter.

Discharge Piping

Piping on the discharge side should be at least as large as the flowmeter connection. For pressure fed flowmeters on air or gas service, the piping should be as short and open as possible. This allows operation at or near atmospheric pressure and assures the accuracy of the device. This is less important on water or liquid flowmeters since the flowing medium is generally incompressible and back pressure will not affect the calibration of the instrument.

POSITION AND MOUNTING

All Visi-Float® flowmeters must be installed in a vertical position with the inlet connection at the bottom and outlet at the top.

Surface Mounting

Drill three holes in panel using dimensions shown in drawing. Holes should be large enough to accommodate #10 - 32 machine screws. If back connected model, drill two additional holes for clearance of fittings. Install mounting screws of appropriate length from rear. Mounting screws must not be longer than the panel thickness plus 3/16" (9.66 mm), or the screw will hit the plastic and may damage the meter. The screws will require additional force during the initial installation, since the insert boots are of a collapsed thread type and must be expanded into the plastic for the knurled surface to take hold. Insert boots will not have the proper 10-32 threads until the first screw has been inserted to expand the boot. Attach piping using RTV silicone sealant or Teflon® tape on threads to prevent leakage.

CAUTION: Do not overtighten fittings or piping into fittings. Maximum recommended torque is 10 ft. (lbs) (13.56 newton (meter)). Hand tighten only.

In Line Mounting

Both end connected and back connected models may be installed in-line supported only by the piping. Be sure that flowmeter is in a vertical position and that piping does not create excess stress or loading on the flowmeter fittings.

OPERATION

Once all connections are complete, introduce flow as slowly as possible to avoid possible damage. With liquids, make sure all air has been purged before taking readings. Once the float has stabilized, read flow rate by sighting across the largest diameter of the float to the scale graduations on the face of the device.

The standard technique for reading a Variable Area Flowmeter is to locate the highest point of greatest diameter on the float, and then align that with the theoretical center of the scale graduation. In the event that the float is not aligned with a grad, an extrapolation of the float location must be made by the operator as to its location between the two closest grads. The following are some sample floats shown with reference to the proper location to read the float.

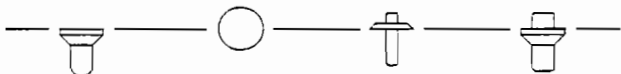

Variable Area Flowmeters used for gases are typically labeled with the prefix "S" or "N", which represents "Standard" for English units or "Normal" for metric units. Use of this prefix designates that the flowmeter is calibrated to operate at a specific set of conditions, and deviation from those standard conditions will require correction for the calibration to be valid. In practice, the reading taken from the flowmeter scale must be corrected back to standard conditions to be used with the scale units. The correct location to measure the actual pressure and temperature is at the exit of the flowmeter, except under vacuum applications where they should

be measured at the flowmeter inlet. The equation to correct for nonstandard operating conditions is as follows:

$$Q_2 = Q_1 \times \sqrt{\frac{P_1 \times T_2}{P_2 \times T_1}}$$

Where: Q_1 = Actual or Observed Flowmeter Reading
 Q_2 = Standard Flow Corrected for Pressure and Temperature

P_1 = Actual Pressure (14.7 psia + Gage Pressure)

P_2 = Standard Pressure (14.7 psia, which is 0 psig)

T_1 = Actual Temperature (460 R + Temp °F)

T_2 = Standard Temperature (530 R, which is 70°F)

Example: A flowmeter with a scale of 10-100 SCFH Air. The float is sitting at the 60 grad on the flowmeter scale. Actual Pressure is measured at the exit of the meter as 5 psig. Actual Temperature is measured at the exit of the meter as 85°F.

$$Q_2 = 60.0 \times \sqrt{\frac{(14.7 + 5) \times 530}{14.7 \times (460 + 85)}}$$

Q_2 = 68.5 SCFH Air

MAINTENANCE

The only maintenance normally required is occasional cleaning to assure proper operation and good float visibility.

Disassembly

The flowmeter can be completely disassembled by removing the connection fittings and top plug. When lifting out the float guide assembly, be careful not to lose the short pieces of plastic tubing on each end of the guide rod which serve as float stops.

Cleaning

The flowmeter body and all other parts can be cleaned by washing in a mild soap and water solution. A soft bristle bottle brush will simplify cleaning of the flow tube. Avoid benzene, acetone, carbon tetrachloride, gasoline, alkaline detergents, caustic soda, liquid soaps, (which may contain chlorinated solvents), etc., and avoid prolonged immersion.

Re-assembly

Install the lower fitting and then the float and float guide. Finally install the upper fitting and plug being certain that both ends of the float guide are properly engaged and the float is correctly oriented. A light coating of silicone stop cock grease or petroleum jelly on the "O" rings will help maintain a good seal as well as ease assembly.

ADDITIONAL INFORMATION

For additional flowmeter application information, conversion curves, correction factors and other data covering the entire line of Dwyer flowmeters, please request a Dwyer full-line catalog.

3989K

Bimetal Thermometers
All Stainless Steel Construction
Back Connection Without External Reset
 Type T1.20

Thermometers

Application

Industrial type design for fluid medium which does not corrode 304 stainless steel.

Size

2" (50.8 mm) - Type T1.20

Accuracy

± 1.0% full scale value (ASME B40.3)

Min. / Max. Ranges

-100°F to 1000°F (and equivalent Celsius)

Working Range

Steady: full scale value
 Shorttime: 110% of full scale value

Under / Over Range Protection

Temporary over or under range tolerance of 50% of scale up to 500°F (260°C). For ranges above 500°F, maximum over range is 800°F; continuous, 1000°F intermittent.

Standard Features

Connection

Material: 304 stainless steel
 Center backmount (CBM)
 1/4" NPT

Stem

Material: 304 stainless steel
 Diameter: 1/8" (6.35 mm)
 Length: 2 1/2" to 24" (63.5 mm to 609.6 mm)

Measuring Element

Bi-metal helix

Case

Material: 304 stainless steel
 Hermetically sealed per ASME B40.3 standard

Dial

White aluminum, dished, with black markings

Pointer

Black aluminum

Standard Scales

Single: Fahrenheit or Celsius
 Dual: Fahrenheit (outer) and Celsius (inner)

Window

Flat instrument glass

Weight

2" - 5 oz.
 Add 1 oz. for every 2" of stem length

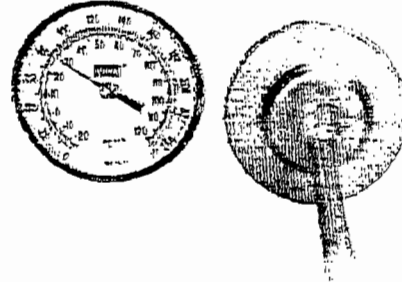

STANDARD RANGES

Fahrenheit	Dual Scale F & C	Celsius
Single Scale	F Outer, C Inner	Single Scale
-100/150 F	-100/150 F & -70/70 C	-50/50 C
-40/120 F	-40/120 F & -40/50 C	-20/120 C
0/140 F	0/140 F & -20/60 C	0/50 C
0/200 F	0/200 F & -15/90 C	0/100 C
0/250 F	0/250 F & -20/120 C	0/150 C
20/240 F	20/240 F & -5/115 C	0/200 C
25/125 F	25/125 F & -5/50 C ¹	0/250 C
50/300 F	50/300 F & 10/150 C	0/300 C
50/400 F	50/400 F & 10/200 C	0/450 C ¹
50/550 F	50/500 F & 10/280 C	100/550 C ¹
150/750 F	150/750 F & 65/400 C	
200/1000 F ¹	200/1000 F & 100/540 C ¹	

¹Not recommended for continuous service over 800°F (425°C)

Dampening

Viscous silicone to minimize pointer oscillation (ranges below 400°F)

Order Options (min. order may apply)

Special scales and dial markings
 Acrylic windows
 Calibration certification traceable to NIST

Dimensions:

Type T1.20

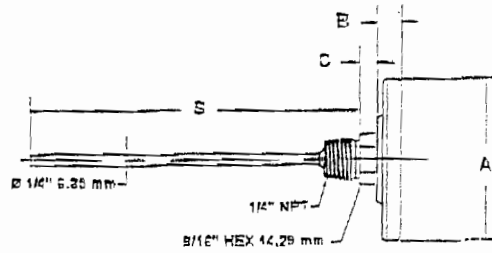

WIKAT TYPE	DIAL SIZE	A	B	C	S (Stem Length)
20	2" (50.8 mm)	12-1/16" (52.4 mm)	7/16" (11.1 mm)	1 1/4" (31.8 mm)	As Labeled

Note: Thermowells for temperature instruments are recommended for all process systems where pressure, velocity, or viscous, abrasive and corrosive materials are present individually or in combination. A properly selected thermowell protects the temperature instrument from possible damage resulting from these process variables. Furthermore, a thermowell permits removal of the temperature instrument for replacement, repair or testing without effecting the process media or the system.

STEM LENGTH
2 1/4" (63.5 mm)
4" (101.6 mm)
6" (152.4 mm)
8" (203.2 mm)
12" (304.8 mm)
15" (381.0 mm)
18" (457.2 mm)
24" (609.6 mm)

Bourdon Tube Pressure Gauges

Dry or Liquid Filled Gauge with SAE Connection

Type 212.53S - Dry Case

Type 213.53S - Liquid-filled Case

WIKA Datasheet 21X.53S

Applications

- ☑ Intended for adverse service conditions where pulsating or vibration exists (with liquid filling)
- ☑ Hydraulics & compressors
- ☑ Suitable for gaseous or liquid media that will not obstruct the pressure system

Special features

- ☑ Vibration and shock resistant (with liquid filling)
- ☑ 7/16" -20 SAE connection
- ☑ Pressure ranges up to 15,000 psi

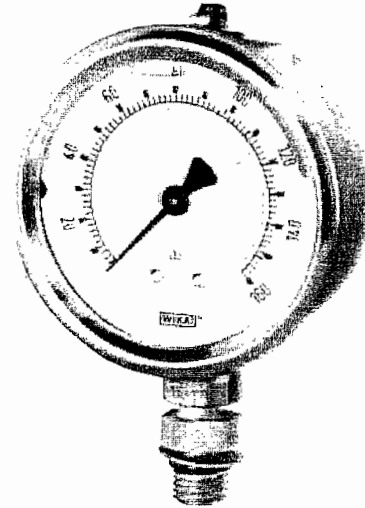

Bourdon Tube Pressure Gauge Model 213.53S

Description

Design

ASME B40.100 & EN 837-1

Sizes

2½" (63 mm)

Accuracy class

± 2/1/2% of span (ASME B40.100 Grade A)

Ranges

Vacuum / Compound to 200 psi
Pressure from 15 psi to 15,000 psi
or other equivalent units of pressure or vacuum

Working pressure

Steady: 3/4 scale value
Fluctuating: 2/3 full scale value
Short time: full scale value

Operating temperature

Ambient: -40°F to +140°F (-40°C to +60°C) - dry
-4°F to +140°F (-20°C to +60°C) - glycerine filled
-40°F to +140°F (-40°C to +60°C) - silicone filled
Medium: +140°F (+60°C) maximum

Temperature error

Additional error when temperature changes from reference temperature of 68°F (20°C) ±0.4% for every 18°F (10°C) rising or falling. Percentage of span.

Weather protection

Weather tight (NEMA 4X / IP 65)

Pressure connection

Material: copper alloy
Lower mount (LM)
7/16" - 20 SAE with o-ring, washer and lock nut

Bourdon tube

Material: copper alloy
≤ 1,000 PSI: C-type
≥ 1,500 PSI: helical type

Movement

Copper alloy

Dial

White ABS with stop pin and with black lettering

Pointer

Black aluminum

Case

304 stainless steel with vent plug and stainless steel crimp ring. Suitable for liquid filling. Case connection sealed with EPDM o-ring (glycerine filled) or Viton o-ring (dry or silicone filled).

Window

Polycarbonate with Buna-N gasket

Case fill

Glycerine 99.7% - Type 213.53S

Optional extras

- ☐ Brass restrictor
- ☐ External zero adjustment (2½" only)
- ☐ Red drag pointer or mark pointer
- ☐ Silicone or Fluorolube case filling
- ☐ Custom dial layout
- ☐ Other pressure scales available
bar, kPa, MPa, kg/cm² and dual scales

Dimensions

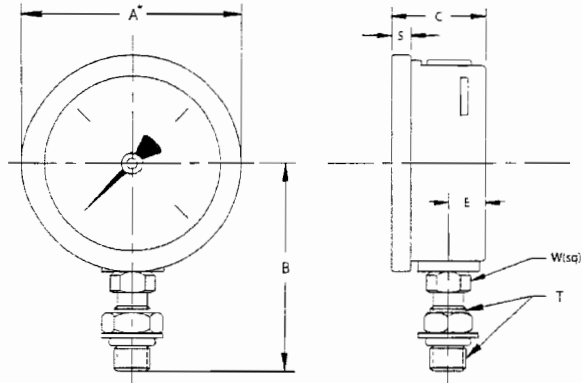

Nominal size		A	B	C	E	S	T	W	W(sq)
2.5"	mm	69	61.2	31	13	6		14	0.38 lb. dry
	in	2.69	2.41	1.23	0.51	0.24	7/16-20	0.55	0.46 lb. filled

Ordering information

Pressure gauge model / Nominal size / Scale range / Size of connection / Optional extras required
Specifications and dimensions given in this leaflet represent the state of engineering at the time of printing
Modifications may take place and materials specified may be replaced by others without prior notice.



WIKA Instrument Corporation

1000 Wiegand Boulevard
Lawrenceville, GA 30045
Tel (770) 513-8200 Toll-free 1-888-WIKA-USA
Fax (770) 338-5118
E-Mail info@wika.com
www.wika.com



APPENDIX D
LABORATORY ANALYTICAL REPORTS

1
2
3
4
5
6
7
8
9
10
11
12
13
14
15
16
17
18
19
20
21
22
23
24
25
26
27
28
29
30
31
32
33
34
35
36
37
38
39
40
41
42
43
44
45
46
47
48
49
50
51
52
53
54
55
56
57
58
59
60
61
62
63
64
65
66
67
68
69
70
71
72
73
74
75
76
77
78
79
80
81
82
83
84
85
86
87
88
89
90
91
92
93
94
95
96
97
98
99
100

Technical Report

prepared for

FPM Group
909 Marconi Avenue
Ronkonkoma, New York 11779
Attention: John Bukoski

*Pilot Test
Results*

Report Date: 9/21/2006

Re: Client Project ID: 891-06-01/45 Kean Street Consulting
York Project No.: 06090316

CT License No. PH-0723

New York License No. 10854



FPM Group
 909 Marconi Avenue
 Ronkonkoma, New York 11779
 Attention: John Bukoski

Purpose and Results

This report contains the analytical data for the sample(s) identified on the attached chain-of-custody received in our laboratory on 09/11/06. The project was identified as your project "891-06-01/45 Kean Street Consulting".

The analyses were conducted utilizing appropriate EPA, Standard Methods, and ASTM methods as detailed in the data summary tables.

All samples were received in proper condition meeting the NELAC acceptance requirements for environmental samples except those indicated under the Notes section of this report.

All the analyses met the method and laboratory standard operating procedure requirements except as indicated under the Notes section of this report, or as indicated by any data flags, the meaning of which is explained in the attachment to this report, if applicable.

The results of the analyses, which are all reported on an as-received basis unless otherwise noted, are summarized in the following table(s).

Analysis Results

Client Sample ID			AS-Test#1 (17cfm)		AS-Test#2 (11cfm)	
York Sample ID			06090316-01		06090316-02	
Matrix			AIR		AIR	
Parameter	Method	Units	Results	MDL	Results	MDL
Volatiles(TO-14 list)	EPA TO-14A	ppbv	---	---	---	---
1,1,1-Trichloroethane			160	2.0	130	2.0
1,1,2,2-tetrachloroethane			Not detected	2.0	Not detected	2.0
1,1,2-Trichloroethane			Not detected	2.0	Not detected	2.0
1,1-Dichloroethane			15	2.0	16	2.0
1,1-Dichloroethylene			Not detected	2.0	Not detected	2.0
1,2,4-Trichlorobenzene			Not detected	2.0	Not detected	2.0
1,2,4-Trimethylbenzene			Not detected	2.0	Not detected	2.0
1,2-Dibromoethane			Not detected	2.0	Not detected	2.0
1,2-Dichlorobenzene			Not detected	2.0	Not detected	2.0
1,2-Dichloroethane			Not detected	2.0	Not detected	2.0
1,2-Dichloropropane			Not detected	2.0	Not detected	2.0
1,2-Dichlorotetrafluoroethane			Not detected	2.0	Not detected	2.0
1,3,5-Trimethylbenzene			Not detected	2.0	Not detected	2.0
1,3-Dichlorobenzene			Not detected	2.0	Not detected	2.0
1,4-Dichlorobenzene			Not detected	2.0	Not detected	2.0
3-Chloropropene			Not detected	2.0	Not detected	2.0

YORK

Client Sample ID			AS-Test#1 (17cfm)		AS-Test#2 (11cfm)	
York Sample ID			06090316-01		06090316-02	
Matrix			AIR		AIR	
Parameter	Method	Units	Results	MDL	Results	MDL
4-Ethyltoluene			Not detected	2.0	Not detected	2.0
Benzene			Not detected	2.0	Not detected	2.0
Benzyl Chloride			Not detected	2.0	Not detected	2.0
Bromomethane			Not detected	2.0	Not detected	2.0
Carbon Tetrachloride			Not detected	2.0	Not detected	2.0
Chlorobenzene			Not detected	2.0	Not detected	2.0
Chloroethane			140	2.0	110	2.0
Chloroform			Not detected	2.0	Not detected	2.0
Chloromethane			Not detected	2.0	Not detected	2.0
cis-1,2-Dichloroethylene			Not detected	2.0	Not detected	2.0
cis-1,3-Dichloropropylene			Not detected	2.0	Not detected	2.0
Dichlorodifluoromethane			Not detected	2.0	Not detected	2.0
Ethylbenzene			Not detected	2.0	Not detected	2.0
Freon-113			Not detected	2.0	Not detected	2.0
Hexachloro-1,3-Butadiene			Not detected	2.0	Not detected	2.0
Methylene Chloride			Not detected	2.0	Not detected	2.0
o-Xylene			Not detected	2.0	Not detected	2.0
p- & m-Xylenes			Not detected	2.0	Not detected	2.0
Styrene			Not detected	2.0	Not detected	2.0
Tetrachloroethylene			58	2.0	54	2.0
Toluene			4.9	2.0	4.9	2.0
trans-1,3-Dichloropropylene			Not detected	2.0	Not detected	2.0
Trichloroethylene			9.3	2.0	8.9	2.0
Trichlorofluoromethane			3.0	2.0	3.0	2.0
Vinyl Chloride			Not detected	2.0	Not detected	2.0
Volatile Organics, TO14 List	EPA TO14A	ug/cu.m.	---	---	---	---
1,1,1-Trichloroethane			888	11.1	721	11.1
1,1,2-tetrachloroethane			Not detected	14.0	Not detected	14.0
1,1,2-Trichloroethane			Not detected	11.1	Not detected	11.1
1,1-Dichloroethane			61.8	8.20	65.9	8.20
1,1-Dichloroethylene			Not detected	8.10	Not detected	8.10
1,2,4-Trichlorobenzene			Not detected	16.6	Not detected	16.6
1,2,4-Trimethylbenzene			Not detected	10.0	Not detected	10.0
1,2-Dibromoethane			Not detected	15.6	Not detected	15.6
1,2-Dichlorobenzene			Not detected	12.0	Not detected	12.0
1,2-Dichloroethane			Not detected	8.20	Not detected	8.20
1,2-Dichloropropane			Not detected	9.40	Not detected	9.40
1,2-Dichlorotetrafluoroethane			Not detected	10.0	Not detected	10.0
1,3,5-Trimethylbenzene			Not detected	10.0	Not detected	10.0
1,3-Dichlorobenzene			Not detected	12.2	Not detected	12.2
1,4-Dichlorobenzene			Not detected	12.1	Not detected	12.1
3-Chloropropene			Not detected	15.0	Not detected	15.0
4-Ethyltoluene			Not detected	10.1	Not detected	10.1
Benzene			Not detected	6.50	Not detected	6.50
Benzyl Chloride			Not detected	11.5	Not detected	11.5
Bromomethane			Not detected	7.90	Not detected	7.90
Carbon Tetrachloride			Not detected	12.8	Not detected	12.8
Chlorobenzene			Not detected	9.40	Not detected	9.40
Chloroethane			376	5.40	295	5.40
Chloroform			Not detected	9.90	Not detected	9.90
Chloromethane			Not detected	4.20	Not detected	4.20

YORK

Client Sample ID			AS-Test#1 (17cfm)		AS-Test#2 (11cfm)	
York Sample ID			06090316-01		06090316-02	
Matrix			AIR		AIR	
Parameter	Method	Units	Results	MDL	Results	MDL
cis-1,2-Dichloroethylene			Not detected	8.10	Not detected	8.10
cis-1,3-Dichloropropylene			Not detected	9.90	Not detected	9.90
Dichlorodifluoromethane			Not detected	10.1	Not detected	10.1
Ethylbenzene			Not detected	8.80	Not detected	8.80
Freon-113			Not detected	15.6	Not detected	15.6
Hexachloro-1,3-Butadiene			Not detected	14.2	Not detected	14.2
Methylene Chloride			Not detected	7.10	Not detected	7.10
o-Xylene			Not detected	8.80	Not detected	8.80
p- & m-Xylenes			Not detected	8.80	Not detected	8.80
Styrene			Not detected	8.70	Not detected	8.70
Tetrachloroethylene			400	13.8	373	13.8
Toluene			18.8	7.70	18.8	7.70
trans-1,3-Dichloropropylene			Not detected	10.1	Not detected	10.1
Trichloroethylene			50.8	10.9	48.6	10.9
Trichlorofluoromethane			17.1	11.4	17.1	11.4
Vinyl Chloride			Not detected	5.20	Not detected	5.20

Client Sample ID			AS-Test#3 (7cfm)		SVE-Test#1 (Max Vac 10in H2O)	
York Sample ID			06090316-03		06090316-04	
Matrix			AIR		AIR	
Parameter	Method	Units	Results	MDL	Results	MDL
Volatiles(TO-14 list)	EPA TO-14A	ppbv	---	---	---	---
1,1,1-Trichloroethane			110	2.0	220	2.0
1,1,2,2-tetrachloroethane			Not detected	2.0	Not detected	2.0
1,1,2-Trichloroethane			Not detected	2.0	Not detected	2.0
1,1-Dichloroethane			13	2.0	11	2.0
1,1-Dichloroethylene			Not detected	2.0	Not detected	2.0
1,2,4-Trichlorobenzene			Not detected	2.0	Not detected	2.0
1,2,4-Trimethylbenzene			Not detected	2.0	Not detected	2.0
1,2-Dibromoethane			Not detected	2.0	Not detected	2.0
1,2-Dichlorobenzene			Not detected	2.0	Not detected	2.0
1,2-Dichloroethane			Not detected	2.0	Not detected	2.0
1,2-Dichloropropane			Not detected	2.0	Not detected	2.0
1,2-Dichlorotetrafluoroethane			Not detected	2.0	Not detected	2.0
1,3,5-Trimethylbenzene			Not detected	2.0	Not detected	2.0
1,3-Dichlorobenzene			Not detected	2.0	Not detected	2.0
1,4-Dichlorobenzene			Not detected	2.0	Not detected	2.0
3-Chloropropene			Not detected	2.0	Not detected	2.0
4-Ethyltoluene			Not detected	2.0	Not detected	2.0
Benzene			Not detected	2.0	Not detected	2.0
Benzyl Chloride			Not detected	2.0	Not detected	2.0
Bromomethane			Not detected	2.0	Not detected	2.0
Carbon Tetrachloride			Not detected	2.0	Not detected	2.0
Chlorobenzene			Not detected	2.0	Not detected	2.0
Chloroethane			89	2.0	Not detected	2.0
Chloroform			Not detected	2.0	Not detected	2.0
Chloromethane			Not detected	2.0	Not detected	2.0
cis-1,2-Dichloroethylene			Not detected	2.0	Not detected	2.0

YORK

Client Sample ID			AS-Test#3 (7cfm)		SVE-Test#1 (Max Vac 10in H2O)	
York Sample ID			06090316-03		06090316-04	
Matrix			AIR		AIR	
Parameter	Method	Units	Results	MDL	Results	MDL
cis-1,3-Dichloropropylene			Not detected	2.0	Not detected	2.0
Dichlorodifluoromethane			Not detected	2.0	Not detected	2.0
Ethylbenzene			Not detected	2.0	Not detected	2.0
Freon-113			Not detected	2.0	Not detected	2.0
Hexachloro-1,3-Butadiene			Not detected	2.0	Not detected	2.0
Methylene Chloride			Not detected	2.0	Not detected	2.0
o-Xylene			Not detected	2.0	Not detected	2.0
p- & m-Xylenes			Not detected	2.0	Not detected	2.0
Styrene			Not detected	2.0	Not detected	2.0
Tetrachloroethylene			50	2.0	60	2.0
Toluene			5.3	2.0	4.2	2.0
trans-1,3-Dichloropropylene			Not detected	2.0	Not detected	2.0
Trichloroethylene			8.7	2.0	11	2.0
Trichlorofluoromethane			Not detected	2.0	3.9	2.0
Vinyl Chloride			Not detected	2.0	Not detected	2.0
Volatile Organics, TO14 List	EPA TO14A	ug/cu.m.	---	---	---	---
1,1,1-Trichloroethane			610	11.1	1220	11.1
1,1,2,2-tetrachloroethane			Not detected	14.0	Not detected	14.0
1,1,2-Trichloroethane			Not detected	11.1	Not detected	11.1
1,1-Dichloroethane			53.5	8.20	45.3	8.20
1,1-Dichloroethylene			Not detected	8.10	Not detected	8.10
1,2,4-Trichlorobenzene			Not detected	16.6	Not detected	16.6
1,2,4-Trimethylbenzene			Not detected	10.0	Not detected	10.0
1,2-Dibromoethane			Not detected	15.6	Not detected	15.6
1,2-Dichlorobenzene			Not detected	12.0	Not detected	12.0
1,2-Dichloroethane			Not detected	8.20	Not detected	8.20
1,2-Dichloropropane			Not detected	9.40	Not detected	9.40
1,2-Dichlorotetrafluoroethane			Not detected	10.0	Not detected	10.0
1,3,5-Trimethylbenzene			Not detected	10.0	Not detected	10.0
1,3-Dichlorobenzene			Not detected	12.2	Not detected	12.2
1,4-Dichlorobenzene			Not detected	12.1	Not detected	12.1
3-Chloropropene			Not detected	15.0	Not detected	15.0
4-Ethyltoluene			Not detected	10.1	Not detected	10.1
Benzene			Not detected	6.50	Not detected	6.50
Benzyl Chloride			Not detected	11.5	Not detected	11.5
Bromomethane			Not detected	7.90	Not detected	7.90
Carbon Tetrachloride			Not detected	12.8	Not detected	12.8
Chlorobenzene			Not detected	9.40	Not detected	9.40
Chloroethane			239	5.40	Not detected	5.40
Chloroform			Not detected	9.90	Not detected	9.90
Chloromethane			Not detected	4.20	Not detected	4.20
cis-1,2-Dichloroethylene			Not detected	8.10	Not detected	8.10
cis-1,3-Dichloropropylene			Not detected	9.90	Not detected	9.90
Dichlorodifluoromethane			Not detected	10.1	Not detected	10.1
Ethylbenzene			Not detected	8.80	Not detected	8.80
Freon-113			Not detected	15.6	Not detected	15.6
Hexachloro-1,3-Butadiene			Not detected	14.2	Not detected	14.2

YORK

Client Sample ID			AS-Test#3 (7cfm)		SVE-Test#1 (Max Vac 10in H2O)	
York Sample ID			06090316-03		06090316-04	
Matrix			AIR		AIR	
Parameter	Method	Units	Results	MDL	Results	MDL
Methylene Chloride			Not detected	7.10	Not detected	7.10
o-Xylene			Not detected	8.80	Not detected	8.80
p- & m-Xylenes			Not detected	8.80	Not detected	8.80
Styrene			Not detected	8.70	Not detected	8.70
Tetrachloroethylene			345	13.8	414	13.8
Toluene			20.3	7.70	16.1	7.70
trans-1,3-Dichloropropylene			Not detected	10.1	Not detected	10.1
Trichloroethylene			47.6	10.9	60.1	10.9
Trichlorofluoromethane			Not detected	11.4	22.3	11.4
Vinyl Chloride			Not detected	5.20	Not detected	5.20

Client Sample ID			SVE-Test#2 (Mod Flow 5in H2O)	
York Sample ID			06090316-05	
Matrix			AIR	
Parameter	Method	Units	Results	MDL
Volatiles (TO-14 list)	EPA TO-14A	ppbv	---	---
1,1,1-Trichloroethane			130	2.0
1,1,2,2-tetrachloroethane			Not detected	2.0
1,1,2-Trichloroethane			Not detected	2.0
1,1-Dichloroethane			5.9	2.0
1,1-Dichloroethylene			Not detected	2.0
1,2,4-Trichlorobenzene			Not detected	2.0
1,2,4-Trimethylbenzene			Not detected	2.0
1,2-Dibromoethane			Not detected	2.0
1,2-Dichlorobenzene			Not detected	2.0
1,2-Dichloroethane			Not detected	2.0
1,2-Dichloropropane			Not detected	2.0
1,2-Dichlorotetrafluoroethane			Not detected	2.0
1,3,5-Trimethylbenzene			Not detected	2.0
1,3-Dichlorobenzene			Not detected	2.0
1,4-Dichlorobenzene			Not detected	2.0
3-Chloropropene			Not detected	2.0
4-Ethyltoluene			Not detected	2.0
Benzene			Not detected	2.0
Benzyl Chloride			Not detected	2.0
Bromomethane			Not detected	2.0
Carbon Tetrachloride			Not detected	2.0
Chlorobenzene			Not detected	2.0
Chloroethane			Not detected	2.0
Chloroform			Not detected	2.0
Chloromethane			Not detected	2.0
cis-1,2-Dichloroethylene			Not detected	2.0
cis-1,3-Dichloropropylene			Not detected	2.0
Dichlorodifluoromethane			Not detected	2.0
Ethylbenzene			Not detected	2.0
Freon-113			Not detected	2.0
Hexachloro-1,3-Butadiene			Not detected	2.0
Methylene Chloride			Not detected	2.0

YORK

Client Sample ID			SVE-Test#2 (Mod Flow 5in H2O)	
York Sample ID			06090316-05	
Matrix			AIR	
Parameter	Method	Units	Results	MDL
o-Xylene			Not detected	2.0
p- & m-Xylenes			Not detected	2.0
Styrene			Not detected	2.0
Tetrachloroethylene			35	2.0
Toluene			4.8	2.0
trans-1,3-Dichloropropylene			Not detected	2.0
Trichloroethylene			6.1	2.0
Trichlorofluoromethane			2.6	2.0
Vinyl Chloride			Not detected	2.0
Volatile Organics, TO14 List	EPA TO14A	ug/cu.m.	---	---
1,1,1-Trichloroethane			721	11.1
1,1,2,2-tetrachloroethane			Not detected	14.0
1,1,2-Trichloroethane			Not detected	11.1
1,1-Dichloroethane			24.3	8.20
1,1-Dichloroethylene			Not detected	8.10
1,2,4-Trichlorobenzene			Not detected	16.6
1,2,4-Trimethylbenzene			Not detected	10.0
1,2-Dibromoethane			Not detected	15.6
1,2-Dichlorobenzene			Not detected	12.0
1,2-Dichloroethane			Not detected	8.20
1,2-Dichloropropane			Not detected	9.40
1,2-Dichlorotetrafluoroethane			Not detected	10.0
1,3,5-Trimethylbenzene			Not detected	10.0
1,3-Dichlorobenzene			Not detected	12.2
1,4-Dichlorobenzene			Not detected	12.1
3-Chloropropene			Not detected	15.0
4-Ethyltoluene			Not detected	10.1
Benzene			Not detected	6.50
Benzyl Chloride			Not detected	11.5
Bromomethane			Not detected	7.90
Carbon Tetrachloride			Not detected	12.8
Chlorobenzene			Not detected	9.40
Chloroethane			Not detected	5.40
Chloroform			Not detected	9.90
Chloromethane			Not detected	4.20
cis-1,2-Dichloroethylene			Not detected	8.10
cis-1,3-Dichloropropylene			Not detected	9.90
Dichlorodifluoromethane			Not detected	10.1
Ethylbenzene			Not detected	8.80
Freon-113			Not detected	15.6
Hexachloro-1,3-Butadiene			Not detected	14.2
Methylene Chloride			Not detected	7.10
o-Xylene			Not detected	8.80
p- & m-Xylenes			Not detected	8.80

YORK

Client Sample ID			SVE-Test#2 (Mod Flow 5in H2O)	
York Sample ID			06090316-05	
Matrix			AIR	
Parameter	Method	Units	Results	MDL
Styrene			Not detected	8.70
Tetrachloroethylene			241	13.8
Toluene			18.4	7.70
trans-1,3-Dichloropropylene			Not detected	10.1
Trichloroethylene			33.3	10.9
Trichlorofluoromethane			14.9	11.4
Vinyl Chloride			Not detected	5.20

Units Key: For Waters/Liquids: mg/L = ppm ; ug/L = ppb For Soils/Solids: mg/kg = ppm ; ug/kg = ppb

Notes for York Project No. 06090316

1. The MDL (Minimum Detectable Limit) reported is adjusted for any dilution necessary due to the levels of target and/or non-target analytes and matrix interference. This MDL is the REPORTING LIMIT and is based upon the lowest standard utilized for calibration where applicable.
2. Samples are retained for a period of thirty days after submittal of report, unless other arrangements are made.
3. York's liability for the above data is limited to the dollar value paid to York for the referenced project.
4. This report shall not be reproduced without the written approval of York Analytical Laboratories, Inc.
5. All samples were received in proper condition for analysis with proper documentation.
6. All analyses conducted met method or Laboratory SOP requirements.
7. It is noted that no analyses reported herein were subcontracted to another laboratory.

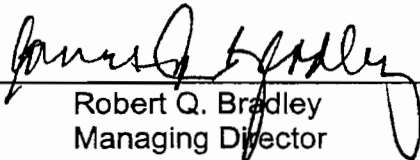
Approved By: 
 Robert Q. Bradley
 Managing Director

Date: 9/21/2006

YORK

YORK

Analytical Laboratories, Inc.

QA/QC Summary Report

Associated Samples: AD08068

21-Sep-06

Client: FPM Group

Analysis Name: **Volatiles(TO-14 list) QA ONLY**
Unit of Measure: ppbv

Batch Name: \$TO14_-21026

QA Sample #: AD08068
York's Sample ID: 06090316-01

Parameter	LCS(%)	Unspiked Result	Blank	Matrix Spike			Spike Duplicate		Precision, RPD
				Amount	Result	Recovery, %	Duplicate	Recovery, %	
1,2-Dichloroethane	Not detected	Not detected	Not detected	Not detected	Not detected	Not detected	Not detected		
Benzyl Chloride	Not detected	Not detected	Not detected	Not detected	Not detected	Not detected	Not detected		
Benzene	5.1	Not detected	Not detected	5.0	4.7	94.0	Not detected		
4-Ethyltoluene	Not detected	Not detected	Not detected	Not detected	Not detected	Not detected	Not detected		
3-Chloropropene	Not detected	Not detected	Not detected	Not detected	Not detected	Not detected	Not detected		
1,4-Dichlorobenzene	Not detected	Not detected	Not detected	Not detected	Not detected	Not detected	Not detected		
1,3-Dichlorobenzene	Not detected	Not detected	Not detected	Not detected	Not detected	Not detected	Not detected		
1,3,5-Trimethylbenz	Not detected	Not detected	Not detected	Not detected	Not detected	Not detected	Not detected		
1,1,1-Trichloroethan	3.8	224	Not detected	Not detected	Not detected	Not detected	232	3.5	
1,2-Dichloropropane	Not detected	Not detected	Not detected	Not detected	Not detected	Not detected	Not detected		
Chlorobenzene	4.8	Not detected	Not detected	5.0	4.5	90.0	Not detected		
1,2-Dichlorobenzene	Not detected	Not detected	Not detected	Not detected	Not detected	Not detected	Not detected		
1,2-Dibromoethane	Not detected	Not detected	Not detected	Not detected	Not detected	Not detected	Not detected		
1,2,4-Trimethylbenz	Not detected	Not detected	Not detected	Not detected	Not detected	Not detected	Not detected		
1,2,4-Trichlorobenze	Not detected	Not detected	Not detected	Not detected	Not detected	Not detected	Not detected		
1,1-Dichloroethylene	4.3	Not detected	Not detected	5.0	3.8	76.0	Not detected		
1,1-Dichloroethane	Not detected	11.1	Not detected	Not detected	Not detected	Not detected	10.9	1.8	
1,1,2-Trichloroethan	Not detected	Not detected	Not detected	Not detected	Not detected	Not detected	Not detected		
1,1,2,2-tetrachloroet	Not detected	Not detected	Not detected	Not detected	Not detected	Not detected	Not detected		
1,2-Dichlorotetrafluo	Not detected	Not detected	Not detected	Not detected	Not detected	Not detected	Not detected		
Freon-113	Not detected	Not detected	Not detected	Not detected	Not detected	Not detected	Not detected		
Trichlorofluorometha	Not detected	3.91	Not detected	Not detected	Not detected	Not detected	4.16	6.2	
Trichloroethylene	4.5	11.1	Not detected	5.0	4.1	82.0	10.8	2.7	
trans-1,3-Dichloropr	Not detected	Not detected	Not detected	Not detected	Not detected	Not detected	Not detected		
Toluene	4.9	4.24	Not detected	5.0	4.5	90.0	4.08	3.8	
Tetrachloroethylene	4.7	59.8	Not detected	Not detected	Not detected	Not detected	59.8	0.0	
Styrene	Not detected	Not detected	Not detected	Not detected	Not detected	Not detected	Not detected		

YORK

YORK

Analytical Laboratories, Inc.

QA/QC Summary Report

p- & m-Xylenes	Not detected	Not detected	Not detected	Not detected	Not detected	Not detected	Not detected
o-Xylene	Not detected	Not detected	Not detected	Not detected	Not detected	Not detected	Not detected
Bromomethane	Not detected	Not detected	Not detected	Not detected	Not detected	Not detected	Not detected
Hexachloro-1,3-Buta	Not detected	Not detected	Not detected	Not detected	Not detected	Not detected	Not detected
Carbon Tetrachloride	Not detected	Not detected	Not detected	Not detected	Not detected	Not detected	Not detected
Ethylbenzene	4.9	Not detected	Not detected	Not detected	Not detected	Not detected	Not detected
Dichlorodifluorometh	Not detected	Not detected	Not detected	Not detected	Not detected	Not detected	Not detected
cis-1,3-Dichloroprop	Not detected	Not detected	Not detected	Not detected	Not detected	Not detected	Not detected
cis-1,2-Dichloroethyl	Not detected	Not detected	Not detected	Not detected	Not detected	Not detected	Not detected
Chloromethane	Not detected	Not detected	Not detected	Not detected	Not detected	Not detected	Not detected
Chloroform	4.2	Not detected	Not detected	Not detected	Not detected	Not detected	Not detected
Chloroethane	Not detected	Not detected	Not detected	Not detected	Not detected	Not detected	Not detected
Vinyl Chloride	5.0	Not detected	Not detected	Not detected	Not detected	Not detected	Not detected
Methylene Chloride	Not detected	Not detected	Not detected	Not detected	Not detected	Not detected	Not detected

YORK

Field Chain-of-Custody Record

0000316

Company Name FPM - group	Report To: JOHN BUKOSKI	Invoice To: SAME AS	Project ID/No. 45 KEAN STREET CONSULTING 891-00-01	Samples Collected By (Signature) <i>Andrew T. McAree</i>	Name (Printed) ANDREW T. MCAREE
------------------------------------	-----------------------------------	-------------------------------	---	--	---

Sample No.	Location/ID	Date Sampled	Sample Matrix				ANALYSES REQUESTED	Container Description(s)
			Water	Soil	Air	OTHER		
1	AS-TEST #1 (17cfm)	9/7/06 11:30am		X			FPM will contact	1x 3 Liter Bag
2	AS-TEST #2 (11cfm)	13:00		X			the laboratory for	1x 3 Liter Bag
3	AS-TEST #3 (7cfm)	14:30		X			intended parameters	1x 3 Liter Bag
4	SVE-TEST #1 (MAX VAC 10" H ₂ O)	9:30am		X				1x 3 Liter Bag
5	SVE-TEST #2 (MOD-FLOW 5" H ₂ O)	10:30am		X				1x 3 Liter Bag

Chain-of-Custody Record	<i>Andrew T. McAree</i> Sample Relinquished by	9/7/06 Date/Time	<i>Andrew T. McAree</i> Sample Received by	 Date/Time
Bottles Relinquished from Lab by				
Bottles Received in Field by				
Comments/Special Instructions	Turn-Around Time <input checked="" type="checkbox"/> Standard <input type="checkbox"/> RUSH(define)			



YORK

ANALYTICAL LABORATORIES, INC.

Technical Report

prepared for:

FPM Group
909 Marconi Avenue
Ronkonkoma, New York 11779
Attention: John Bukoski

Report Date: 7/3/2008

Re: Client Project ID: 891-06-01/45 Keane

York Project No.: 08061070

Effluent #1

CT License No. PH-0723

New Jersey License No. CT-005

New York License No. 10854



Report Date: 7/3/2008
 Client Project ID: 891-06-01 / 45 Keane
 York Project No.: 08061070

FPM Group
 909 Marconi Avenue
 Ronkonkoma, New York 11779
 Attention: John Bukoski

Purpose and Results

This report contains the analytical data for the sample(s) identified on the attached chain-of-custody received in our laboratory on 06/27/08. The project was identified as your project "891-06-01 / 45 Keane".

The analysis was conducted utilizing appropriate EPA, Standard Methods, and ASTM methods as detailed in the data summary tables.

All samples were received in proper condition meeting the NELAC acceptance requirements for environmental samples except those indicated under the Notes section of this report.

All the analyses met the method and laboratory standard operating procedure requirements except as indicated under the Notes section of this report, or as indicated by any data flags, the meaning of which is explained in the attachment to this report, if applicable.

The results of the analyses, which are all reported on an as-received basis unless otherwise noted, are summarized in the following table(s).

Analysis Results

Client Sample ID			Effluent 0626				
Collection Date			06/26/08				
York Sample ID			08061070-01				
Matrix			AIR				
Parameter	Method	Units	Results	MDL	Analysis Date	Analysis Time	Analyst
Volatiles, TO-14 Halogenated List	EPA TO14A	ug/cu.m.	---	---	07/03/08	11:36	SN
1,1,1-Trichloroethane			189	2.22	07/03/08	11:36	SN
1,1,2,2-tetrachloroethane			Not detected	2.80	07/03/08	11:36	SN
1,1,2-Trichloroethane			Not detected	2.22	07/03/08	11:36	SN
1,1-Dichloroethane			Not detected	1.64	07/03/08	11:36	SN
1,1-Dichloroethylene			Not detected	1.62	07/03/08	11:36	SN
1,2,4-Trichlorobenzene			Not detected	3.32	07/03/08	11:36	SN
1,2-Dibromoethane			Not detected	3.12	07/03/08	11:36	SN
1,2-Dichlorobenzene			Not detected	2.40	07/03/08	11:36	SN
1,2-Dichloroethane			Not detected	1.64	07/03/08	11:36	SN
1,2-Dichloropropane			Not detected	1.88	07/03/08	11:36	SN
1,2-Dichlorotetrafluoroethane			Not detected	2.00	07/03/08	11:36	SN
1,3-Dichlorobenzene			Not detected	2.44	07/03/08	11:36	SN
1,4-Dichlorobenzene			Not detected	2.42	07/03/08	11:36	SN
3-Chloropropene			Not detected	3.00	07/03/08	11:36	SN
Benzyl Chloride			Not detected	2.30	07/03/08	11:36	SN
Bromomethane			Not detected	1.58	07/03/08	11:36	SN

Client Sample ID			Effluent 0626				
Collection Date			06/26/08				
York Sample ID			08061070-01				
Matrix			AIR				
Parameter	Method	Units	Results	MDL	Analysis Date	Analysis Time	Analyst
Carbon Tetrachloride			Not detected	2.56	07/03/08	11:36	SN
Chlorobenzene			Not detected	1.88	07/03/08	11:36	SN
Chloroethane			Not detected	1.08	07/03/08	11:36	SN
Chloroform			Not detected	1.98	07/03/08	11:36	SN
Chloromethane			Not detected	0.840	07/03/08	11:36	SN
cis-1,2-Dichloroethylene			Not detected	1.62	07/03/08	11:36	SN
cis-1,3-Dichloropropylene			Not detected	1.98	07/03/08	11:36	SN
Dichlorodifluoromethane			Not detected	2.02	07/03/08	11:36	SN
Freon-113			Not detected	3.12	07/03/08	11:36	SN
Hexachloro-1,3-Butadiene			Not detected	2.84	07/03/08	11:36	SN
Methylene Chloride			Not detected	1.42	07/03/08	11:36	SN
Tetrachloroethylene			255	2.76	07/03/08	11:36	SN
trans-1,3-Dichloropropylene			Not detected	2.02	07/03/08	11:36	SN
Trichloroethylene			38.8	2.18	07/03/08	11:36	SN
Trichlorofluoromethane			28.0	2.28	07/03/08	11:36	SN
Vinyl Chloride			Not detected	1.04	07/03/08	11:36	SN
Volatiles, TO-14 Halogenated List	EPA TO-14	ppbv	---	---	07/03/08	11:36	SN
1,1,1-Trichloroethane			34	2	07/03/08	11:36	SN
1,1,2,2-tetrachloroethane			Not detected	2	07/03/08	11:36	SN
1,1,2-Trichloroethane			Not detected	2	07/03/08	11:36	SN
1,1-Dichloroethane			Not detected	2	07/03/08	11:36	SN
1,1-Dichloroethylene			Not detected	2	07/03/08	11:36	SN
1,2,4-Trichlorobenzene			Not detected	2	07/03/08	11:36	SN
1,2-Dibromoethane			Not detected	2	07/03/08	11:36	SN
1,2-Dichlorobenzene			Not detected	2	07/03/08	11:36	SN
1,2-Dichloroethane			Not detected	2	07/03/08	11:36	SN
1,2-Dichloropropane			Not detected	2	07/03/08	11:36	SN
1,2-Dichlorotetrafluoroethane			Not detected	2	07/03/08	11:36	SN
1,3-Dichlorobenzene			Not detected	2	07/03/08	11:36	SN
1,4-Dichlorobenzene			Not detected	2	07/03/08	11:36	SN
3-Chloropropene			Not detected	2	07/03/08	11:36	SN
Benzyl Chloride			Not detected	2	07/03/08	11:36	SN
Carbon Tetrachloride			Not detected	2	07/03/08	11:36	SN
Chlorobenzene			Not detected	2	07/03/08	11:36	SN
Chloroethane			Not detected	2	07/03/08	11:36	SN
Chloroform			Not detected	2	07/03/08	11:36	SN
Chloromethane			Not detected	2	07/03/08	11:36	SN
cis-1,2-Dichloroethylene			Not detected	2	07/03/08	11:36	SN
cis-1,3-Dichloropropylene			Not detected	2	07/03/08	11:36	SN
Dichlorodifluoromethane			Not detected	2	07/03/08	11:36	SN
Freon-113			Not detected	2	07/03/08	11:36	SN
Hexachloro-1,3-Butadiene			Not detected	2	07/03/08	11:36	SN
Methylene Chloride			Not detected	2	07/03/08	11:36	SN
Tetrachloroethylene			37	2	07/03/08	11:36	SN
trans-1,3-Dichloropropylene			Not detected	2	07/03/08	11:36	SN
Trichloroethylene			7.1	2	07/03/08	11:36	SN
Trichlorofluoromethane			4.9	2	07/03/08	11:36	SN
Vinyl Chloride			Not detected	2	07/03/08	11:36	SN

Units Key: For Waters/Liquids: mg/L = ppm ; ug/L = ppb For Soils/Solids: mg/kg = ppm ; ug/kg = ppb

Report Date: 7/3/2008
Client Project ID: 891-06-01 / 45 Keane
York Project No.: 08061070

Notes for York Project No. 08061070

1. The MDL (Minimum Detectable Limit) reported is adjusted for any dilution necessary due to the levels of target and/or non-target analytes and matrix interference. This MDL is the REPORTING LIMIT and is based upon the lowest standard utilized for calibration where applicable.
2. Samples are retained for a period of thirty days after submittal of report, unless other arrangements are made.
3. York's liability for the above data is limited to the dollar value paid to York for the referenced project.
4. This report shall not be reproduced without the written approval of York Analytical Laboratories, Inc.
5. All samples were received in proper condition for analysis with proper documentation.
6. All analyses conducted met method or Laboratory SOP requirements.
7. It is noted that no analyses reported herein were subcontracted to another laboratory.

Approved By:

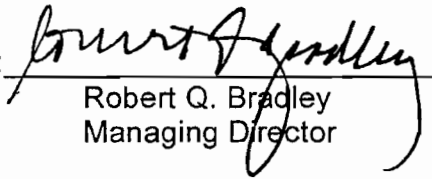
Robert Q. Bradley
Managing Director

Date: 7/3/2008

YORK

Analytical Laboratories, Inc.

QA/QC Summary Report

Associated Samples: AD81370

03-Jul-08

Client: FPM Group

Analysis Name: **Volatiles(TO-14 list) QA ONLY**
Unit of Measure: ppbv

Batch Name: \$TO14_-28878

QA Sample #: AD81370
York's Sample ID: 08061070-01

Parameter	LCS(%)	Unspiked Result	Blank	Matrix Spike			Spike Duplicate		
				Amount	Result	Recovery, %	Duplicate	Recovery, %	Precision, RPD
Benzene	125	Not detected	Not detected	5.0	4.3	86.0	Not detected		
1,1,1-Trichloroethan	113	33.5	Not detected	Not detected	Not detected	Not detected	33.3		0.6
Chlorobenzene	123	Not detected	Not detected	5.0	4.6	92.0	Not detected		
1,1-Dichloroethylene	128	Not detected	Not detected	5.0	4.0	80.0	Not detected		
Trichlorofluorometha	Not detected	4.93	Not detected	Not detected	Not detected	Not detected	4.87		1.2
Trichloroethylene	118	7.13	Not detected	5.0	4.0	80.0	7.03		1.4
Toluene	127	Not detected	Not detected	5.0	4.5	90.0	Not detected		
Tetrachloroethylene	120	37.0	Not detected	Not detected	Not detected	Not detected	36.8		0.5
Ethylbenzene	113	Not detected	Not detected	Not detected	Not detected	Not detected	Not detected		
Chloroform	117	Not detected	Not detected	Not detected	Not detected	Not detected	Not detected		
Vinyl Chloride	101	Not detected	Not detected	Not detected	Not detected	Not detected	Not detected		

YORK

YORK

ANALYTICAL LABORATORIES, INC.

120 RESEARCH DRIVE
STRATFORD, CT 06615
(203) 325-1371 FAX (203) 357-0166

Field Chain-of-Custody Record

08061070

Company Name FPM group		Report To: John Bukoski	Invoice To: same	Project ID/No. 45 Keane 891-06-01	Samples Collected By (Signature) 	Name (Printed) Andrew T. McAuley
----------------------------------	--	-----------------------------------	----------------------------	--	---	--

Sample No.	Location/ID	Date Sampled	Sample Matrix			ANALYSES REQUESTED	Container Description(s)
			Water	Soil	Air		
	Effluent 0626	6/26/08		X		Chlorinated VOC's	1-Tedlar Bag

Chain-of-Custody Record		Sample Relinquished by 	Date/Time 6/26/08
Bottles Relinquished from Lab by	Date/Time	Sample Received by 	Date/Time 6/26/08
Bottles Received in Field by	Date/Time	Sample Received in LAB by 	Date/Time 6/26/08
Comments/Special Instructions Turn-Around Time Standard RUSH(define)			

YORK

ANALYTICAL LABORATORIES, INC.

271 7E
OCT 24 2008

BY: _____

(Handwritten signature)

Technical Report

prepared for:

FPM Group
909 Marconi Avenue
Ronkonkoma, New York 11779
Attention: John Bukoski

Effluent #2

Report Date: 10/21/2008

Re: Client Project ID: 891-08-02 / 45 Kean

York Project No.: 08100459

CT License No. PH-0723

New Jersey License No. CT-005

New York License No. 10854



FPM Group
 909 Marconi Avenue
 Ronkonkoma, New York 11779
 Attention: John Bukoski

Purpose and Results

This report contains the analytical data for the sample(s) identified on the attached chain-of-custody received in our laboratory on 10/10/08. The project was identified as your project "891-08-02 / 45 Kean".

The analyses were conducted utilizing appropriate EPA, Standard Methods, and ASTM methods as detailed in the data summary tables.

All samples were received in proper condition meeting the NELAC acceptance requirements for environmental samples except those indicated under the Notes section of this report.

All the analyses met the method and laboratory standard operating procedure requirements except as indicated under the Notes section of this report, or as indicated by any data flags, the meaning of which is explained in the attachment to this report, if applicable.

The results of the analyses, which are all reported on an as-received basis unless otherwise noted, are summarized in the following table(s).

Analysis Results

Client Sample ID			Effluent	
York Sample ID			08100459-01	
Matrix			AIR	
Parameter	Method	Units	Results	MDL
Volatiles, TO-14 List	EPA TO-14A	ppbv	---	---
1,1,1-Trichloroethane			63	2.0
1,1,2,2-tetrachloroethane			Not detected	2.0
1,1,2-Trichloroethane			Not detected	2.0
1,1-Dichloroethane			Not detected	2.0
1,1-Dichloroethylene			Not detected	2.0
1,2,4-Trichlorobenzene			Not detected	2.0
1,2,4-Trimethylbenzene			Not detected	2.0
1,2-Dibromoethane			Not detected	2.0
1,2-Dichlorobenzene			Not detected	2.0
1,2-Dichloroethane			Not detected	2.0
1,2-Dichloropropane			Not detected	2.0
1,2-Dichlorotetrafluoroethane			Not detected	2.0
1,3,5-Trimethylbenzene			Not detected	2.0
1,3-Dichlorobenzene			Not detected	2.0
1,4-Dichlorobenzene			Not detected	2.0
3-Chloropropene			Not detected	2.0

YORK

Client Sample ID			Effluent	
York Sample ID			08100459-01	
Matrix			AIR	
Parameter	Method	Units	Results	MDL
4-Ethyltoluene			Not detected	2.0
Benzene			7.2	2.0
Benzyl Chloride			Not detected	2.0
Bromomethane			Not detected	2.0
Carbon Tetrachloride			Not detected	2.0
Chlorobenzene			Not detected	2.0
Chloroethane			Not detected	2.0
Chloroform			Not detected	2.0
Chloromethane			Not detected	2.0
cis-1,2-Dichloroethylene			Not detected	2.0
cis-1,3-Dichloropropylene			Not detected	2.0
Dichlorodifluoromethane			Not detected	2.0
Ethylbenzene			Not detected	2.0
Freon-113			Not detected	2.0
Hexachloro-1,3-Butadiene			Not detected	2.0
Methylene Chloride			Not detected	2.0
o-Xylene			Not detected	2.0
p- & m-Xylenes			Not detected	2.0
Styrene			Not detected	2.0
Tetrachloroethylene			20	2.0
Toluene			Not detected	2.0
trans-1,3-Dichloropropylene			Not detected	2.0
Trichloroethylene			2.2	2.0
Trichlorofluoromethane			14	2.0
Vinyl Chloride			Not detected	2.0
Volatiles, TO-14 List	EPA TO14A	ug/cu.m.	---	---
1,1,1-Trichloroethane			350	11.1
1,1,2,2-tetrachloroethane			Not detected	14.0
1,1,2-Trichloroethane			Not detected	11.1
1,1-Dichloroethane			Not detected	8.20
1,1-Dichloroethylene			Not detected	8.10
1,2,4-Trichlorobenzene			Not detected	16.6
1,2,4-Trimethylbenzene			Not detected	10.0
1,2-Dibromoethane			Not detected	15.6
1,2-Dichlorobenzene			Not detected	12.0
1,2-Dichloroethane			Not detected	8.20
1,2-Dichloropropane			Not detected	9.40
1,2-Dichlorotetrafluoroethane			Not detected	10.0
1,3,5-Trimethylbenzene			Not detected	10.0
1,3-Dichlorobenzene			Not detected	12.2
1,4-Dichlorobenzene			Not detected	12.1
3-Chloropropene			Not detected	15.0
4-Ethyltoluene			Not detected	10.1
Benzene			23	6.50
Benzyl Chloride			Not detected	11.5
Bromomethane			Not detected	7.90
Carbon Tetrachloride			Not detected	12.8
Chlorobenzene			Not detected	9.40
Chloroethane			Not detected	5.40
Chloroform			Not detected	9.90
Chloromethane			Not detected	4.20

YORK

Client Sample ID			Effluent	
York Sample ID			08100459-01	
Matrix			AIR	
Parameter	Method	Units	Results	MDL
cis-1,2-Dichloroethylene			Not detected	8.10
cis-1,3-Dichloropropylene			Not detected	9.90
Dichlorodifluoromethane			Not detected	10.1
Ethylbenzene			Not detected	8.80
Freon-113			Not detected	15.6
Hexachloro-1,3-Butadiene			Not detected	14.2
Methylene Chloride			Not detected	7.10
o-Xylene			Not detected	8.80
p- & m-Xylenes			Not detected	8.80
Styrene			Not detected	8.70
Tetrachloroethylene			110	13.8
Toluene			Not detected	7.70
trans-1,3-Dichloropropylene			Not detected	10.1
Trichloroethylene			12	10.9
Trichlorofluoromethane			80	11.4
Vinyl Chloride			Not detected	5.20

Units Key: For Waters/Liquids: mg/L = ppm ; ug/L = ppb For Soils/Solids: mg/kg = ppm ; ug/kg = ppb

Notes for York Project No. 08100459

1. The MDL (Minimum Detectable Limit) reported is adjusted for any dilution necessary due to the levels of target and/or non-target analytes and matrix interference. This MDL is the REPORTING LIMIT and is based upon the lowest standard utilized for calibration where applicable.
2. Samples are retained for a period of thirty days after submittal of report, unless other arrangements are made.
3. York's liability for the above data is limited to the dollar value paid to York for the referenced project.
4. This report shall not be reproduced without the written approval of York Analytical Laboratories, Inc.
5. All samples were received in proper condition for analysis with proper documentation.
6. All analyses conducted met method or Laboratory SOP requirements.
7. It is noted that no analyses reported herein were subcontracted to another laboratory.

Approved By:

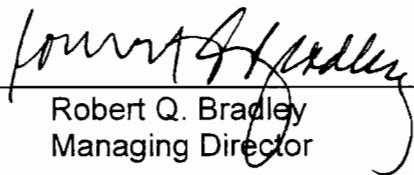
Robert Q. Bradley
Managing Director

Date: 10/21/2008

YORK

YORK

Analytical Laboratories, Inc.

QA/QC Summary Report

Associated Samples: AD95169

21-Oct-08

Client: FPM Group

Analysis Name: **Volatiles(TO-14 list) QA ONLY**
Unit of Measure: ppbv

Batch Name: \$TO14_-30511

QA Sample #: AD95169
York's Sample ID: 08100459-01

Parameter	LCS(%)	Unspiked Result	Blank	Matrix Spike			Spike Duplicate	
				Amount	Result	Recovery, %	Duplicate	Recovery, %
1,2-Dichloroethane	Not detected	Not detected	Not detected	Not detected	Not detected	Not detected	Not detected	
Benzyl Chloride	Not detected	Not detected	Not detected	Not detected	Not detected	Not detected	Not detected	
Benzene	98	Not detected	Not detected	5	5.8	116.0	Not detected	
1-Ethyltoluene	Not detected	Not detected	Not detected	Not detected	Not detected	Not detected	Not detected	
3-Chloropropene	Not detected	Not detected	Not detected	Not detected	Not detected	Not detected	Not detected	
1,4-Dichlorobenzene	Not detected	Not detected	Not detected	Not detected	Not detected	Not detected	Not detected	
1,3-Dichlorobenzene	Not detected	Not detected	Not detected	Not detected	Not detected	Not detected	Not detected	
1,3,5-Trimethylbenz	Not detected	Not detected	Not detected	Not detected	Not detected	Not detected	Not detected	
1,1,1-Trichloroethan	92	Not detected	Not detected	Not detected	Not detected	Not detected	Not detected	
1,2-Dichloropropane	Not detected	Not detected	Not detected	Not detected	Not detected	Not detected	Not detected	
Chlorobenzene	94	Not detected	Not detected	5	5.0	100.0	Not detected	
1,2-Dichlorobenzene	Not detected	Not detected	Not detected	Not detected	Not detected	Not detected	Not detected	
1,2-Dibromoethane	Not detected	Not detected	Not detected	Not detected	Not detected	Not detected	Not detected	
1,2,4-Trimethylbenz	Not detected	Not detected	Not detected	Not detected	Not detected	Not detected	Not detected	
1,2,4-Trichlorobenze	Not detected	Not detected	Not detected	Not detected	Not detected	Not detected	Not detected	
1,1-Dichloroethylene	90	Not detected	Not detected	5	5.4	108.0	Not detected	
1,1-Dichloroethane	Not detected	Not detected	Not detected	Not detected	Not detected	Not detected	Not detected	
1,1,2-Trichloroethan	Not detected	Not detected	Not detected	Not detected	Not detected	Not detected	Not detected	
1,1,2,2-tetrachloroet	Not detected	Not detected	Not detected	Not detected	Not detected	Not detected	Not detected	
1,2-Dichlorotetrafluo	Not detected	Not detected	Not detected	Not detected	Not detected	Not detected	Not detected	
Freon-113	Not detected	Not detected	Not detected	Not detected	Not detected	Not detected	Not detected	
Trichlorofluorometha	Not detected	Not detected	Not detected	Not detected	Not detected	Not detected	Not detected	
Trichloroethylene	108	Not detected	Not detected	5	5.1	102.0	Not detected	
trans-1,3-Dichloropr	Not detected	Not detected	Not detected	Not detected	Not detected	Not detected	Not detected	
Toluene	104	Not detected	Not detected	5	5.6	112.0	Not detected	
Tetrachloroethylene	90	42	Not detected	Not detected	Not detected	Not detected	44	4.7
Styrene	Not detected	Not detected	Not detected	Not detected	Not detected	Not detected	Not detected	

YORK

YORK

Analytical Laboratories, Inc.

QA/QC Summary Report

p- & m-Xylenes	Not detected	Not detected	Not detected	Not detected	Not detected	Not detected	Not detected
o-Xylene	Not detected	Not detected	Not detected	Not detected	Not detected	Not detected	Not detected
Bromomethane	Not detected	Not detected	Not detected	Not detected	Not detected	Not detected	Not detected
Hexachloro-1,3-Buta	Not detected	Not detected	Not detected	Not detected	Not detected	Not detected	Not detected
Carbon Tetrachloride	Not detected	Not detected	Not detected	Not detected	Not detected	Not detected	Not detected
Ethylbenzene	98	Not detected	Not detected	Not detected	Not detected	Not detected	Not detected
Dichlorodifluorometh	Not detected	Not detected	Not detected	Not detected	Not detected	Not detected	Not detected
cis-1,3-Dichloroprop	Not detected	Not detected	Not detected	Not detected	Not detected	Not detected	Not detected
cis-1,2-Dichloroethyl	Not detected	Not detected	Not detected	Not detected	Not detected	Not detected	Not detected
Chloromethane	Not detected	Not detected	Not detected	Not detected	Not detected	Not detected	Not detected
Chloroform	94	Not detected	Not detected	Not detected	Not detected	Not detected	Not detected
Chloroethane	Not detected	Not detected	Not detected	Not detected	Not detected	Not detected	Not detected
Vinyl Chloride	90	Not detected	Not detected	Not detected	Not detected	Not detected	Not detected
Methylene Chloride	Not detected	Not detected	Not detected	Not detected	Not detected	Not detected	Not detected

YORK

08100459

Company Name <u>FPM</u>	Report To: <u>John Bukoski</u>	Invoice To: <u>Same</u>	Project ID/No. <u>4S Kean</u> <u>597-08200</u>	Samples Collected By (Signature) <u>John S. Bukoski</u>		Container Description(s) <u>10 bottles</u>
				Name (Printed) <u>John S. Bukoski</u>		

Sample No.	Location/ID	Date Sampled	Sample Matrix			ANALYSES REQUESTED	Container Description(s)
			Water	Soil	Air		
1	Effluent	10/9/08			X	Chlorinated VOCs	

Chain-of-Custody Record

Bottles Relinquished from Lab by <u>John S. Bukoski</u>	Date/Time <u>10/9/08 16:50</u>	Sample Relinquished by <u>John S. Bukoski</u>	Date/Time <u>10/9/08 16:50</u>
Bottles Received in Field by	Date/Time	Sample Received in LAB by <u>[Signature]</u>	Date/Time <u>10/10/08 10:00</u>
Comments/Special Instructions <u>4.001 Standard</u> RUSH(define)			

