



2018

Remedial Action Work Plan,
South Buffalo Development, Area E
Buffalo, New York

John Black, P.E.

JBlack Consulting, LLC

8/17/2018

Table of Contents

LIST OF FIGURES.....	- 3 -
EXECUTIVE SUMMARY	- 4 -
1 INTRODUCTION.....	- 5 -
2 PROJECT ORGANIZATION.....	- 6 -
3 MOBILIZATION AND SITE CONTROLS.....	- 7 -
3.1 Site Preparation and Earthmoving.....	- 7 -
3.2 Utility Installation.....	- 7 -
4 ODOR, DUST, AND MATERIAL MANAGEMENT CONTROLS.....	- 8 -
4.1 Odor and Dust Control.....	- 8 -
4.2 Material Management.....	- 8 -
5 AIR MONITORING.....	- 9 -
6 STORM WATER AND SEDIMENT CONTROLS.....	- 10 -
7 DESCRIPTION OF REMEDY.....	- 11 -
7.1 Soil Vapor.....	- 11 -
7.2 Soil.....	- 11 -
7.3 Groundwater.....	- 12 -
7.3.1 Area E Shallow Groundwater.....	- 12 -
7.4 GENERAL REQUIREMENTS.....	- 13 -
7.4.1 Future Use of Site.....	- 13 -
7.4.2 Groundwater Use.....	- 13 -
7.4.3 Vapor Intrusion.....	- 13 -
7.4.4 Site Management Plan.....	- 13 -
7.5 CONTINGENCY PLAN.....	- 14 -
8 REMEDIAL ACTIONS.....	- 15 -
8.1 Soil Vapor.....	- 15 -
8.1.1 Soil Vapor Collection.....	- 15 -
8.1.2 Barrier.....	- 16 -
8.2 Soil.....	- 16 -
8.2.1 Perimeter Upgrades.....	- 16 -
8.2.2 Thickness Improvements.....	- 17 -
8.2.3 Storm Water Detention Basino.....	- 17 -

Remedial Action Work Plan
Area E
Former Buffalo Color Corporation

8.3 Groundwater.....- 18 -
 8.3.1 Area E Shallow Groundwater.....- 18 -
8.4 GENERAL REQUIREMENTS- 18 -
 8.4.1 Future Use of Site.....- 19 -
 8.4.2 Groundwater Use.....- 19 -
 8.4.3 Vapor Intrusion- 19 -
 8.4.4 Site Management Plan.....- 19 -
8.5 CONTINGENCY PLAN- 19 -
9 REFERENCES- 21 -
FIGURES.....- 23 -
APPENDICES- 24 -
 A - Health and Safety Plan.....- 25 -
 B - Community Air Monitoring Plan.....- 26 -
 C - Storm Water Pollution Prevention Plan (See Sheets).....- 28 -

LIST OF FIGURES

1	Site Location Map
Sheet 1 of 8	Cover Sheet
Sheet 2 of 8	Existing Conditions Plan
Sheet 3 of 8	Project Site Layout Plan
Sheet 4 of 8	Grading and Drainage Plan
Sheet 5 of 8	Erosion and Sediment Control Plan
Sheet 6 of 8	Typical Sections
Sheet 7 of 8	Paving and Drainage Details
Sheet 8 of 8	Paving and Drainage Details

EXECUTIVE SUMMARY

JBlack Consulting, LLC has prepared this Remedial Action Work Plan (RAWP) under the direction of Inventum Engineering, P.C. on behalf of South Buffalo Development LLC (SBD) for the Buffalo Color Corporation (BCC) Area E Site (Site). The RAWP addresses the activities required to upgrade the existing remedial actions to meet the requirements for restricted residential development as outlined in the Supplemental Alternatives Analysis Report (AAR, JBlack Consulting, 2018). The scope of this RAWP includes:

- Construction Erosion and Sediment Control;
- Dust Control and Community Air Monitoring;
- Cover Improvements;
- Permanent Storm Water Management Facilities;
- Soil Vapor Management Systems; and
- Contingencies.

1 INTRODUCTION

The goal of the remedy selection process in the BCP is to select a remedy for a site that is fully protective of public health and the environment, considering the current, intended and reasonably anticipated future land use of the Area E site. Originally the future use of the Site had been industrial and commercial. The neighborhood in the vicinity of the Site has evolved since the original Alternatives Analysis Report (MACTEC, 2009) and a recreational complex remediated to restricted residential and commercial standards is now anticipated. This Remedial Action Work Plan (RAWP) provides the details of the actions required to upgrade the existing remedial actions to allow recreational use.

This RAWP presents the preferred remedy which has been selected as the final remedy for the Site. The preferred remedy is driven by and consistent with the BCP and SBD's proposed redevelopment approach in that it is:

- Fully protective of human health and the environment;
- Allows for the creation of significant usable property, green space and public access;
- Improves the management of surface water at and from the Site; and
- Meshes well with SBD's and other stakeholders' schedules for accelerated redevelopment of the Site.

2 PROJECT ORGANIZATION

South Buffalo Development, LLC (SBD) will complete the actions required under the RAWP using the following consultants and subcontractors:

1. Owner – South Buffalo Development, LLC
 - a. Contact: Jon Williams
333 Ganson Street
Buffalo, New York 14203
+1 716 856 3333
jmwilliams@oscinc.com
2. Generator – Honeywell, Inc. – Honeywell is responsible for the arranging and offsite disposal of soils generated from the site.
3. Remedial Action Contractor – Ontario Specialty Contracting (OSC) of Buffalo, New York. OSC completed the previous remedial actions at the former Buffalo Color Site.
 - a. Contact: John Yensan
333 Ganson Street
Buffalo, New York 14203
+1 716 856 3333
jyensan@oscinc.com
4. Civil Design – Advanced Design Group – Redevelopment planning and design.
 - a. Contact:
Advanced Design Group
761 Cayuga Street
Lewiston, New York 14092
+1 716 754 2256
_____@____.com
5. Engineer in Responsible Charge – John P. Black, P.E.
 - a. Contact: John P. Black
+1 571 217 6761
JBlackConsulting55@gmail.com
6. Qualified Environmental Professional – Orion Environmental Solutions, LLC (Orion) - full time oversight during construction, monitoring and QA/QC.
 - a. Contact Bryan C. Haan

3 MOBILIZATION AND SITE CONTROLS

Mobilization to the site and site controls will be implemented in stages:

1. Site preparation and earthmoving;
2. Utility Installation; and
3. Vapor Mitigation

The stages are required because the activities are slightly different and present slightly different exposure scenarios and control mechanics.

3.1 Site Preparation and Earthmoving

The Site Preparation and Earthmoving will expose potentially impacted soils under the base of the detention pond and along transition zones that cannot be increased in height by 12-inches simply by removing topsoil and adding 12-inches of clean subbase. The detention pond excavation may encounter groundwater and appropriate contingencies will be in place for liquids management. Mobilization for the site preparation and earthmoving phases of the project will include:

- Establishing the Community Air Monitoring Program (CAMP) stations and initiating upwind and downwind monitoring;
- Establishing the erosion and sediment controls in accordance with the City of Buffalo approved Storm Water Pollution Prevention Plan (SWPPP) presented in Appendix D;
- Establishing work zones in accordance with the Health and Safety Plan (HASP);
- Establishing parking, staging and laydown areas;
- Establishing facilities for the storage and pre-treatment of groundwater; and
- Securing stockpile areas for stripped topsoil.

3.2 Utility Installation

The utility installations will include the stormwater management piping, electrical conduit and limited potable water piping. Although the area of exposed soil will be limited, the base of the excavations for the stormwater piping may encounter groundwater. Mobilization for the utility installation phase of the project will include:

- Establishing the erosion and sediment controls in accordance with the City of Buffalo approved SWPPP presented in Appendix D;
- Establishing work zones in accordance with the HASP;
- Establishing parking, staging and laydown areas; and
- Securing stockpile areas for construction debris.

The CAMP monitoring will be conducted downwind of the excavation daily in accordance with Appendix C.

4 ODOR, DUST, AND MATERIAL MANAGEMENT CONTROLS

The control of odors, dust and the ultimate disposition of materials at and from the site is critical to successful redevelopment of the property. The controls are described below:

4.1 Odor and Dust Control

Odor and dust will be controlled by managing the area of exposed soils, using limited amounts of water to control dust and having covers available to manage odor.

The most effective means of control will be careful earthmoving sequencing:

- a. All site staff will be made aware of the importance of odor and dust control in each morning briefing. Any visible dust crossing the property line will be the cause for immediate dust control mitigation.
- b. Any notable odor at the site boundary will require that (1) the downwind monitor be checked to ensure no exceedance of the CAMP concentrations, and (2) actions be taken to limit the area of soil exposed that is the source of the odor.
- c. Topsoil removal will be limited to one-third of the site at any given time. The topsoil will be managed by stockpiling the top three inches of soil from the first one-third of the site in an area reserved for soil management. The grading will be completed in the first area allowing the topsoil from the second third to be immediately placed on the first one-third.

4.2 Material Management

The material managed at the site will fall into multiple categories and will be addressed as follows:

- a. Topsoil – Topsoil that must be removed to allow increasing the cover thickness to two feet will be either stockpiled onsite or removed and placed on areas that have 21 inches of clean fill cover.
- b. Clean Fill (Soil above demarcation layer) – Soil above the demarcation layer that must be removed to allow excavation along transition areas or below the detention basin will be either stockpiled onsite or removed and placed on areas that have been stripped of topsoil and require additional soil to reach 21 inches of cover (24-inches less the 3-inch topsoil layer).
- c. Potentially Impacted Soil (Soil below Slabs and demarcation layer) – Soils removed from below the demarcation layer (transition areas, sub slab, and below detention pond or sub grade), or soils removed for utility and vapor mitigation installation outside the current cover areas will be loaded in to trucks and transported to offsite permitted disposal facilities. No pre-remediation existing soils will be reused for the redevelopment.
- d. Potentially Impacted Materials (Former demarcation materials, PPE, etc.) – Materials that have, or potentially have, come into contact with soils that existed prior to the remedial action, or that have come into contact with site groundwater, shall be contained and disposed at a licensed offsite disposal facility.
- e. Decontamination or Ground Water – Water generated during remediation (slab cleaning, debris cleaning) or groundwater removed from excavations will be contained, filtered, if necessary, and discharged to the Buffalo Sewer Authority (BSA) under a pre-treatment permit.

5 AIR MONITORING

Air monitoring will be conducted whenever soils that existed at the site prior to the remedial program are exposed during the excavations for the transition areas, detention pond, or utilities. The air monitoring program will be conducted in accordance with the Community Air Monitoring Program (CAMP) included in Appendix C.

6 STORM WATER AND SEDIMENT CONTROLS

Prior to any onsite excavation the storm water and sediment controls detailed in the Storm Water Pollution Prevention Plan (SWPPP) approved by the City of Buffalo (Appendix D) will be installed. All required controls will be maintained and inspected in accordance with the SWPPP.

7 DESCRIPTION OF REMEDY

The Preferred Remedy for the Site consists of the following components:

- Installation of risers to convey sub-slab vapors to heights above the highest roof or parapet elevation;
- Sealing of all slab surfaces in contact with soil;
- Increasing the thickness of the soil covers to no less than 2 feet (including transition zones);
- Maintenance of the cover systems;
- Improving the storm water management system;
- Groundwater monitoring; and
- Maintenance of institutional/engineering controls and environmental easements.

The following subsections provide descriptions of the specific components of the preferred remedy.

7.1 Soil Vapor

To mitigate any potential concern about the presence of volatile organic compounds, an active soil vapor mitigation system will be installed below the slabs that are in contact with site soils.. The soil vapor mitigation system will consist of granular collection media around a perforated pipe, in-line fan(s), and a low permeability membrane placed prior to slab construction. Detailed drawings of the sub-slab system have not been prepared as the exact locations will be dependent on routing around foundations and other obstructions identified after the site has been prepared for foundation construction. As-built drawings will be provided of the exact in-place locations.

The sub-slab system will consist of the following components (top to bottom):

- A concrete slab designed in accordance with, among other requirements, ACI 302.2;
- A 10 mil (minimum) vapor barrier placed immediately above the granular subbase for the concrete slab. All seams in the vapor barrier will be overlapped no less than 6-inches and shall be taped;
- Clean granular collection media, gravel or crushed stone with no fine materials surrounding the perforated tubing placed as follows; and
- 3-inch diameter (minimum) perforated tubing approximately 2 inches below the vapor barrier and placed with no less than 2 -inches of granular material below and on each side of the tubing.

The sub slab system shall be in direct communication with the granular subbase below the concrete slab.

7.2 Soil

The cover system to be utilized as part of the remedy, consistent with the redevelopment of the Site, will involve use of a combination of clean soil, low permeability liners and soil, pavement, or building structures to provide protection from direct contact exposure to potentially contaminated surface soils. As identified in the RI report and illustrated on Figure 20 of the RI (MACTEC 2008), areas that were covered to eliminate the direct contact pathway under a Commercial use scenario exist throughout the Site. Although certain portions of the Site surface soil may in fact meet the restricted residential SCOs, it was considered too difficult to properly delineate and manage these areas during future redevelopment. Thus, the cover system extends across the entire Site. The cover system will be improved to meet the restricted residential standards by providing a minimum of 2 feet of clean soil outside those areas that have a concrete or asphalt cover.

Remedial Action Work Plan
Area E
Former Buffalo Color Corporation

The cover system will interrupt any direct contact pathway, reduce infiltration of precipitation through impacted soil into groundwater and promote surface drainage.

The cover system will consist of a minimum of two feet of soil, a membrane liner with 24-inches of soil, asphalt or concrete pavement (with appropriate granular subbase), or building structures, consistent with the presumptive remedy as identified in 6 NYCRR Part 375.

Along the intersections of the existing cover and the perimeter pavement/slabs and below the proposed storm water pond, the entire cover system will have to be removed (Figure C-100). Up to an additional one foot of soil will be removed from limited areas to allow increasing the cap thickness to a minimum of two feet. In those locations where the existing cover will be completely removed, a demarcation layer will be placed between existing surface soils and any new soil cover materials so the boundary between clean fill and existing Site soils can be identified in the future. The existing demarcation layer will be protected under those portions of the cap that will be upgraded from one foot thick to a minimum of two feet without additional excavation.

All soils excavated (Figures E-200 and E-201 and Appendix A) from below the existing cover system will be directly loaded into trucks or staged on polyethylene sheeting either on a paved area, or occupied, on existing Site soils. The soils will be sampled and disposed offsite in a permitted landfill.

Best Management Practices will be implemented to manage storm water runoff, erosion, and dust, as appropriate (Appendices A, C and D). Construction management and cleaning will be implemented to ensure soil is not tracked from the site onto the surrounding public roadways.

7.3 Groundwater

Due to the variability of shallow groundwater conditions across the Site, a multi-faceted remedy was selected to address Site groundwater in the shallow aquifer and attain the groundwater RAOs as described in the following subsections. The long-term goal of groundwater remediation is restoration of groundwater to its classified use; the short-term goal was plume stabilization, which has been achieved.

Depending on the conditions at the time of the storm water detention pond construction, groundwater may be encountered in the excavation. All groundwater recovered from the excavation will be contained and tested prior to discharge to the Buffalo Sewer Authority (BSA) or transported to an offsite facility. All water discharged will be done under the proper authorizations and permits.

In addition to the remedy components specific to groundwater, the implementation of a thicker Site-wide cover system and improved storm water management will serve to further reduce surface water infiltration and minimize the soil-to-groundwater migration pathway.

7.3.1 Area E Shallow Groundwater

Alternative GW-E-2 (Enhanced Bioremediation and Groundwater Monitoring) had been selected as the preferred alternative for the Area E shallow groundwater. Alternative GW-C-2 included in-situ enhanced bioremediation of the limited chlorobenzene plumes identified at Area E. The full-scale implementation was completed, and the sampling data has demonstrated the effectiveness of the treatment.

The long-term goal of groundwater remediation is restoration of groundwater to its classified use; the short-term goal is plume stabilization. The criteria for determining success for the biotreatment process will continue to be based on confirmation through groundwater monitoring that concentrations of COCs in the plume have been reduced and that the plume is not migrating beyond the Site. Only samples from three monitoring wells have detections of chlorobenzene above the MDL, RFI-29, RFI-32A, and MW-E05. None

Remedial Action Work Plan
Area E
Former Buffalo Color Corporation

of these wells are under the complex. There are no detectable concentrations of VOCs in samples from RFI-17 near the proposed Field House.

7.4 GENERAL REQUIREMENTS

The general requirements, including institutional/engineering controls and environmental easements, which must be maintained as part of the preferred remedy for the Site are defined below.

7.4.1 Future Use of Site

Environmental easements/deed notices have been implemented to ensure that the Site can be used only for commercial or industrial purposes (as the terms are defined in 6 NYCRR Part 375-1). The environmental easements/deed notices will be amended to allow restricted residential use after the Site is remediated to meet restricted residential use standards. The environmental easements and deed notices will be described in detail as part of the Institutional and Engineering Control Plan (which are included in the Site Management Plan).

7.4.2 Groundwater Use

The potable or consumptive use of groundwater (which is prohibited by City of Buffalo ordinance) have been further prohibited at the Site through implementation of an environmental easement/deed notice.

7.4.3 Vapor Intrusion

An environmental easement will be implemented to ensure that occupied structures associated with future development at the Site are constructed such that the vapor intrusion (VI) pathway is eliminated. This will be accomplished through the installation of vapor barriers and an active subgrade vapor collection system(s).

7.4.4 Site Management Plan

A Site Management Plan was prepared for the Site, consistent with 6 NYCRR Part 375 and the Guide. The plan includes the following components:

- Introduction, background, and summary of RI results;
- An Institutional and Engineering Control Plan;
- A Soil Fill Management Plan that specifies requirements for excavation/grading activities, stockpiling and soil staging areas, waste characterization sampling, onsite reuse criteria, soil loading and transportation, and requirements for offsite disposal;
- Health and Safety for construction personnel, including requirements for Site and community air monitoring;
- A Quality Assurance/Quality Control Plan;
- An Operations, Maintenance and Monitoring Plan;
- Notification and reporting requirements; and
- Tables, figures and appendices, as necessary.

An environmental easement has been implemented that requires that any excavation or other disturbance of Site soil meets the requirements of the Site Management Plan. The Site Management Plan and environmental easements will be updated to address the recreational use.

7.5 CONTINGENCY PLAN

During remedial construction, it may be appropriate for SBD to consider alternative or additional measures to facilitate remediation of the Site consistent with the Preferred Remedial Alternative set forth herein. Those measures which SBD may, at its discretion, consider include:

- Sub-slab Barrier;
- Soil Excavation and Offsite Disposal;
- Sub-liner groundwater collection system; or
- New Paving.

Prior to implementation of any of the above listed contingency items, a Work Plan will be prepared that details the scope and schedule for the proposed activities. The Work Plan will be submitted to NYSDEC for review and approval.

8 REMEDIAL ACTIONS

The following subsections and the Drawings provide descriptions of the specific actions required to implement each component of the preferred remedy.

8.1 Soil Vapor

Although there are no detected VOCs in groundwater in the vicinity of the proposed Field House, vapor mitigation will be installed. The soil vapor mitigation system will consist of granular collection media around a perforated pipe, an in-line fan, and a low permeability barrier below all soil contact level concrete slabs.

8.1.1 Soil Vapor Collection

The soil vapor collection system will consist of permeable media surrounding a system of perforated piping. The system will be installed at the locations shown as Existing Schoellkopf Powerhouse in Appendix E. The activities required for installation include:

- Excavation of soils to a depth of no less than 8-inches below the base of the slab. For purposes of this excavation, the base of the slab shall be defined as the lowest point of the typical slab (not including foundations or grade beams) along each run of the collection system. The base of the excavation along each run shall be level;
- Removal of any water that accumulates in the excavation. All water shall be containerized, tested and discharged to the BSA or transported offsite as required by the appropriate authorizations and permits;
- Placement of a uniform 2-inch thick base of No. 1 aggregate.
- Placement of 3-inch diameter perforated tubing along the centerline of each run.
 - All joints shall be taped to ensure they stay joined during aggregate placement; and
 - End caps shall be used to limit the possibility of drawing fines into tubing.
- Installation of a solid 90-degree PVC elbow at the end of each run with a riser. The riser will be fitted with a temporary 3 - foot tall (minimum) riser and end cap. A four-inch, minimum, corrugated HDPE sleeve shall be placed around the temporary riser, from the elbow to 1 inch (minimum) above the surrounding slab elevation. The sleeve shall be held in place with temporary wedges to ensure the riser remains centered during aggregate and concrete placement;
- Placement of No. 1 aggregate on each side and over the perforated tubing. The aggregate shall be placed in a manner to avoid shifting the tubing, disturbing the joints, or crushing/pinching the tubing;
- Metallic utility locating tap shall be placed on the aggregate above the centerline of the aggregate;
- The utility tape and aggregate shall be covered with a layer of 10 mil (Minimum) polyethylene sheeting. The joints in the polyethylene sheeting shall overlap a minimum of 6 inches and be taped;
- Vacuum monitoring points shall be placed in each slab area as shown in Appendix E;
- Placement of a reinforced concrete slab to match the surrounding slab elevations. The slab shall be reinforced in accordance with standards for the assumed loading; and
- The concrete shall be covered for no less than 7 days to minimize cracking.

8.1.2 Barrier

The barrier system will complement the soil vapor collection and conveyance systems and will be installed on all interior slabs that are in contact with soil. The barrier system installation will involve the following actions:

- The barrier system will be installed after the completion of the soil vapor collection and conveyance systems;
- The barrier system will consist of a membrane over the entire area to be covered with a building slab. The membrane will be sealed to all foundations, perimeter foundation walls, and utility penetrations.

8.2 Soil

The current cover system at the Site does not meet the requirements of the proposed restricted residential use. The soil cover system will be improved as shown on Drawings No. E-201. The improvements fall into three categories; slab/perimeter upgrades; thickness improvements; and the storm water basin. The sequence of cover improvements will be determined in the field. The activities required for each are described below and in the Drawing E-201.

8.2.1 Perimeter Upgrades

The perimeter upgrades have been designed to allow increasing the thickness of the cover without creating discontinuity along the perimeter of the soil cover system. The activities associated with these areas include:

- Establishing erosion and sediment controls in accordance with the approved SWPPP (Appendix D). The erosion and sediment controls will follow best management practices for conditions where a silt fence is not practical;
- Establishing the community air monitoring program (CAMP);
- Removal and stockpiling of the top soil. The top three inches of the current cover system will be removed from the perimeter area and stockpiled or placed directly on areas with 21-inches of clean fill. The stockpile will be staged, covered and clearly identified for reuse;
- Removal and stockpiling of the clean soil cover above the marker layer. The remainder of the current cover system will be removed from the perimeter area and stockpiled. The stockpile will be staged, covered and clearly identified for reuse;
- The marker layer will be cut at the interface with the cover/marker to remain. The section over the perimeter area will be removed and properly disposed;
- The soils currently below the marker layer that are identified for removal (Drawing No.C-201C-201) will be excavated and stockpiled on polyethylene sheeting on a paved area or if occupied over Site soils. The stockpiled soils will be sampled and disposed offsite in a landfill permitted to receive the compounds detected in the sampling;
- Any loose stones or protrusions that could damage the marker layer will be removed;
- Any perimeter retaining walls that are damaged or potentially unstable will be repaired, replaced or removed;
- A demarcation/marker layer will be placed across the surface of the subgrade. The marker layer will extend from the perimeter pavement to the pre-existing marker layer;

**Remedial Action Work Plan
Area E
Former Buffalo Color Corporation**

- The soils removed from the top of the previous marker layer that were below the topsoil shall be placed in lifts of no more than 6-inches to cover the marker. The soil will be placed in a manner that it does not damage or disrupt the marker layer;
- Additional clean soils will be placed to increase the thickness of the cover system to no less than 21-inches. The additional soils will be placed in 6-inch maximum lifts and shall be compacted with no less than three passes of a roller;
- A minimum of 3-inches of topsoil recovered from the existing cover system will be placed over the 21-inch base.
- The topsoil shall be fertilized, limed, seeded and mulched; and
- The seeding shall be monitored until there is an established stand of vegetation to prevent erosion.

8.2.2 Thickness Improvements

The cover system upgrades have been designed to allow increasing the thickness of the cover to meet the requirements of the restricted residential use. The activities associated with these areas include:

- Establishing erosion and sediment controls in accordance with the City of Buffalo approved SWPPP (Appendix D). The erosion and sediment controls will follow best management practices for conditions where a silt fence is not practical;
- Establishing the community air monitoring program (CAMP);
- Removal and stockpiling of the top soil. The top three inches of the current cover system will be removed from the perimeter area and stockpiled or placed directly on areas with 21-inches of clean fill. The stockpile will be staged, covered and clearly identified for reuse;
- Additional clean soils will be placed to increase the thickness of the unclassified soil in the cover system (including all transition areas) to no less than 21-inches (which with the topsoil will be no less than 24-inches total). The additional soils will be placed in 6-inch maximum lifts and shall be compacted with no less than three passes of a roller;
- A minimum of 3-inches of topsoil recovered from the existing cover system will be placed over the 21-inch base;
- The topsoil shall be fertilized, limed, seeded and mulched; and
- The seeding shall be monitored until there is an established stand of vegetation to prevent erosion.

8.2.3 Storm Water Detention Basins

The construction of the storm water basin requires a deeper excavation than is necessary for cover construction. The excavation of the storm water basin void will extend to a depth of 5.5 feet (849.5 feet above mean sea level [ft-msl]). The excavation will include the basin and the utility corridors for the storm water piping. The activities associated with these areas include:

- Establishing erosion and sediment controls. The erosion and sediment controls will follow best management practices for conditions where a silt fence is not practical;
- Establishing the community air monitoring program (CAMP);
- Removal and stockpiling of the top soil. The top three inches of the current cover system will be removed from the storm water pond area and stockpiled or placed directly on areas that have been prepared with 18-inches of unclassified soil. The stockpile, if used, will be staged, covered and clearly identified for reuse;
- Removal and stockpiling of the clean soil cover above the marker layer or use of the soil in other areas that require additional fill. The remainder of the current cover system will be removed from

Remedial Action Work Plan
Area E
Former Buffalo Color Corporation

the perimeter area and stockpiled. The stockpile, if used, will be staged, covered and clearly identified for reuse;

- The marker layer will be cut at the interface with the cover/marker to remain. The section over the storm water basin and storm water piping will be removed and properly disposed;
- The soils currently below the marker layer that are identified for removal (Figures E-200 and E-201) will be excavated and loaded for offsite disposal. The stockpiled soils will be pre-sampled and disposed offsite in a landfill permitted to receive the compounds detected in the sampling;
- Any loose stones or protrusions that could damage the pond liner will be removed;
- 200 pounds of ORC shall be uniformly spread and blended into the top 6-inches of soil over the eastern one-half of the excavation base. The excavation base shall be compacted prior to placement of the geotextile;
- A layer of non-woven geotextile (GSE CE Nonwoven needle-punched geotextile, CE3 or approved substitute) will be placed across the surface of the subgrade. The non-woven geotextile will extend from the anchor trench on all perimeters to the anchor trench on the opposite side of the pond;
- The single membrane liner system will be placed over the geotextile and into the anchor trench around the storm water pond;
- The boots for the storm water piping will be installed and sealed to the pipes;
- 18-inches of soil will be placed on the based of the detention basin excavation and 21-inches of clean fill will be placed on the slopes of the detention basin excavation;
- A layer of geotextile will be placed in the areas of rip rap (Drawing No. E-201); Rip rap will be placed in the locations shown on the plan (Drawing No. E-201);
- The soils removed from the top of the previous marker layer that were below the topsoil shall be placed in lifts of no more than 6-inches to cover the liner. The soil will be placed in a manner that it does not damage or disrupt the liner;
- The topsoil shall be fertilized, limed, seeded and mulched; and
- The seeding shall be monitored until there is an established stand of vegetation to prevent erosion.

8.3 Groundwater

The groundwater has been remediated and the ongoing monitoring is expected to show continued reductions in groundwater concentrations.

8.3.1 Area E Shallow Groundwater

Alternative GW-E-2 (Enhanced Bioremediation and Groundwater Monitoring) had been selected as the preferred alternative for the Area E shallow groundwater. The long-term goal of groundwater remediation is restoration of groundwater to its classified use; the short-term goal is plume stabilization. The criteria for determining success for the biotreatment process will continue to be based on confirmation through groundwater monitoring that concentrations of COCs in the plume have been reduced and that the plume is not migrating beyond the Site.

8.4 GENERAL REQUIREMENTS

The general requirements, including institutional/engineering controls and environmental easements, which must be maintained as part of the preferred remedy for the Site are defined below.

**Remedial Action Work Plan
Area E
Former Buffalo Color Corporation**

8.4.1 Future Use of Site

Environmental easements/deed notices have been implemented to ensure that the Site can be used only for commercial or industrial purposes (as the terms are defined in 6 NYCRR Part 375-1). The environmental easements/deed notices will be amended or replaced to allow restricted residential use after the Site is remediated to meet restricted residential standards. The environmental easements and deed notices will be described in detail as part of the Institutional and Engineering Control Plan (which are included in the Site Management Plan).

8.4.2 Groundwater Use

The potable or consumptive use of groundwater (which is prohibited by City of Buffalo ordinance) have been further prohibited at the Site through implementation of an environmental easement/deed notice.

8.4.3 Vapor Intrusion

An environmental easement will be implemented to ensure that occupied structures associated with future development at the Site are constructed such that the vapor intrusion (VI) pathway is eliminated. This will be accomplished through the installation of vapor barriers and an active subgrade vapor collection system(s).

8.4.4 Site Management Plan

A Site Management Plan was prepared for the Site, consistent with 6 NYCRR Part 375 and the Guide. The plan includes the following components:

- Introduction, background, and summary of RI results;
- An Institutional and Engineering Control Plan;
- A Soil Fill Management Plan that specifies requirements for excavation/grading activities, stockpiling and soil staging areas, waste characterization sampling, onsite reuse criteria, soil loading and transportation, and requirements for offsite disposal;
- Health and Safety for construction personnel, including requirements for Site and community air monitoring;
- A Quality Assurance/Quality Control Plan;
- An Operations, Maintenance and Monitoring Plan;
- Notification and reporting requirements; and
- Tables, figures and appendices, as necessary.

An environmental easement has been implemented that requires that any excavation or other disturbance of Site soil meets the requirements of the Site Management Plan. The Site Management Plan will be updated to address the restricted residential use and the new institutional controls.

8.5 CONTINGENCY PLAN

During remedial construction, it may be appropriate for SBD to consider alternative or additional measures to facilitate remediation of the Site consistent with the Preferred Remedial Alternative set forth herein. Those measures which SBD may, at its discretion, consider include:

- Sub-slab Barrier;
- Soil Excavation and Offsite Disposal;
- Sub-liner groundwater collection system; or
- New Paving.

Remedial Action Work Plan

Area E

Former Buffalo Color Corporation

Prior to implementation of any of the above listed contingency items, a Work Plan will be prepared that details the scope and schedule for the proposed activities. The Work Plan will be submitted to NYSDEC for review and approval.

9 REFERENCES

The following is a list of significant references used by MACTEC and JBlack Consulting in preparation of this report. Other documents, including project correspondence documents and records maintained in Buffalo Color Corporation files, were used to supplement the information obtained from the references listed below.

- 6NYCRR Part 375, 2006, December.
- Benchmark Environmental Engineering & Science, PLLC, June 2017, “Soil Vapor Intrusion Investigation Report”, Former Buffalo Color Corporation Site – Area E, 140 Lee Street, Buffalo, New York.
- Golder Associates, November 1997, “Final Report on RCRA Facility Investigation, Buffalo Color Corporation, Buffalo, New York.”
- Golder Associates, December 1998, “Addendum to Final Report on RCRA Facility Investigation, Buffalo Color Corporation, Buffalo, New York.”
- Golder Associates, January 2000, “Report on Corrective Measures Study, Buffalo Color Corporation, Buffalo, New York.”
- MACTEC Engineering and Consulting, March 2006, “Final Operations, Maintenance & Monitoring Plan, Interim Corrective Measure, Buffalo Color Area ABCE, Buffalo, New York.”
- MACTEC Engineering and Consulting, August 2008, “Remedial Investigation Report, Buffalo Color Corporation, Area ABCE Site, Buffalo, New York.”
- MACTEC Engineering and Consulting, February 2009, “Alternatives Analysis Report, Former Buffalo Color Corporation Site, Buffalo, New York.”
- MACTEC Engineering and Consulting, 2010, “Final Engineering Report, Former Buffalo Color Corporation Site, Buffalo, New York”, December.
- MACTEC Engineering and Consulting, 2010, “Site Management Plan, Former Buffalo Color Corporation Site, Buffalo, New York”, December.
- New York State Department of Environmental Conservation (NYSDEC), 1989. Technical and Administrative Guidance Memorandum HWR 89- 4031: Fugitive Dust Suppression and Particulate Monitoring Program. October 1989.
- New York State Department of Environmental Conservation (NYSDEC), 1990. Technical and Administrative Guidance Memorandum HWR 90- 4030: Selection of Remedial Actions at Inactive Hazardous Waste Sites. May 1990.
- New York State Department of Environmental Conservation, May 15, 1991, letter to G. Bolles (Buffalo Color Corp.) from Paul Counterman NYSDEC Bureau of Hazardous Waste and Facility Management, regarding Preliminary Draft Part 373 Permit.
- New York State Department of Environmental Conservation (NYSDEC), 1999. New York Codes, Rules, and Regulations, Title 6, Part 703 Surface Water and Groundwater Quality Standards and Groundwater Effluent Limitations. Amended August 1999.
- New York State Department of Health (NYSDOH), 2009. Generic Community Air Monitoring Plan. December 2009.
- New York State Department of Environmental Conservation, 2010, “Final DER-10 Technical Guidance for Site Investigation and Remediation”, May.
- New York State Department of Health, Center for Environmental Health, Bureau of Environmental Exposure Investigation, 2017, “Guidance for Evaluating Soil Vapor Intrusion in the State of New York, Public Comment Draft”, May.

**Remedial Action Work Plan
Area E
Former Buffalo Color Corporation**

FIGURES

MEDAILLE COLLEGE ATHLETIC COMPLEX

427 Elk Street

City of Buffalo, County of Erie, New York 14210

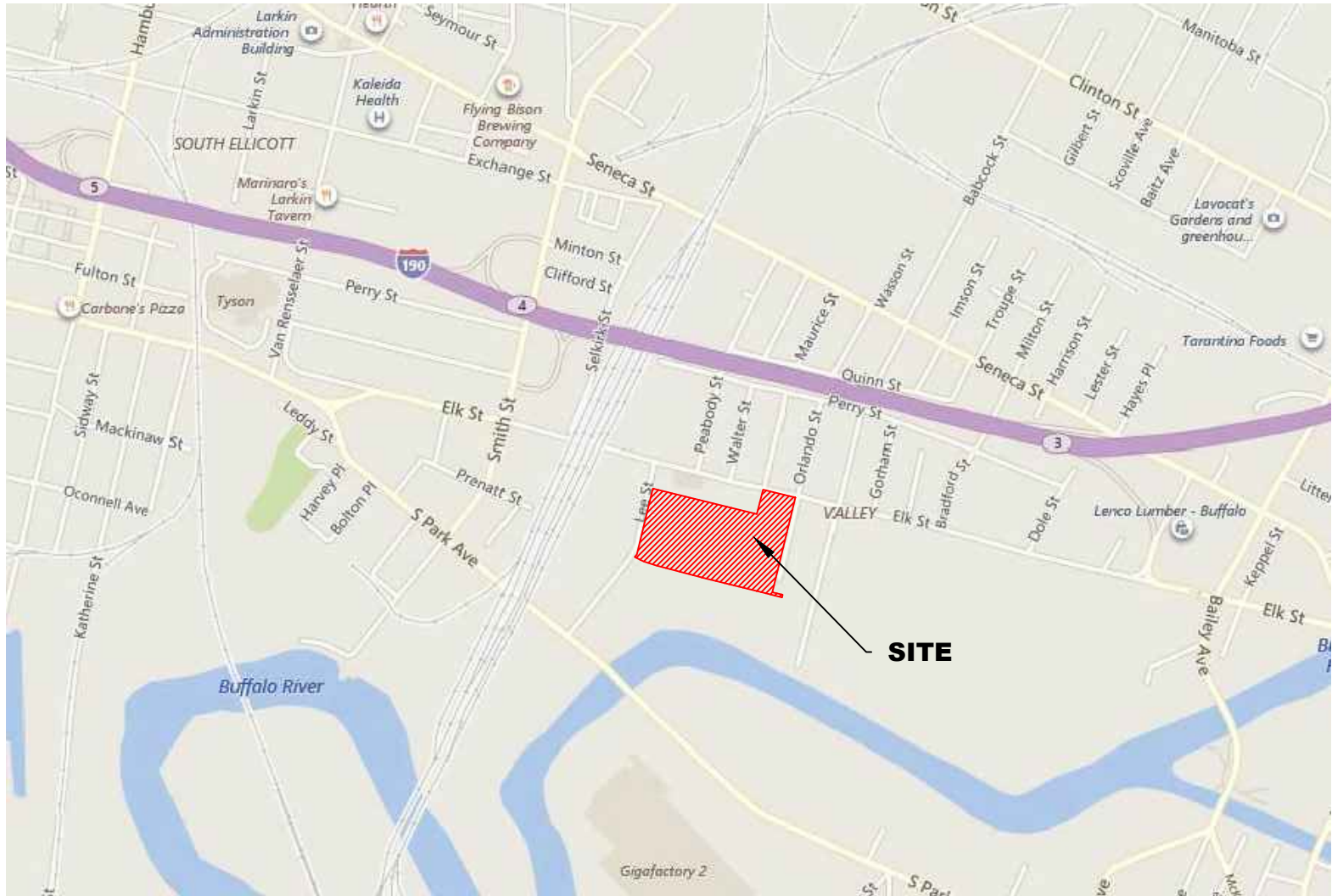

SITE LOCATION MAP
NTS



AERIAL LOCATION MAP
NTS



PROJECT LAYOUT
1" = 150'

DRAWING INDEX	
SHEET TITLE	SHEET NO.
COVER SHEET	1 OF 8
EXISTING CONDITIONS PLAN	2 OF 8
PROJECT SITE LAYOUT PLAN	3 OF 8
GRADING AND DRAINAGE PLAN	4 OF 8
EROSION AND SEDIMENT CONTROL PLAN	5 OF 8
TYPICAL SECTIONS	6 OF 8
DETAILS - PAVING AND DRAINAGE	7 OF 8
DETAILS - EROSION AND SEDIMENT CONTROL	8 OF 8

NO.	DATE	REVISIONS
0	08-17-18	ISSUED FOR AGENCY REVIEW - NOT FOR CONSTRUCTION
1		
2		
3		
4		
5		
6		
7		
8		

UNAUTHORIZED ALTERATION OR ADDITION TO THESE PLANS IS A VIOLATION OF SECTION 7209, PROVISION 2 OF THE NEW YORK STATE EDUCATION LAW.

Advanced Design Group
PROFESSIONAL ENGINEERING & LAND SURVEYING, P.C.
761 CAVALIER STREET
BUFFALO, NY 14203
PHONE: (716) 754-2256
FAX: (716) 754-4252

COVER SHEET

Medaille College Athletic Complex
427 Elk Street
City of Buffalo, Erie County, New York 14210
South Buffalo Development, LLC
333 Ganson Street
Buffalo, NY 14203
Project Contact: Advanced Design Group (716) 754-2256

DATE: 7-16-18 PROJECT NO.: 18-787 SHEET: 1 of 8

SCALE: AS NOTED

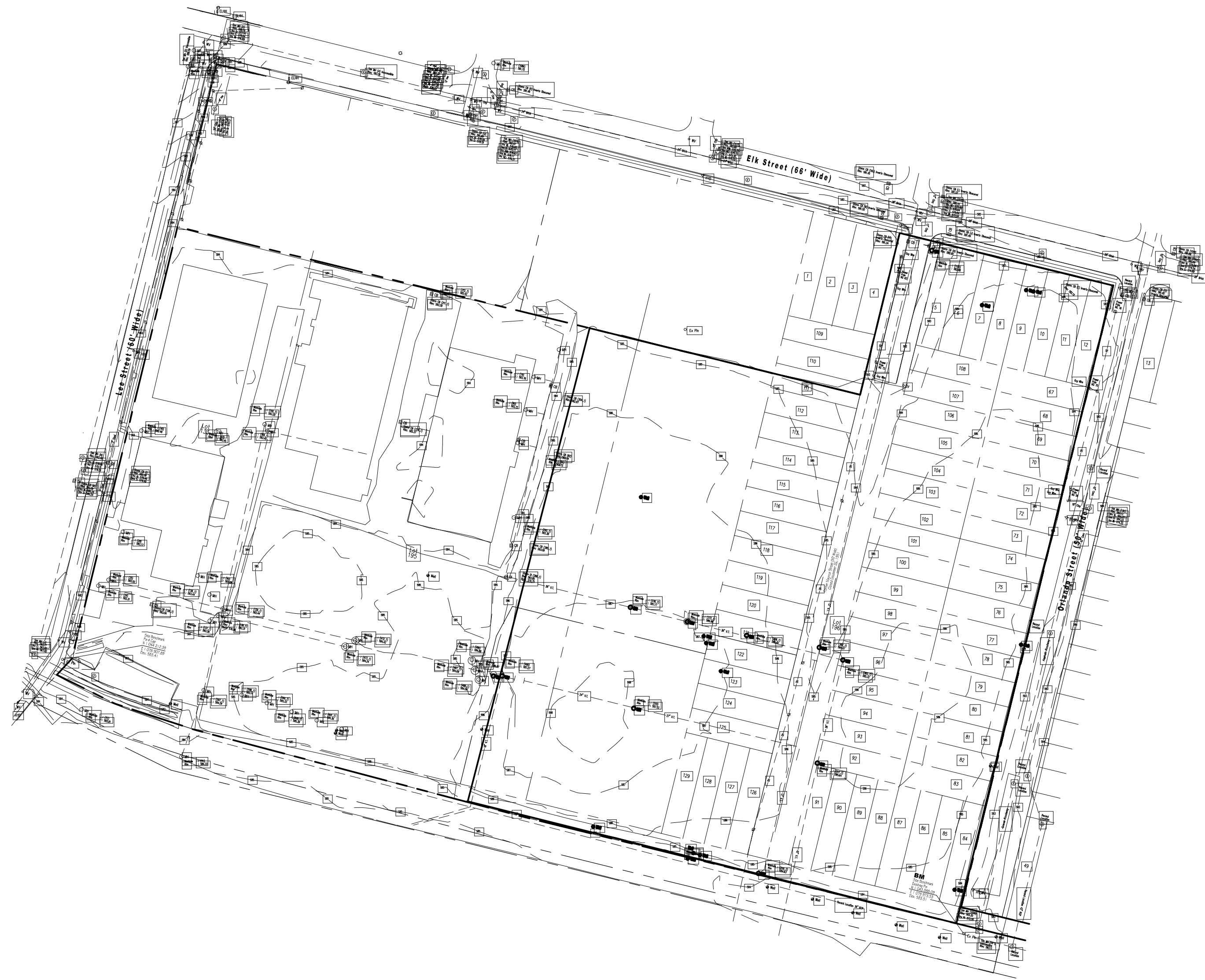

EXISTING CONDITIONS PLAN
SCALE: 1" = 100'-0"



EXISTING CONDITIONS W/ AERIAL
SCALE: 1" = 100'-0"

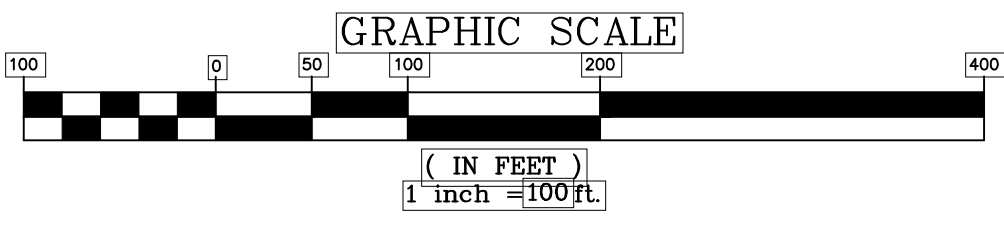

Abbreviations		Symbols		Line Styles	
Ex - Existing	Sanitary Manhole	SA	Sanitary Sewer	SA	Sanitary Sewer
EW - Electric	Storm Sewer	SS	Storm Sewer	SS	Storm Sewer
WC - Water	Water Main	WM	Water Main	WM	Water Main
GS - Gas	Gas Line	GL	Gas Line	GL	Gas Line
...

MAP REFERENCE
MAP SHOWING TOPOGRAPHIC SURVEY OF ROADS AND RIGHT OF WAY FOR LEE STREET, ELK STREET, ORLANDO STREET & THE RAILROAD RIGHT OF WAY SURROUNDING TAX PARCEL ID: 122.12-1-9-9.11, PREPARED BY NIAGARA BOUNDARY AND MAPPING SERVICES; DATED JULY 23, 2018, JOB NO. 6941-ELK 2018.

EXISTING CONDITIONS PLAN
Medaille College Athletic Complex
427 Elk Street
City of Buffalo, Erie County, New York 14210
South Buffalo Development, LLC
333 Ganson Street
Buffalo, NY 14203
Project Contact: Advanced Design Group (716) 754-2256

NO.	DATE	REVISIONS
8		
7		
6		
5		
4		
3		
2		
1	08-17-18	ISSUED FOR AGENCY REVIEW - NOT FOR CONSTRUCTION

UNAUTHORIZED ALTERATION OR ADDITION TO THESE PLANS IS A VIOLATION OF SECTION 7209, PROVISION 2 OF THE NEW YORK STATE EDUCATION LAW.

Prepared by:
ADVANCED DESIGN GROUP
PROFESSIONAL ENGINEERING & LAND SURVEYING, PC
781 CAYUGA STREET
BUFFALO, NY 14203
PHONE: (716) 754-2256
FAX: (716) 754-4252



LEGEND

EXISTING	PROPOSED	DESCRIPTION
---	---	NTS
---	---	E, T, C
---	---	OVERHEAD ELEC/TELE
---	---	W
---	---	S
---	---	FM
---	---	ST
---	---	CONTOUR
---	---	SPOT ELEVATIONS
---	---	FENCE
---	---	PROPERTY/ROW LINE
---	---	EASEMENT
---	---	UTILITY POLE
---	---	LIGHT
---	---	ELECTRIC MANHOLE
---	---	SANITARY MANHOLE
---	---	STORM MANHOLE
---	---	CATCHBASIN (ROADWAY)
---	---	REAR YARD DRAIN (INLET)
---	---	HYDRANT
---	---	SIGN
---	---	GRADE TO DRAIN
---	---	WATER VALVE
---	---	TEST PIT
---	---	TO BE REMOVED
---	---	BENCH MARK

CONSTRUCTION NOTES

- UTILITIES AS SHOWN ON THESE DRAWINGS ARE PLOTTED FROM FIELD EVIDENCE AND INFORMATION SUPPLIED BY VARIOUS UTILITY AGENCIES. THE INFORMATION IS NOT TO BE RELIED ON AS BEING EXACT OR COMPLETE. ADVANCED DESIGN GROUP P.E. & L.S., P.C. ASSUMES NO RESPONSIBILITY AS TO THE ACCURACY OF THE UNDERGROUND UTILITIES. CONTRACTORS MUST CALL U.P.O. AT LEAST TWO WORKING DAYS PRIOR TO ANY EXCAVATION 1-800-982-7982. THE CONTRACTOR SHALL MAKE EXPLORATION EXCAVATIONS TO LOCATE EXISTING UNDERGROUND UTILITIES SUFFICIENTLY AHEAD OF CONSTRUCTION TO PERMIT REVISIONS AS REQUIRED TO MEET EXISTING CONDITIONS. IT SHALL BE THE RESPONSIBILITY OF THE CONTRACTOR TO RELOCATE ALL EXISTING UTILITIES WHICH CONFLICT WITH THE PROPOSED IMPROVEMENTS SHOWN ON THE PLANS.
- ALL AREAS THAT ARE NOT PAVED OR LANDSCAPED MUST BE PERMANENTLY VEGETATED WITH A MINIMUM OF 4" OF TOPSOIL AND GRASS SEED MAINTAINED AS LAWN.
- TOPSOIL REQUIRED FOR THE ESTABLISHMENT OF VEGETATION SHALL BE STOCKPILED IN AMOUNT NECESSARY TO COMPLETE FINISHED GRADING OF ALL EXPOSED AREAS.
- AREAS TO BE FILLED SHALL BE CLEARED, GRUBBED, AND STRIPPED OF TOPSOIL TO REMOVE TREES, VEGETATION, ROOTS OR OTHER OBJECTIONABLE MATERIAL.
- ALL FILLS SHALL BE COMPACTED AS REQUIRED TO REDUCE EROSION, SURFACE, SETTLEMENT, SUBSIDENCE OR OTHER RELATED PROBLEMS. FILL INTENDED TO SUPPORT BUILDINGS, STRUCTURES AND CONDUITS, ETC. SHALL BE COMPACTED IN ACCORDANCE WITH LOCAL REQUIREMENTS OR CODES. FILL SHALL NOT BE PLACED ON SATURATED OR FROZEN SURFACES. ALL FILL TO BE PLACED AND COMPACTED IN LAYERS NOT TO EXCEED 6 INCHES IN THICKNESS.
- FILL MATERIAL SHALL BE FREE OF FROZEN PARTICLES, BRUSH, ROOTS, SOIL, OR OTHER FOREIGN OR OTHER OBJECTIONABLE MATERIALS THAT WOULD INTERFERE WITH OR PREVENT CONSTRUCTION OF SATISFACTORY FILLS. FROZEN MATERIALS OR SOFT, MUCKY OR HIGHLY COMPRESSIBLE MATERIALS SHALL NOT BE INCORPORATED IN FILLS.
- ALL GRADED AREAS SHALL BE PERMANENTLY STABILIZED IMMEDIATELY FOLLOWING FINISHED GRADING.
- SELECT BACKFILL IS REQUIRED FOR ALL UTILITIES (ELECT., STORM) THAT CROSS THROUGH AND WITHIN FIVE (5) FEET OF ANY PAVEMENT AREA.
- ALL PROPOSED ELEVATIONS SHOWN HEREON ARE FINISHED GRADE ELEVATIONS.
- ALL CONSTRUCTION SHALL BE IN ACCORDANCE WITH CITY OF BUFFALO CONSTRUCTION SPECIFICATIONS, RULES AND DETAILS.
- THE CONTRACTOR SHALL BE RESPONSIBLE TO SECURE ALL PERMITS AND PROVIDE ALL BONDS REQUIRED FOR THIS WORK INCLUDING, BUT NOT LIMITED TO, SITE CONSTRUCTION.
- ALL SIGNAGE SHALL BE IN CONFORMANCE WITH THE CITY OF BUFFALO'S REGULATIONS. ALL SIGNAGE TO BE APPROVED BY THE CITY OF BUFFALO PRIOR TO INSTALLATION.
- EXTERIOR LIGHTING FOR PROPOSED BUILDING TO BE DARK SKY FRIENDLY LIGHTING. LIGHTS TO BE LOCATED AT BUILDING ENTRANCES FOR SAFETY.
- CONTRACTOR TO REFER TO GEOTECHNICAL REPORT, IF AVAILABLE, FOR ALL SITE WORK, OR PROVIDE TEST PITS; SUBMISSION OF A BID INDICATES THAT THE SITE CONTRACTOR AND THE GENERAL CONTRACTOR HAVE EXCEPTED THE FINDINGS OF THE REPORT/TEST PITS AND WILL PROVIDE ALL WORK IN CONFORMANCE WITH ITS RECOMMENDATIONS.
- PROPOSED VAN ACCESSIBLE HANDICAP PARKING SPACE (9 FT. X 19 FT.) WITH HANDICAP PARKING SIGN (SEE DETAIL) AND PAVEMENT MARKINGS (TYPICAL OF 5 SPACES).
- ALL STANDARD PARKING SPACES ARE TO BE 9 FT. X 19 FT.
- 6" UPRIGHT CURBING - SEE CURBING DETAIL.
- LIMIT OF PROPOSED 6" CURBING - CURBING TO TAPER TO MATCH ADJACENT GRADE.
- SNOW STORAGE AREA (TYP.)
- APPROXIMATE LOCATION PROPOSED EDGE OF PAVEMENT - NO CURBING - TYP.
- APPROXIMATE LOCATION PROPOSED UNDERGROUND PRIVATE UTILITY SERVICE (ELECTRIC/TELEPHONE/CABLE). INSTALLATION TO BE COORDINATED WITH UTILITY OWNER. FINAL DESIGN TO BE INCLUDED WITH FIELD HOUSE FINAL PLANS.
- 22.5 FT. CONCRETE SIDEWALK - SEE DETAIL.
- CONTRACTOR TO COORDINATE WITH PRIVATE UTILITY OWNERS PRIOR TO START OF CONSTRUCTION AND NOTIFY DESIGN ENGINEER OF ANY UTILITY RE-LOCATIONS THAT MAY BE NECESSARY AND HAVE AN AFFECT ON THE APPROVED DESIGN (EX: POLES AND GUY WIRES, BURIED SERVICES, ETC).
- PROPOSED 10' ASPHALT ACCESS DRIVE.
- 390± L.F. 3" BLACK VINYL COATED CHAIN LINK FENCE W/IN CURB OF ATHLETIC FIELD. CONTRACTOR TO COORDINATE INSTALLATION WITH ATHLETIC FIELD MANUFACTURER.
- APPROXIMATE LOCATION OF FUTURE SANITARY SERVICE. FINAL DESIGN TO BE INCLUDED WITH FIELD HOUSE FINAL PLANS. SANITARY SEWER SERVICE INSTALLATION TO BE IN CONFORMANCE WITH THE BUFFALO SEWER AUTHORITY'S REGULATIONS AND REQUIREMENTS. STANDARD WORK ZONE TRAFFIC CONTROL PLANS FOR SHOULDER AND LANE CLOSURES TO BE UTILIZED.
- APPROXIMATE LOCATION OF FUTURE WATER SERVICE FOR DOMESTIC USE AND FIRE PROTECTION. FINAL DESIGN TO BE INCLUDED WITH FIELD HOUSE FINAL PLANS - NEW WATER METER AND NEW BACKFLOW PREVENTION DEVICE LOCATED INSIDE BUILDING LOCATION AND CONNECTION TO BE COORDINATED WITH THE CITY OF BUFFALO AND E.C.W.A. WATER SERVICE INSTALLATION TO BE IN CONFORMANCE WITH THE CITY OF BUFFALO AND E.C.W.A. REGULATIONS AND REQUIREMENTS. STANDARD WORK ZONE TRAFFIC CONTROL PLANS FOR SHOULDER AND LANE CLOSURES TO BE UTILIZED.
- EXISTING APRON TO BE UTILIZED FOR CONSTRUCTION ACCESS. ACCESS TO BE REMOVED AND AREA RESTORED TO GRASS UPON COMPLETION OF CONSTRUCTION.
- ROOF LEADERS OF PROPOSED BUILDING TO DISCHARGE TO DRY DETENTION AREA.
- DRY DETENTION AREA TO BE PLANTED WITH PERMANENT VEGETATION SEED MIXTURE (SEE SHEET 8 OF 8) AND MAINTAINED AT A 6"± HEIGHT.
- PROPOSED 5' X 6" CONCRETE PAD (TYP. OF 2) - SEE ARCHITECTURAL PLANS AND CONCRETE WALK AND PAD DETAIL.
- APPROX. LOCATION PROPOSED SITE LIGHTING POLE AND STANDARD (TYP. OF 4).
- APPROX. LOCATION PROPOSED BUILDING MOUNTED AREA LIGHT (TYP. OF 4).
- APPROX. LOCATION PROPOSED ATHLETIC FIELD LIGHT POLE AND STANDARD (TYP. OF 4).
- CONCRETE WALK CURB RAMP - SEE DETAIL.
- EXISTING CONCRETE SIDEWALK TO REMAIN. CONTRACTOR TO REPAIR ANY PROJECT RELATED DAMAGE.
- STANDARD DUTY ASPHALT PAVEMENT - SEE DETAIL.
- HEAVY DUTY ASPHALT PAVEMENT - SEE DETAIL.
- SIDEWALK AT DRIVEWAY CROSSING SHALL HAVE A MINIMUM THICKNESS OF 6" AND INCLUDE FIBER REINFORCEMENT WITH 3" OF TOP COVER.
- PROPOSED DOUBLE SWING GATE W/ 12' WIDE OPENING.
- CONCRETE DUMPSTER PAD AREA. PAD SEE LOCATION AND SPECIFICATIONS TO BE DETERMINED BY OWNER, CONTRACTOR AND REFUSE COMPANY PRIOR TO CONSTRUCTION. DUMPSTER AREA TO BE ENCLOSED WITH 6" CHAIN LINK GATED FENCE WITH PRIVACY SLATS.
- PROPOSED SLIDING GATE W/ 12' WIDE OPENING.
- APPROXIMATE LOCATION UNDERGROUND ELECTRICAL FOR SITE LIGHTING, PRESS BOX AND SCOREBOARD. CONTRACTOR TO COORDINATE FINAL DESIGN WITH OWNER, LIGHTING AND SCOREBOARD MANUFACTURERS.
- PROPOSED CONCRETE PAD FOR BLEACHERS AND PRESS BOX. SEE ARCHITECTURAL PLANS FOR SEATING AND PRESS BOX LAYOUT.
- 515± L.F. (TOTAL) 6" BLACK VINYL COATED CHAIN LINK FENCE - SEE DETAIL.
- 1,690± L.F. (TOTAL) 4" BLACK VINYL COATED CHAIN LINK FENCE - SEE DETAIL.
- EXISTING MANHOLE. RIM TO BE ADJUSTED TO 4" BELOW FINISH GRADE (TYP.).
- EXISTING MANHOLE. RIM TO BE ADJUSTED TO FINISH GRADE.
- EXISTING MONITORING WELL. INSTALL FLUSH MOUNT WELL CAP AND ADJUST RIM ELEVATION TO BOTTOM OF TURF ELEVATION.
- EXISTING MONITORING WELL WITHIN PROPOSED DRY DETENTION POND. ADJUST RIM TO PROPOSED GRADE AND INSTALL LINER BOOT.
- PROPOSED FIELD HOUSE DESIGN, PERMITTING AND CONSTRUCTION TO BE INCLUDED IN FUTURE PROJECT AND APPROVALS. FIELD HOUSE CONSTRUCTION IS NOT PART OF THIS PROJECT.
- CONCRETE BUMPER BLOCK - SEE DETAIL.

NOTE: SEE SHEET 6 OF 8 FOR TYPICAL SECTIONS "A-A" THRU "F-F"

[Pattern]	STANDARD DUTY PAVEMENT
[Pattern]	HEAVY DUTY PAVEMENT

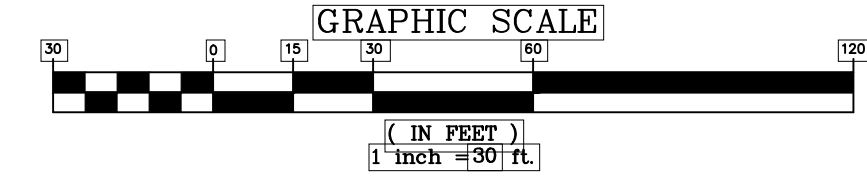

PROJECT SITE LAYOUT PLAN

Medaille College Athletic Complex
 City of Buffalo, Erie County, New York 14210
 South Buffalo Development, LLC
 333 Ganson Street
 Buffalo, NY 14203
 Project Contact: Advanced Design Group (716) 754-2256

UNAUTHORIZED ALTERATION OR ADDITION TO THESE PLANS IS A VIOLATION OF SECTION 7209, PROVISION 2 OF THE NEW YORK STATE EDUCATION LAW.

Prepared by:

ADVANCED DESIGN GROUP
 PROFESSIONAL ENGINEERING & LAND SURVEYING, P.C.
 781 Cayuga Street
 Buffalo, NY 14203
 Phone: (716) 754-2256
 Fax: (716) 754-4252

NO.	DATE	ISSUED FOR AGENCY REVIEW - NOT FOR CONSTRUCTION REVISIONS
8		
7		
6		
5		
4		
3		
2		
1	08-17-18	

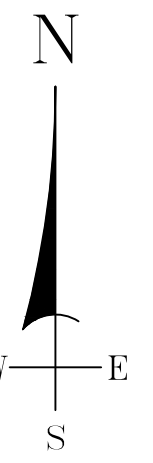

XX STORM STRUCTURE TABLE

1	251 L.F. 8" PERF. HDPE @ S=0.2% W INV=584.21 E INV=583.71 (90° 8" HDPE ELBOW)
2	386 L.F. 8" PERF. HDPE @ S=0.2% S INV=583.71 N INV=582.94
3	386 L.F. 8" PERF. HDPE @ S=0.2% S INV=584.21 N INV=583.44 (90° 8" HDPE ELBOW)
4	251 L.F. 8" PERF. HDPE @ S=0.2% W INV=583.44 E INV=582.94
5	8" X 8" X 8" HDPE TEE INV=582.94
6	93L.F. 8" HDPE @ S=0.2% W/ WATERTIGHT JOINTS
7	CATCH BASIN RIM=584.90 N INV=581.94 (15")
8	150 L.F. 15" HDPE @ S=0.2% W/ WATERTIGHT JOINTS
9	CATCH BASIN RIM=584.90 W INV=582.75 (6") S INV=581.64 (15") N INV=581.64 (18")
10	132 L.F. 18" HDPE @ S=0.2% W/ WATERTIGHT JOINTS
11	CATCH BASIN RIM=584.95 S INV=581.38 (18") NE INV=581.38 (24")
12	28 L.F. 24" HDPE @ S=0.2% W/ WATERTIGHT JOINTS
13	PIPE OUTLET W/ END SECTION AND ROCK OUTLET PROTECTION INV=581.32 (24")
14	ROOF LEADER DISCHARGE 18 L.F. 10" PVC SDR-35 @ S=1.0% MIN. W/ WATERTIGHT JOINTS
15	PIPE OUTLET W/ END SECTION AND ROCK OUTLET PROTECTION INV=581.30 (10")
16	ROOF LEADER DISCHARGE 30 L.F. 10" PVC SDR-35 @ S=1.0% MIN. W/ WATERTIGHT JOINTS
17	PIPE OUTLET W/ END SECTION AND ROCK OUTLET PROTECTION INV=581.30 (10")
18	DRY DETENTION POND OUTLET STRUCTURE CATCH BASIN W/ TRAP AND CLEANOUT RIM=584.10 S INV=580.85 (6" ORIFICE W/ TRASH RACK) N INV=579.30 (12" PVC SDR-35)
19	50 L.F. 12" PVC SDR-35 @ S=1.0% MIN. W/ WATERTIGHT JOINTS
20	CONNECTION TO EXISTING 28" BRICK COMBINED SEWER PER BUFFALO SEWER AUTHORITY REQUIREMENTS

LEGEND

EXISTING	PROPOSED	GAS
---	---	---
---	---	UNDERGROUND ELEC/TELE/CABLE
---	---	OVERHEAD ELEC/TELE
---	---	WATER
---	---	SANITARY SEWER
---	---	SANITARY FORCE MAIN
---	---	STORM SEWER
---	---	CONTOUR
---	---	SPOT ELEVATIONS
---	---	FENCE
---	---	PROPERTY/ROW LINE
---	---	EASEMENT
---	---	UTILITY POLE
---	---	LIGHT
---	---	ELECTRIC MANHOLE
---	---	SANITARY MANHOLE
---	---	STORM MANHOLE
---	---	CATCHBASIN (ROADWAY)
---	---	REAR YARD DRAIN (INLET)
---	---	HYDRANT
---	---	SIGN
---	---	GRADE TO DRAIN
---	---	WATER VALVE
---	---	TEST PIT
---	---	TO BE REMOVED
---	---	BENCH MARK

NOTE: SEE SHEET 6 OF 8 FOR TYPICAL SECTIONS "A-A" THRU "F-F"

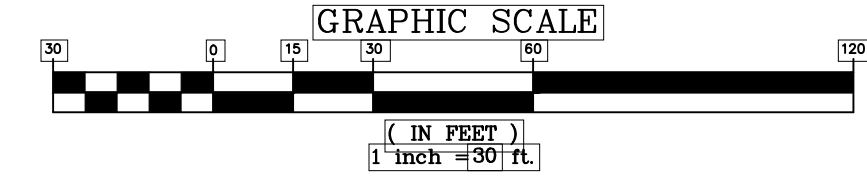
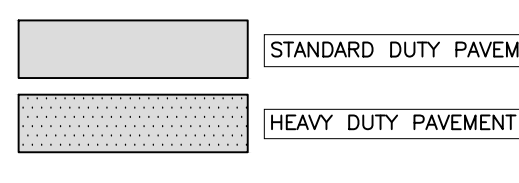

UNAUTHORIZED ALTERATION OR ADDITION TO THESE PLANS IS A VIOLATION OF SECTION 7209, PROVISION 2 OF THE NEW YORK STATE EDUCATION LAW.	
8	
7	
6	
5	
4	
3	
2	
1	
0	08-17-18
	ISSUED FOR AGENCY REVIEW - NOT FOR CONSTRUCTION
	NO.
	DATE
	REVISIONS
Prepared by: 	
Advanced Design Group 781 Cayuga Street Buffalo, NY 14203 Phone: (716) 754-2256 Fax: (716) 754-4252	
GRADING AND DRAINAGE PLAN	
Medaille College Athletic Complex	
City of Buffalo, Erie County, New York 14210 South Buffalo Development, LLC 333 Ganson Street Buffalo, NY 14203	
Project Contact: Advanced Design Group (716) 754-2256	
Scale: AS NOTED	Date: 7-16-18
	Project No.: 18-4787
	Sheet: 4 of 8

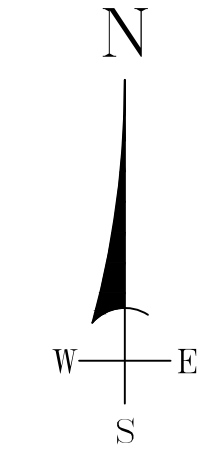

LEGEND

EXISTING	PROPOSED	DESCRIPTION
---	---	GAS
---	---	UNDERGROUND ELEC./TELE./CABLE
---	---	OVERHEAD ELEC./TELE.
---	---	WATER
---	---	SANITARY SEWER
---	---	SANITARY FORCE MAIN
---	---	STORM SEWER
---	---	CONTOUR
---	---	SPOT ELEVATIONS
---	---	FENCE
---	---	PROPERTY/ROW LINE
---	---	EASEMENT
---	---	UTILITY POLE
---	---	LIGHT
---	---	ELECTRIC MANHOLE
---	---	SANITARY MANHOLE
---	---	STORM MANHOLE
---	---	CATCHBASIN (ROADWAY)
---	---	REAR YARD DRAIN (INLET)
---	---	HYDRANT
---	---	SIGN
---	---	GRADE TO DRAIN
---	---	WATER VALVE
---	---	TEST PIT
---	---	TO BE REMOVED
---	---	BENCH MARK
---	---	SILT FENCE/FIBER ROLL
---	---	CONSTRUCTION ENTRANCE
---	---	PERMANENT VEGETATION
---	---	TEMPORARY VEGETATION
---	---	INLET PROTECTION

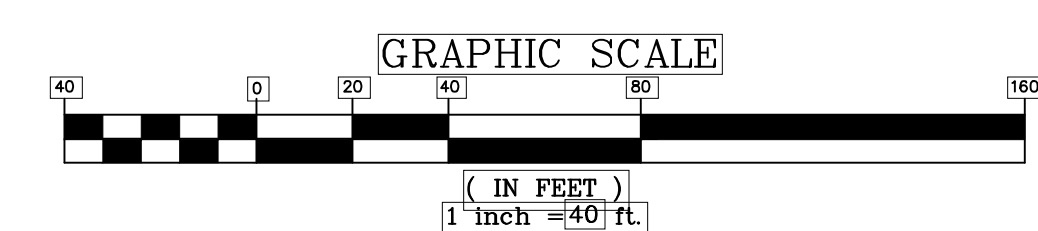

EROSION AND SEDIMENT CONTROL PLAN
SCALE: 1" = 30'-0"

EROSION AND SEDIMENT CONTROL PLAN
Medaille College Athletic Complex
427 Elk Street
City of Buffalo, Erie County, New York 14210
South Buffalo Development, LLC
333 Ganson Street
Buffalo, NY 14203
Project Contact: Advanced Design Group (716) 754-2256

UNAUTHORIZED ALTERATION OR ADDITION TO THESE PLANS IS A VIOLATION OF SECTION 7209, PROVISION 2 OF THE NEW YORK STATE EDUCATION LAW.

Prepared by:
ADVANCED DESIGN GROUP
PROFESSIONAL ENGINEERING & LAND SURVEYING, P.C.
781 Cayuga Street
Buffalo, NY 14203
Phone: (716) 754-2256
Fax: (716) 754-4252

STATE OF NEW YORK
JAMES J. COUGHLIN
LICENSED PROFESSIONAL ENGINEER

NO.	DATE	ISSUED FOR AGENCY REVIEW - NOT FOR CONSTRUCTION REVISIONS
8		
7		
6		
5		
4		
3		
2		
1	08-17-18	

Scale: AS NOTED
Date: 7-16-18
Project no.: 18-4787
Sheet: 5 of 8

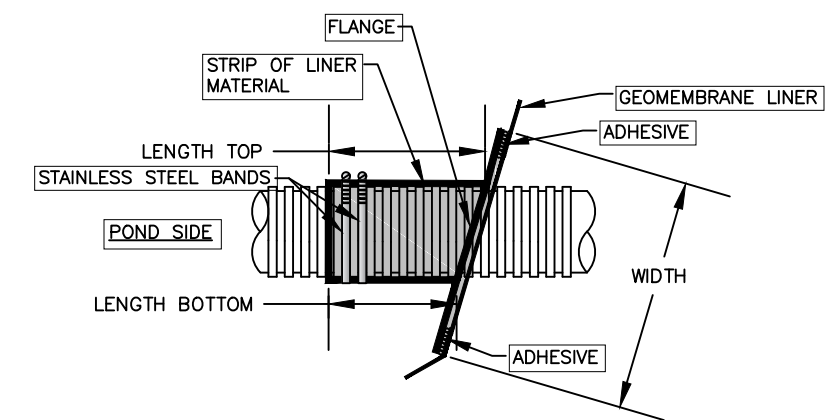
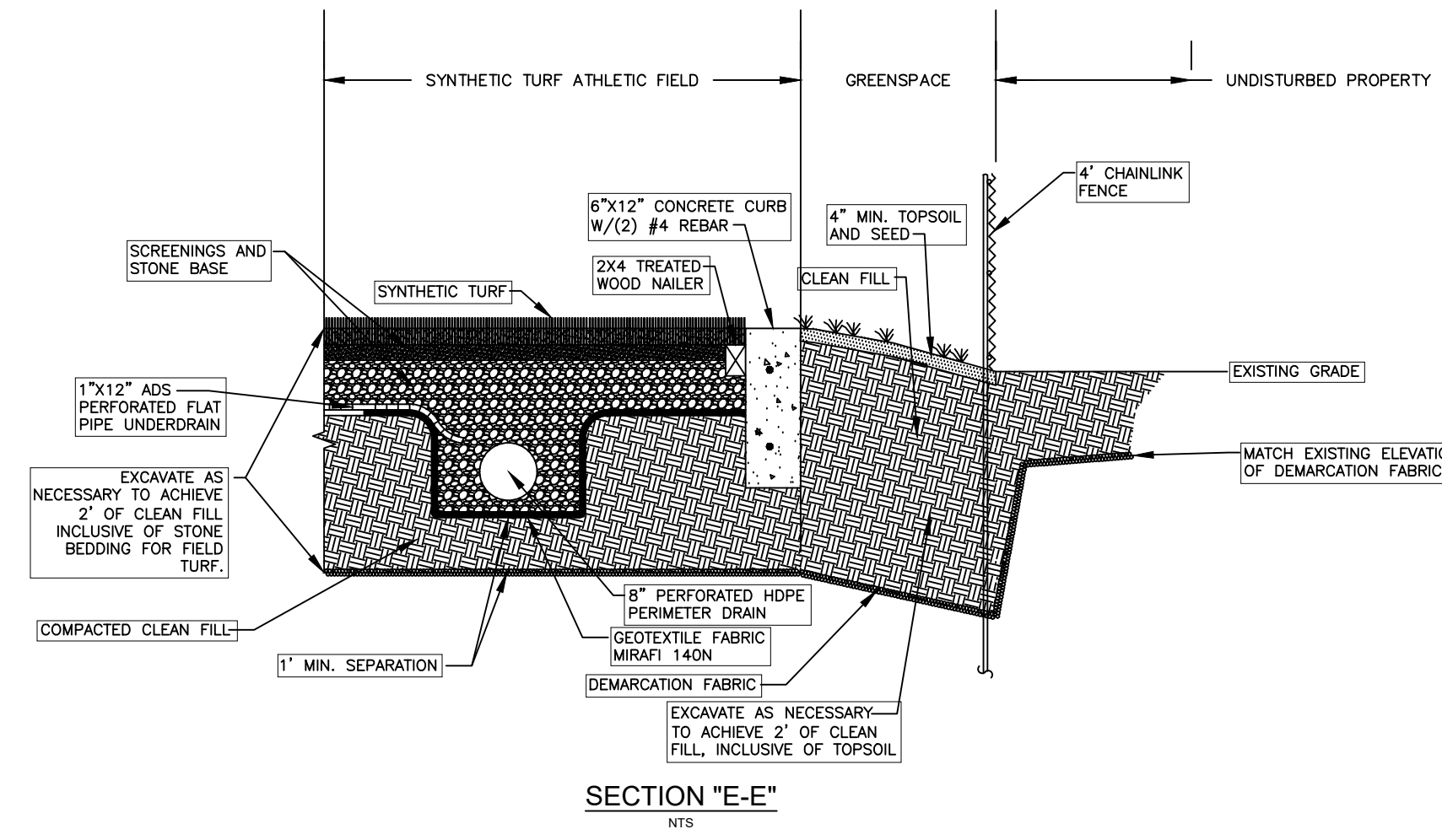
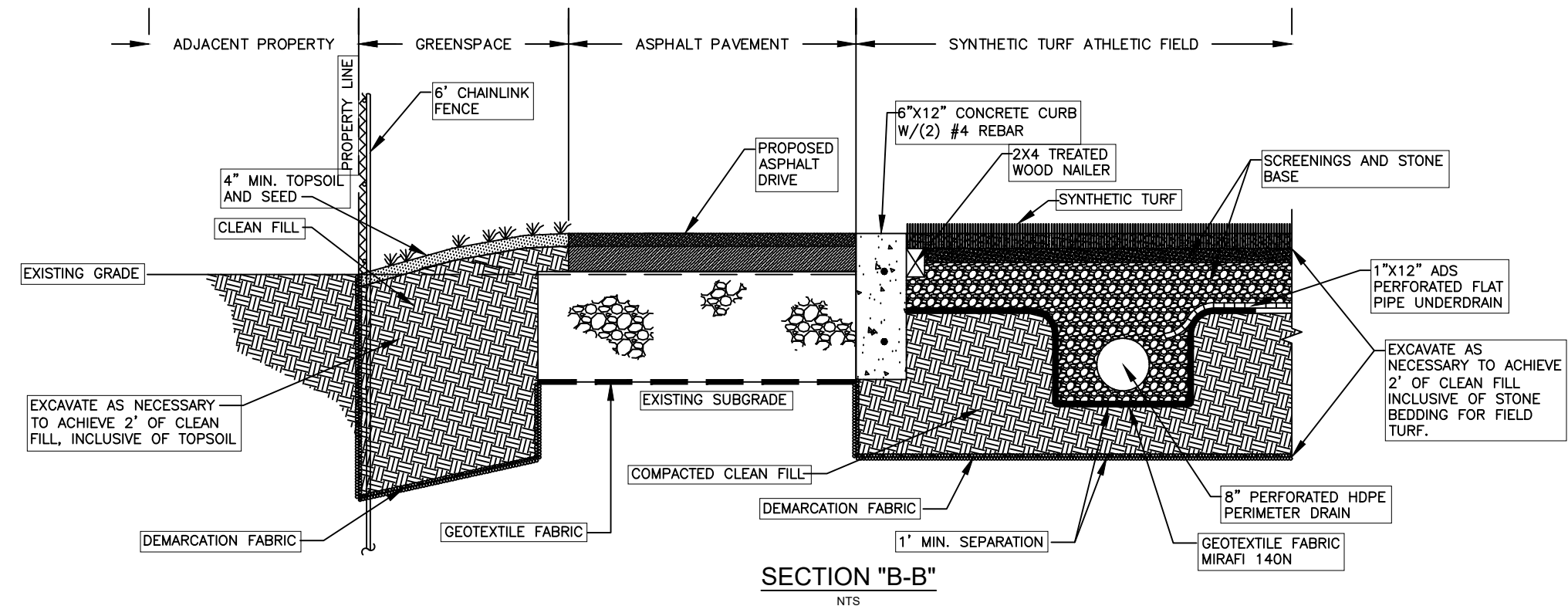
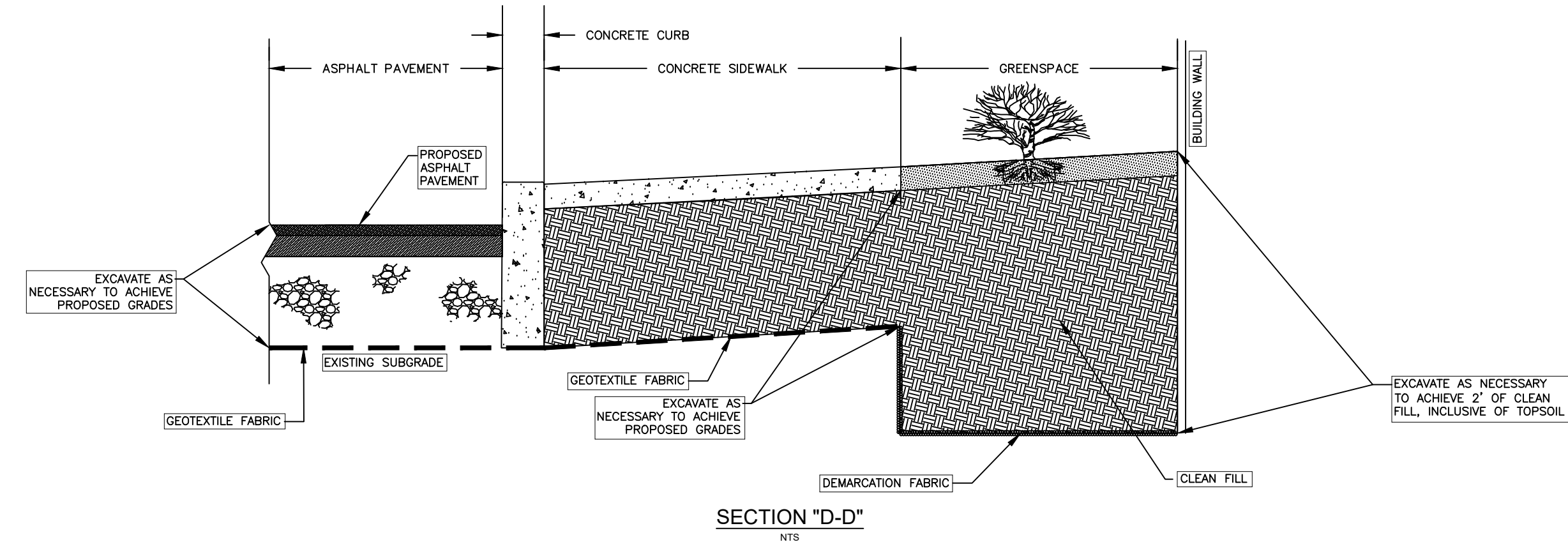
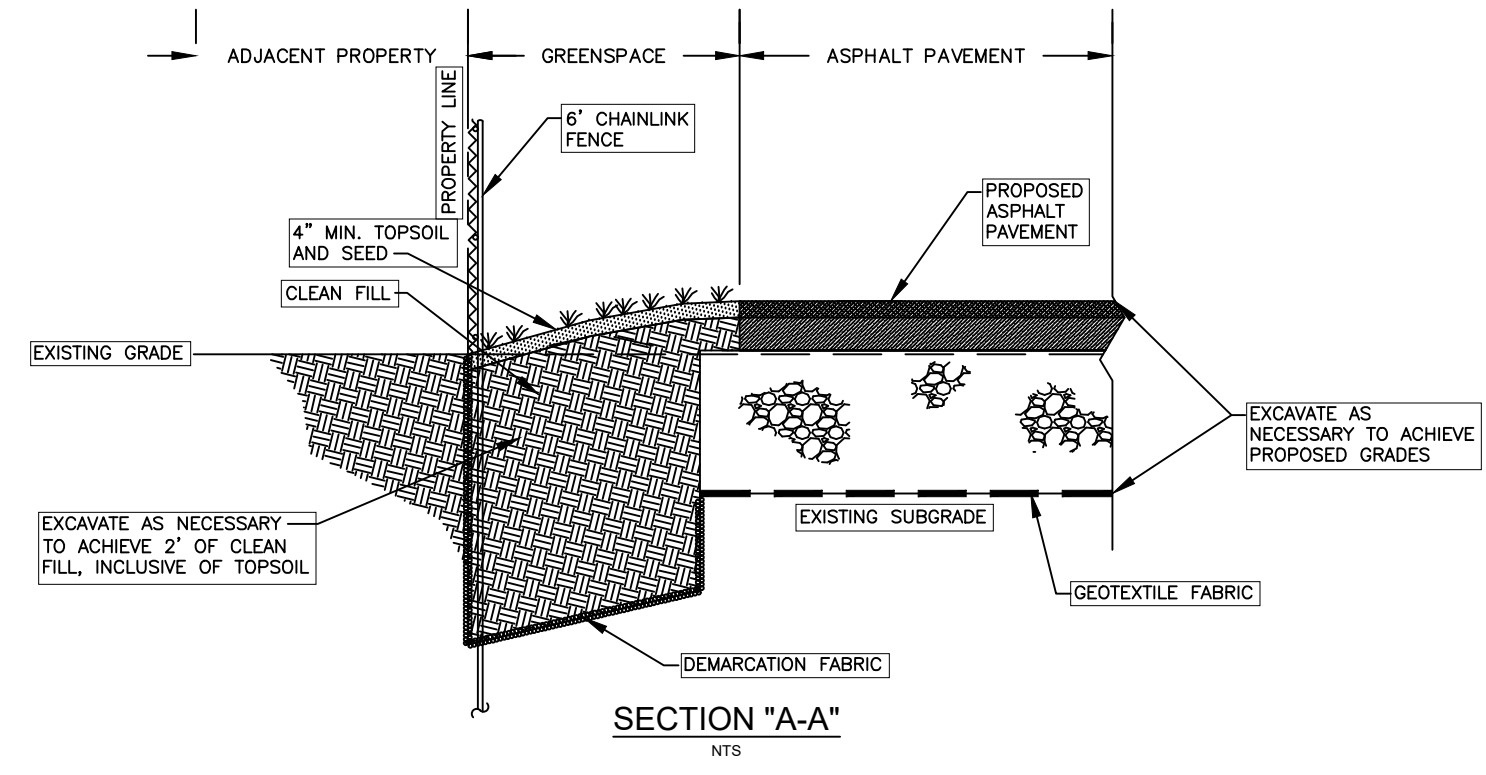

DIA. OF PIPE	LENGTH TOP	LENGTH BOTTOM	WIDTH
10"	48"	18"	46" SO.
12"	54"	18"	50" SO.
24"	60"	18"	60" SO.

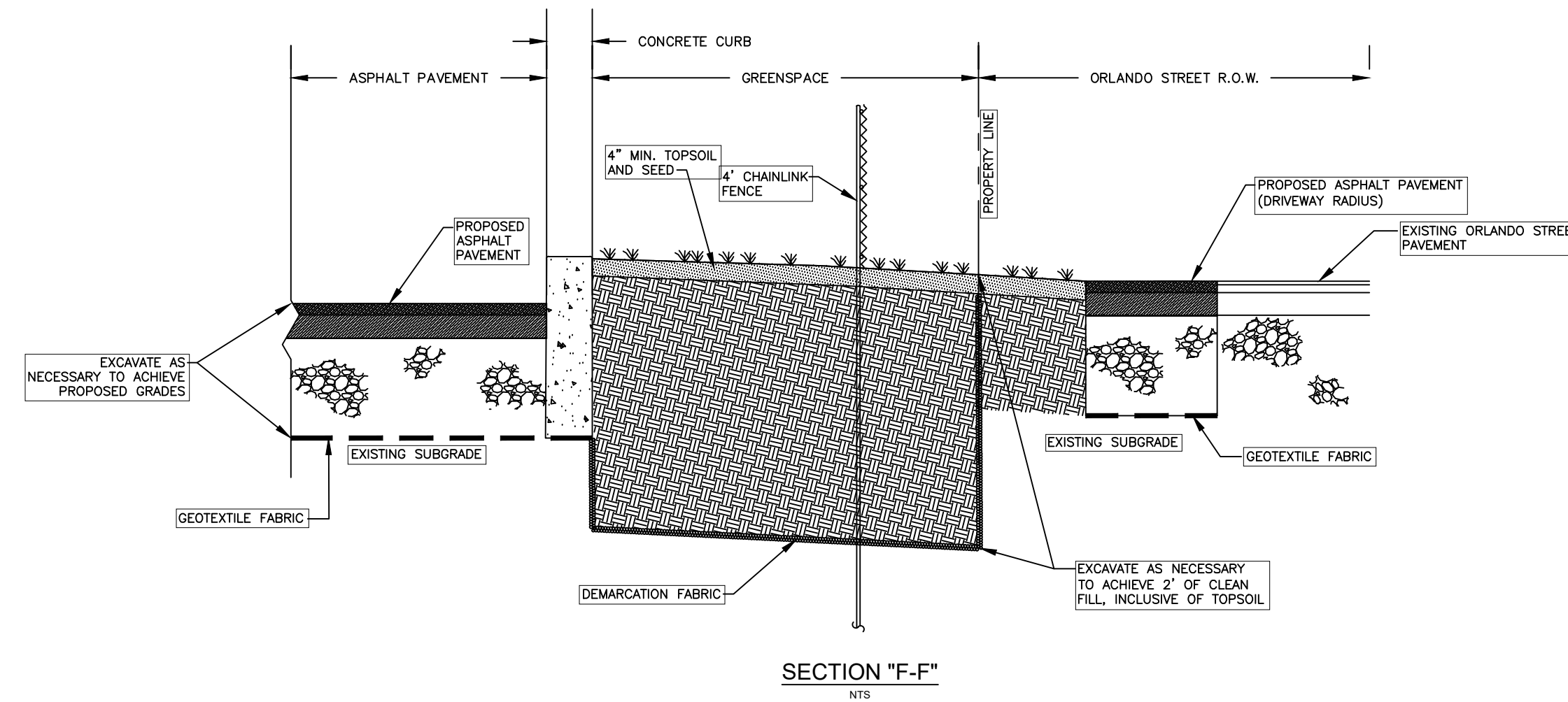
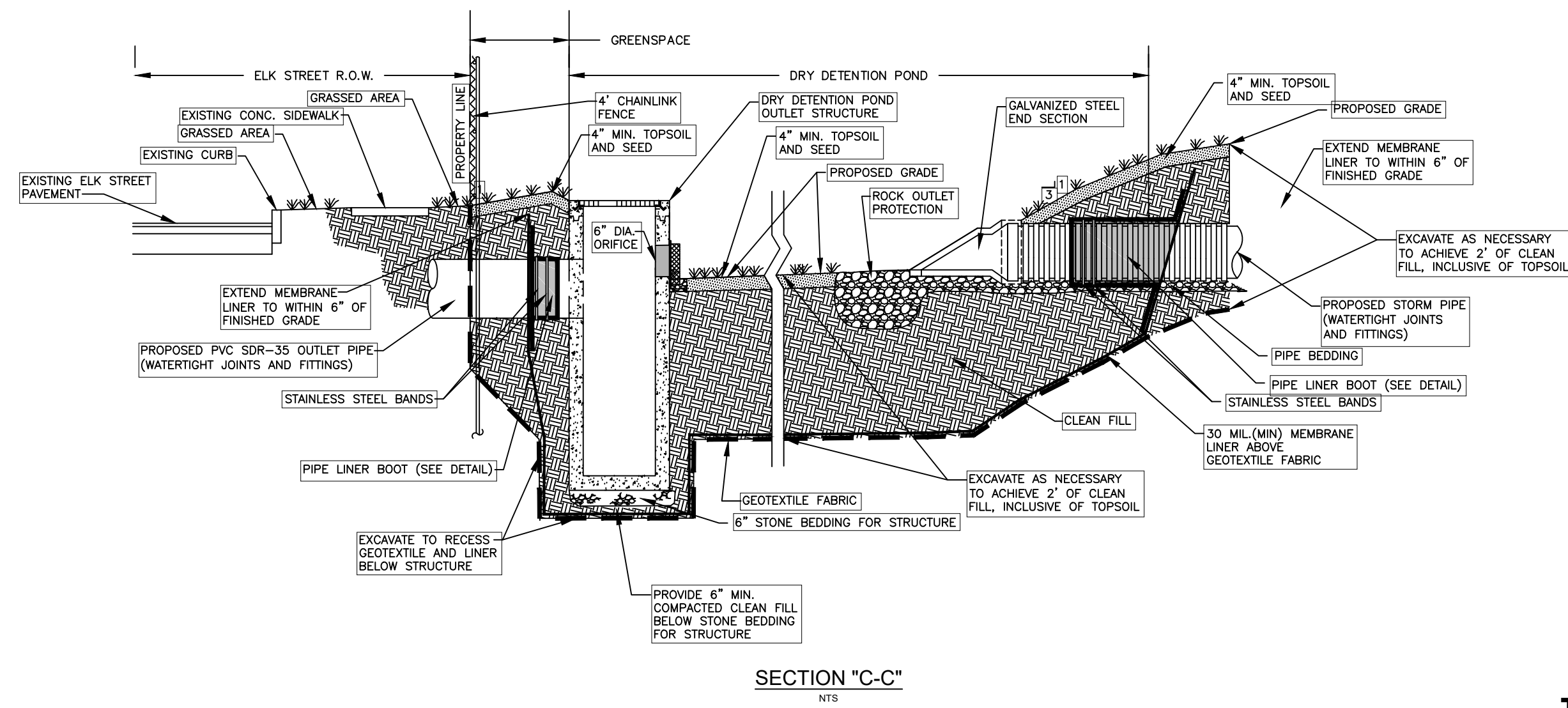

TYPICAL SECTIONS
NTS

NO.	DATE	REVISIONS
8		
7		
6		
5		
4		
3		
2		
1	08-17-18	ISSUED FOR AGENCY REVIEW - NOT FOR CONSTRUCTION
0		

UNAUTHORIZED ALTERATION OR ADDITION TO THESE PLANS IS A VIOLATION OF SECTION 7209, PROVISION 2 OF THE NEW YORK STATE EDUCATION LAW.



Prepared by:
ADVANCED DESIGN GROUP
PROFESSIONAL ENGINEERING & LAND SURVEYING, P.C.
781 CAYUGA STREET
BUFFALO, NY 14203
Phone: (716) 754-2256
Fax: (716) 754-4252

TYPICAL SECTIONS

Medaille College Athletic Complex
427 Elk Street
City of Buffalo, Erie County, New York 14210
South Buffalo Development, LLC
333 Ganson Street
Buffalo, NY 14203
Project Contact: Advanced Design Group (716) 754-2256

Scale: AS NOTED
Date: 7-16-18
Project no.: 18-4787
Sheet: 6 of 8

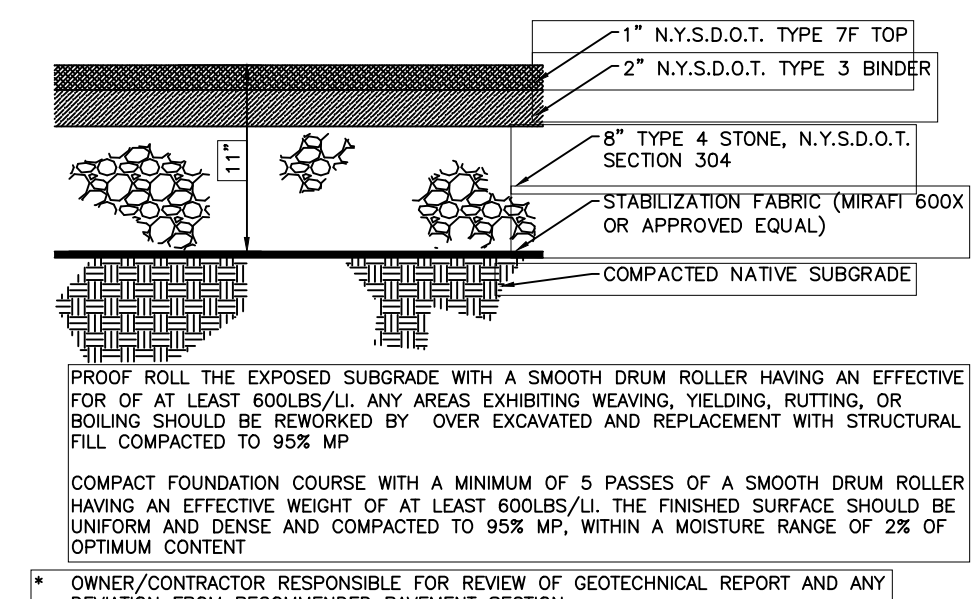

STANDARD DUTY PAVEMENT
NTS

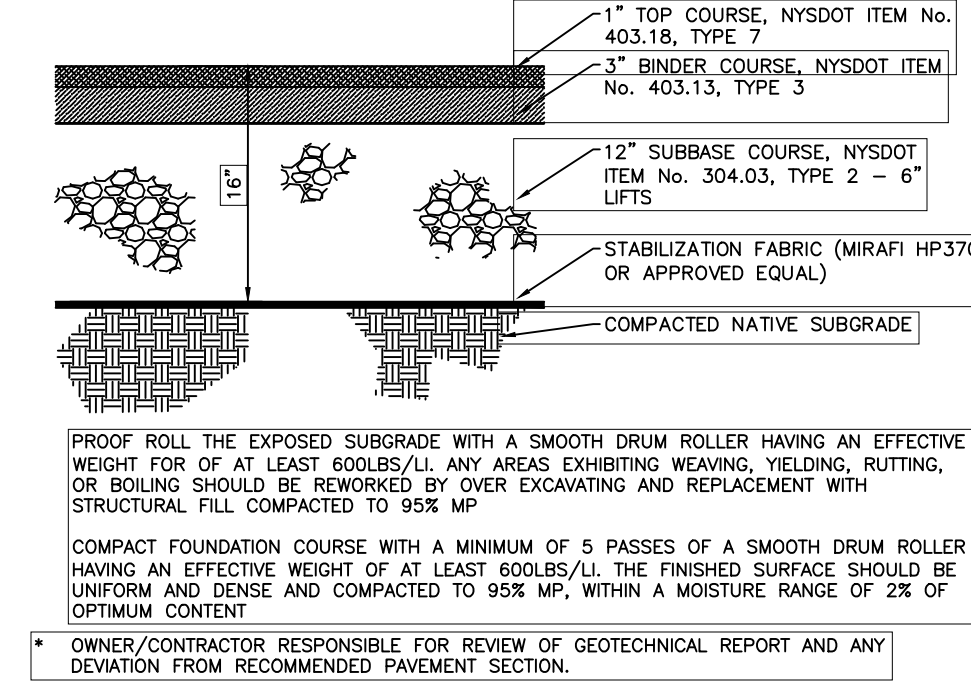

HEAVY DUTY PAVEMENT
NTS

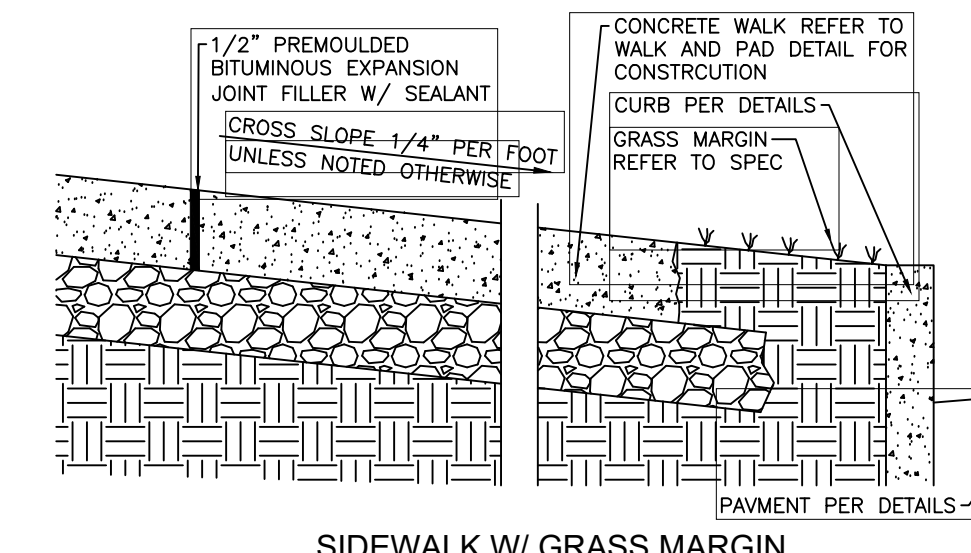

SIDEWALK W/ GRASS MARGIN
NTS

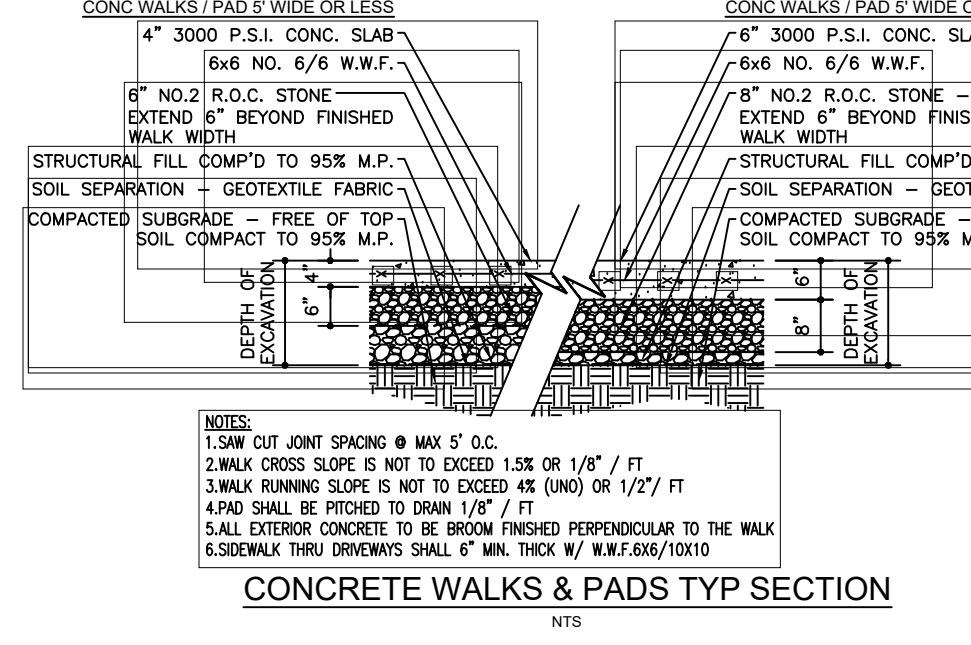

CONCRETE WALKS & PADS TYP SECTION
NTS

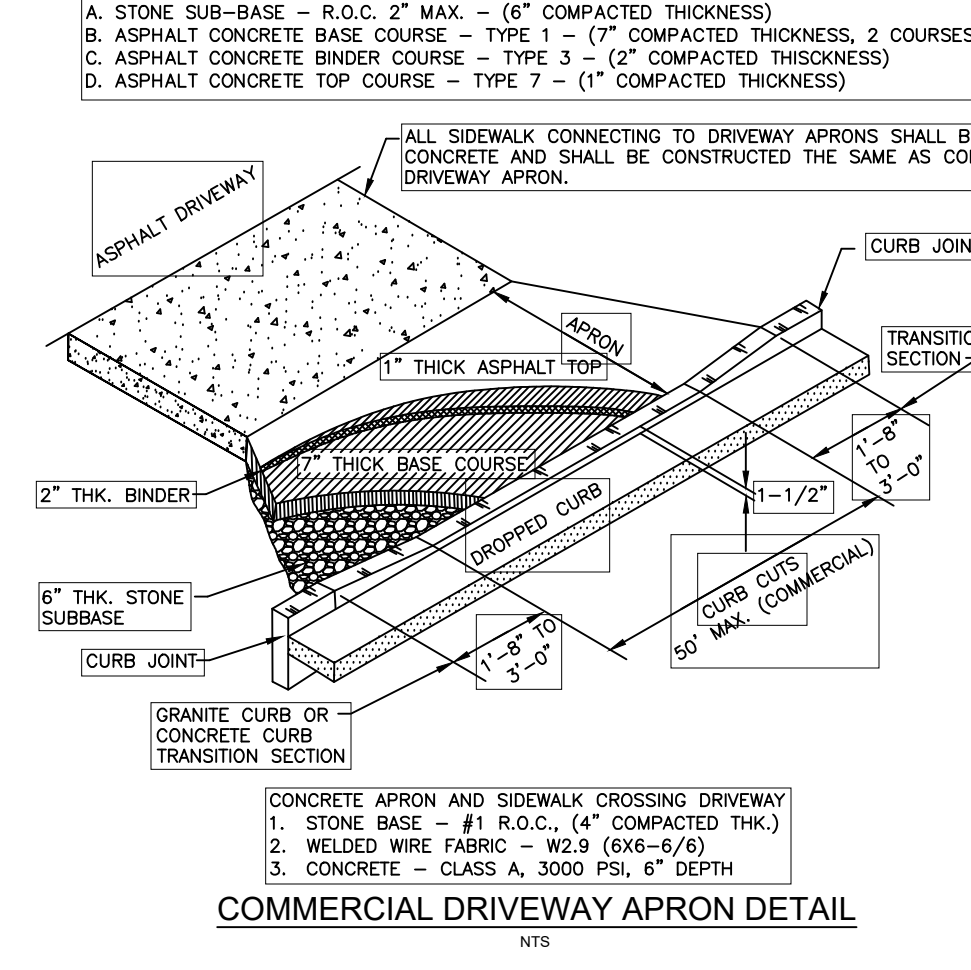

COMMERCIAL DRIVEWAY APRON DETAIL
NTS

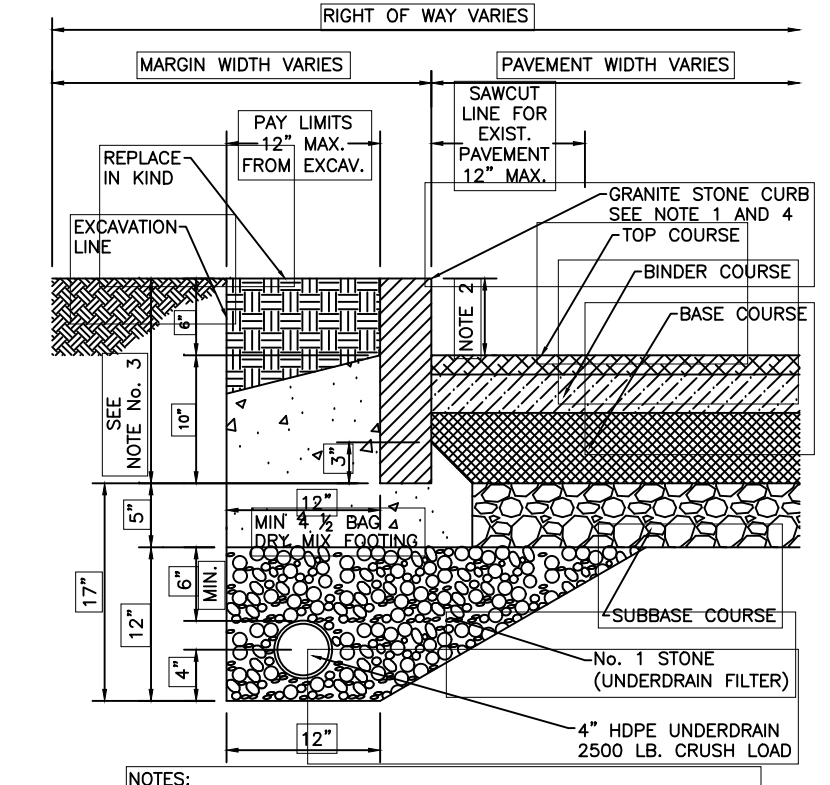

GRANITE STONE CURB
NTS

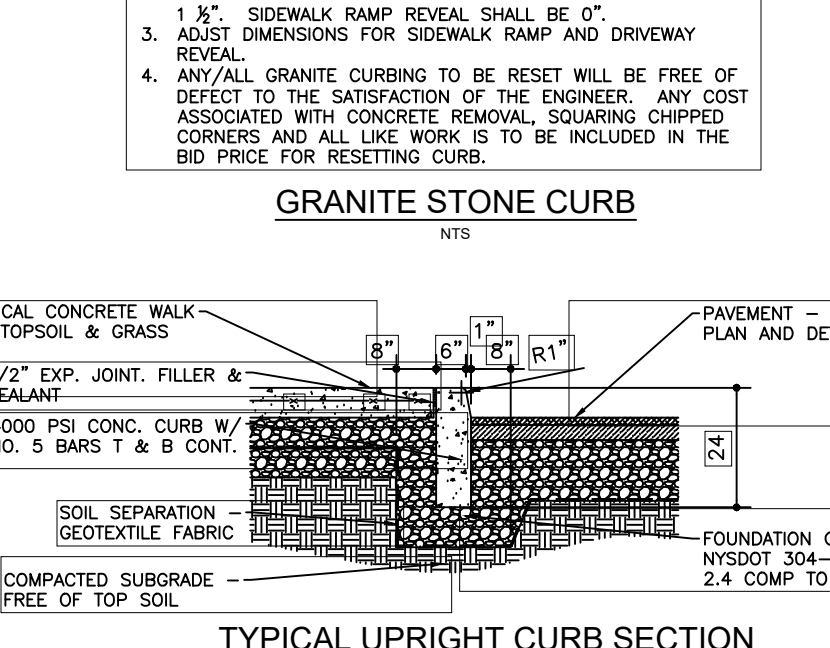

TYPICAL UPRIGHT CURB SECTION
NTS

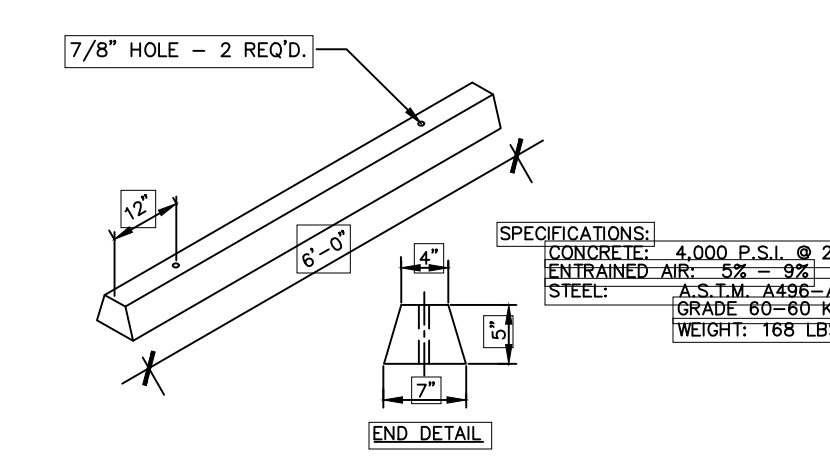

6\"/>

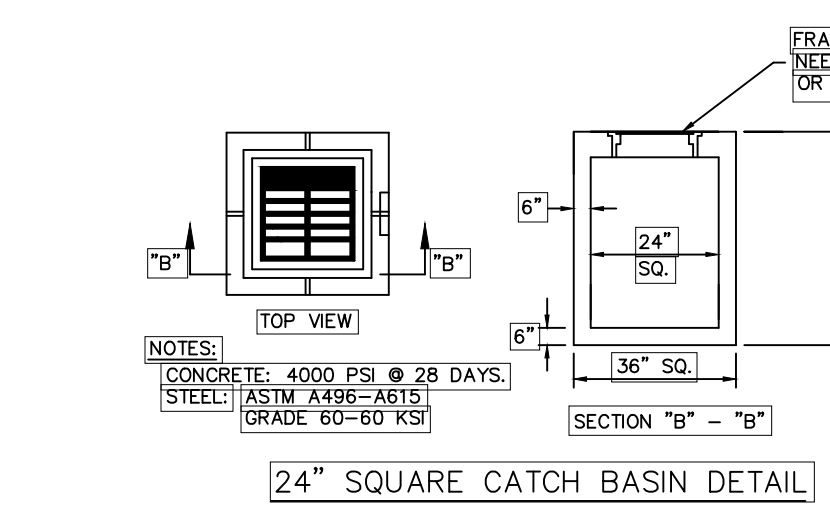

24\"/>

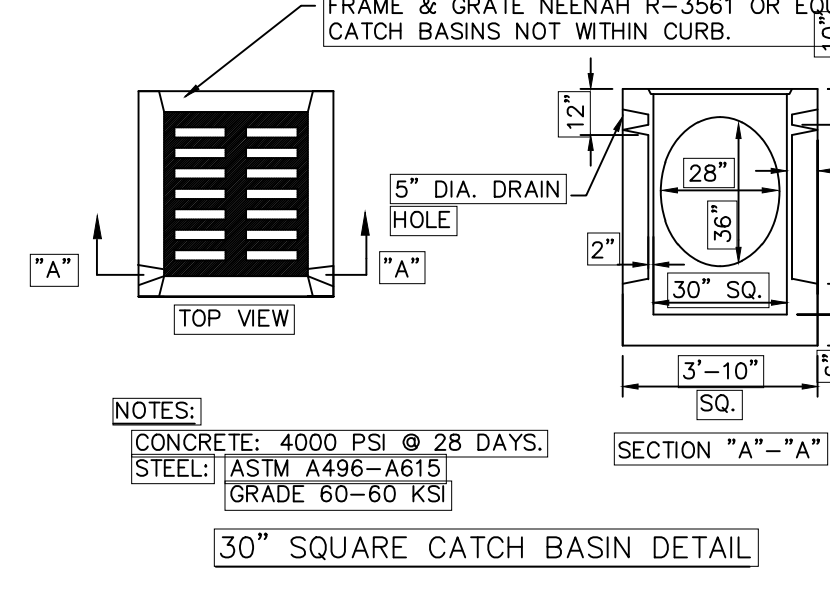

30\"/>

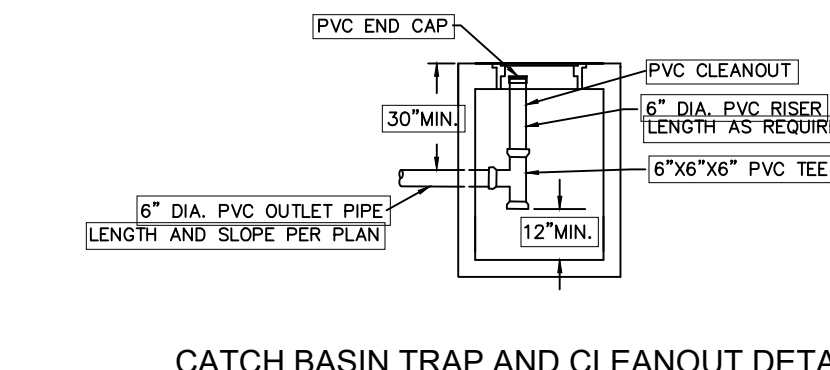

CATCH BASIN TRAP AND CLEANOUT DETAIL
NTS

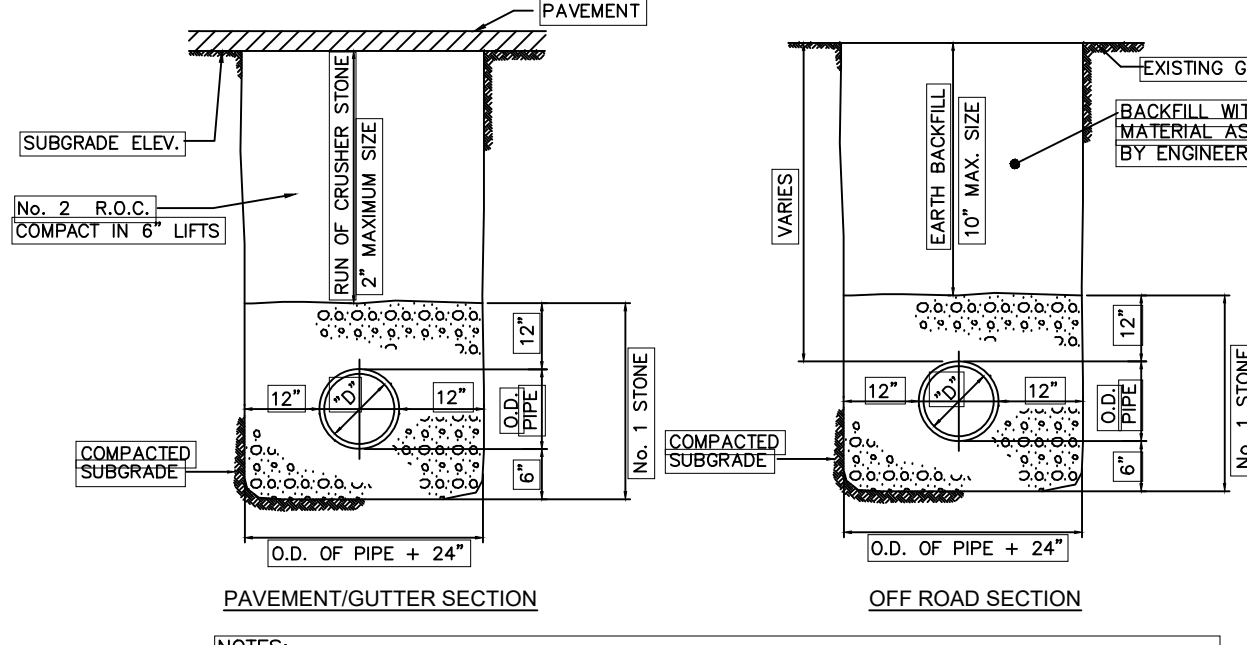

STORM SEWER TRENCH DETAILS
NTS

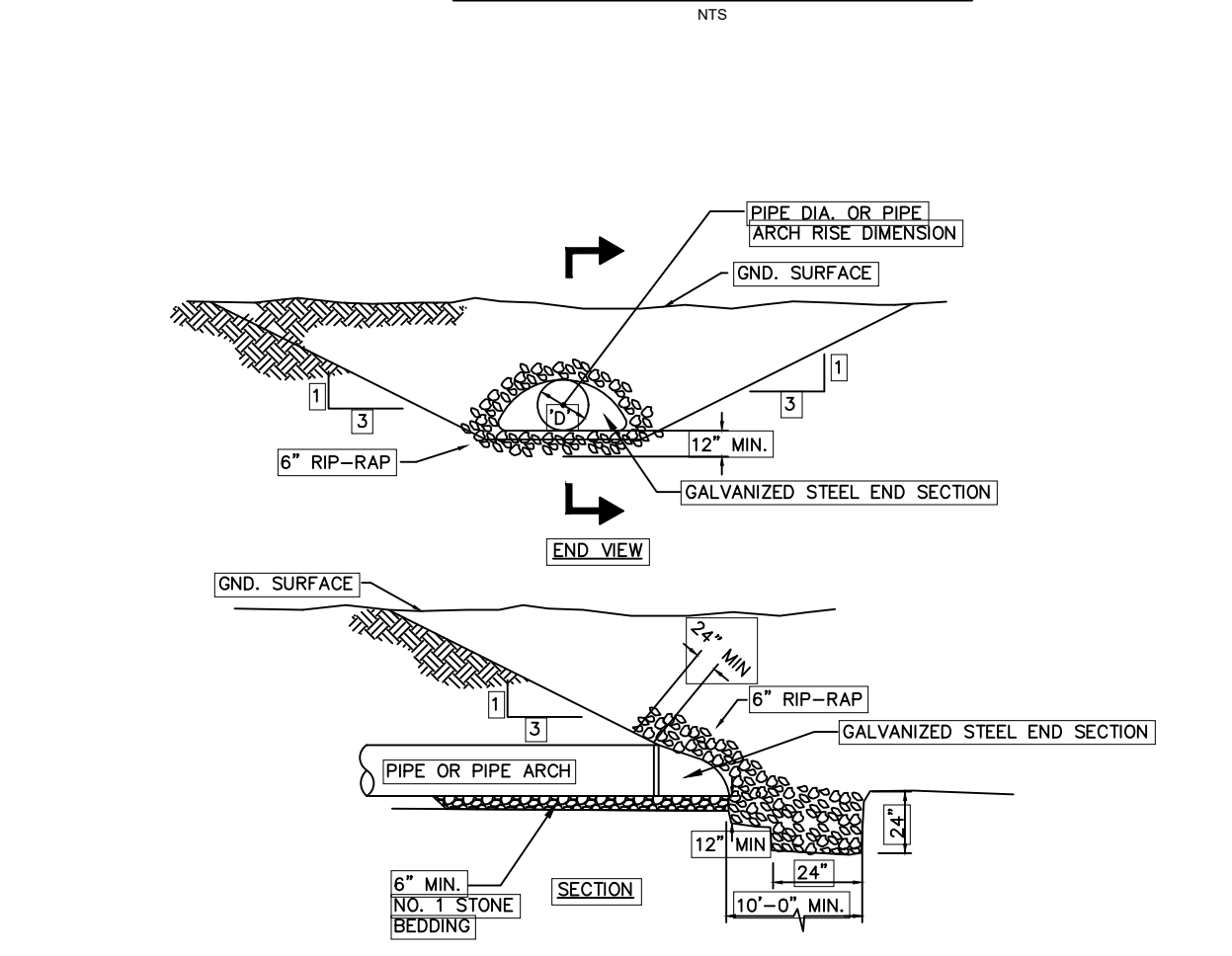

STONE FILLING FOR END SECTION DETAIL
NTS

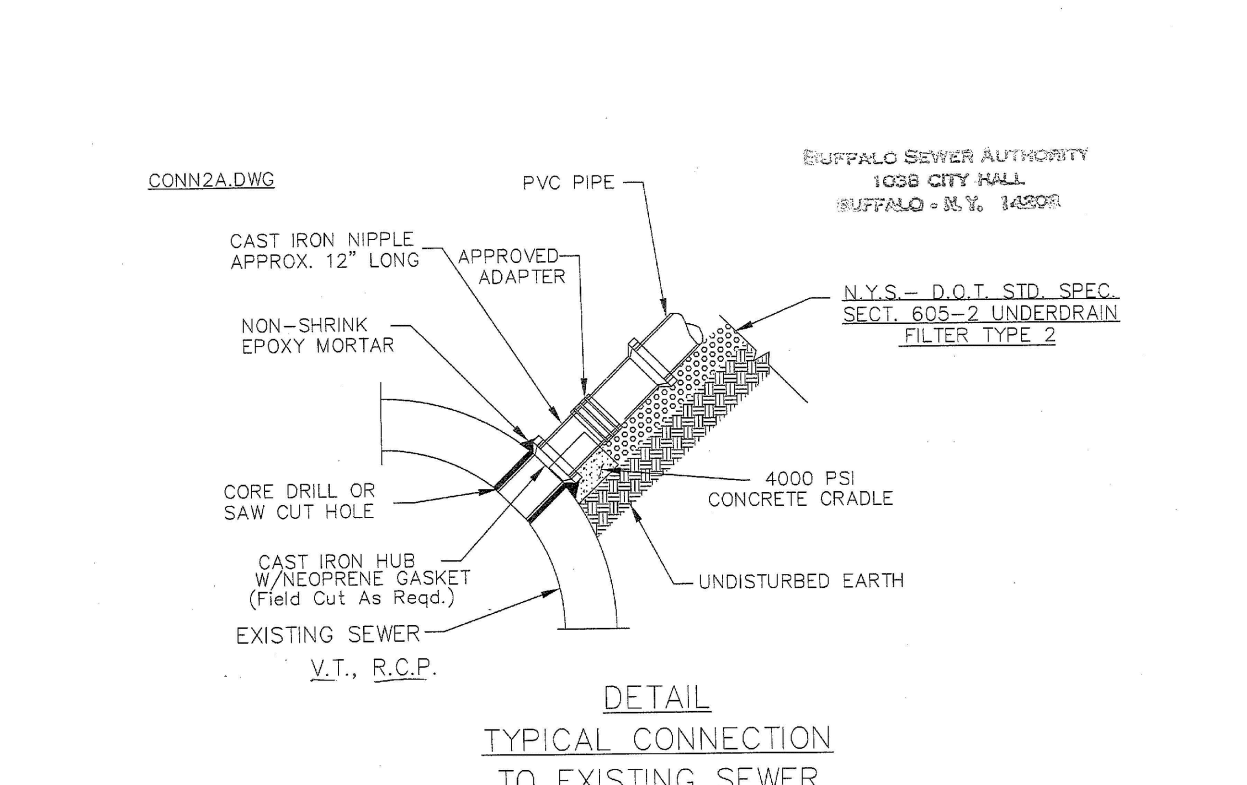

TYPICAL CONNECTION TO EXISTING SEWER
NTS

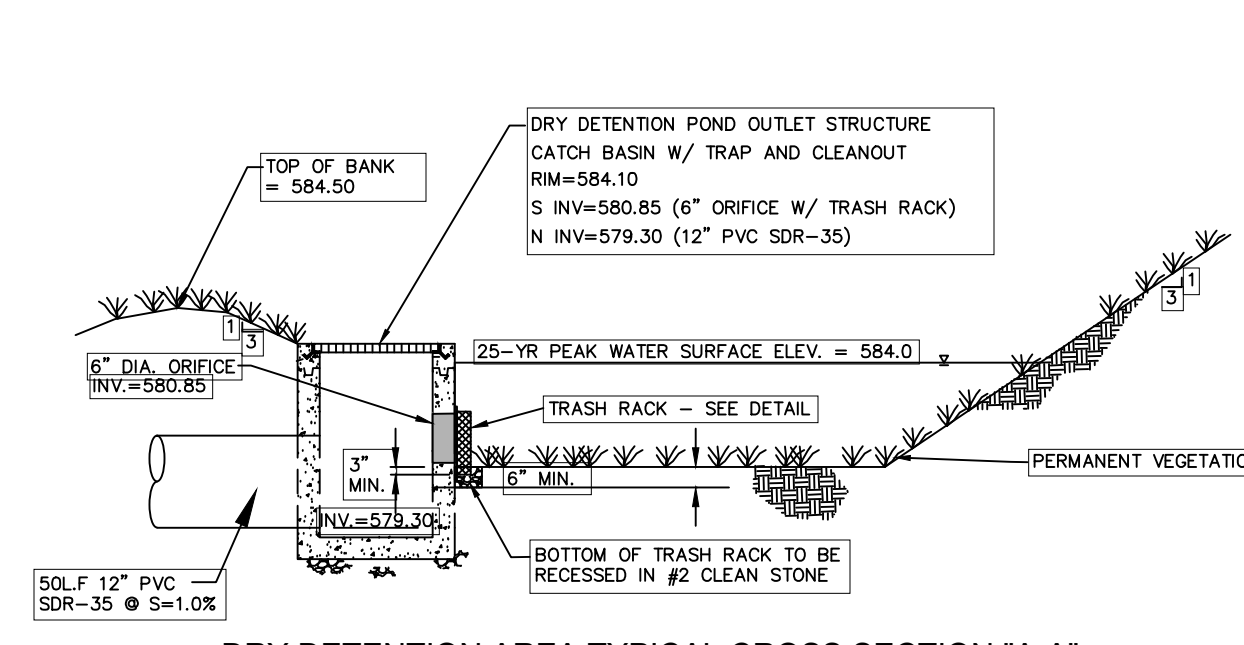

DRY DETENTION AREA TYPICAL CROSS SECTION "A-A"
NTS

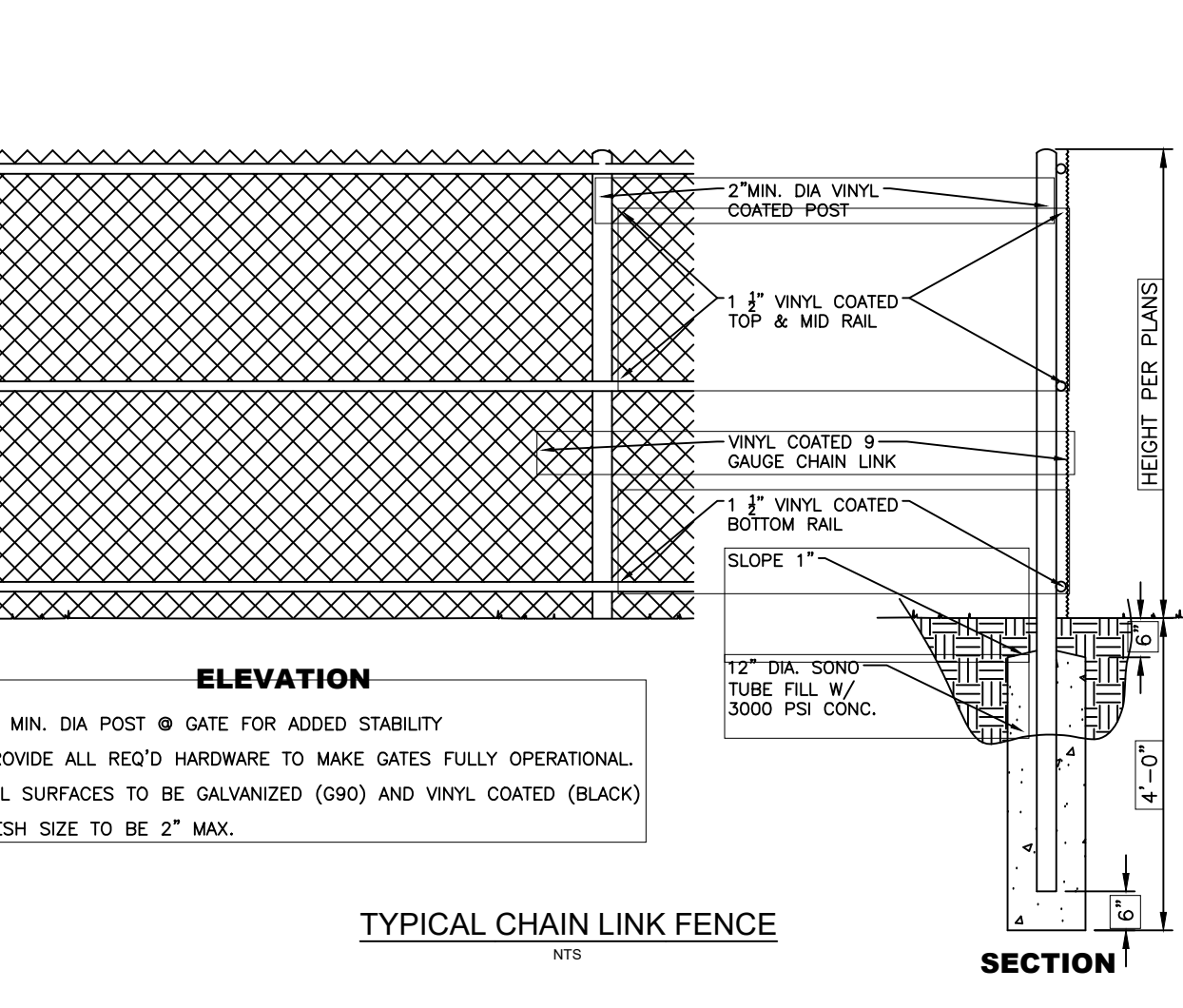

TYPICAL CHAIN LINK FENCE
NTS

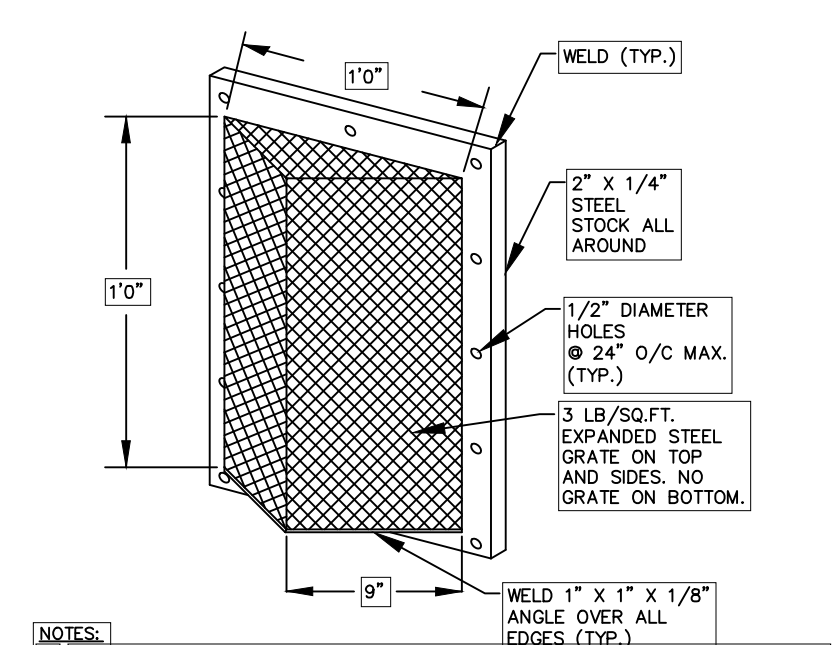

TRASH RACK TYPICAL DETAIL
NTS

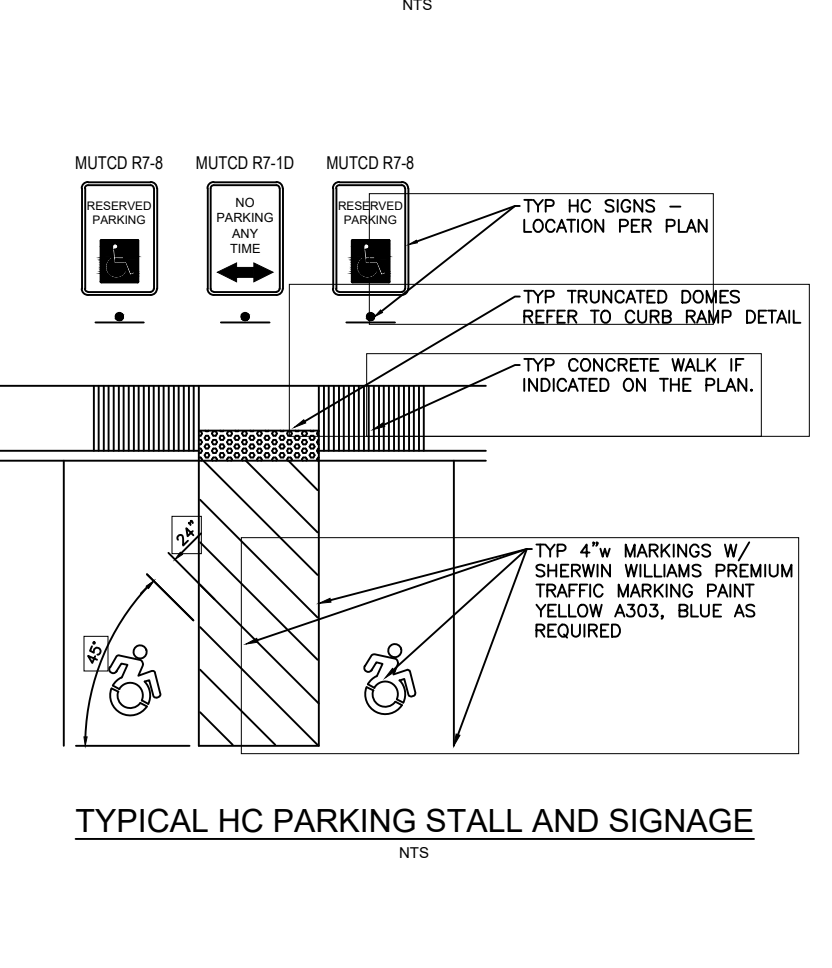

TYPICAL HC PARKING STALL AND SIGNAGE
NTS

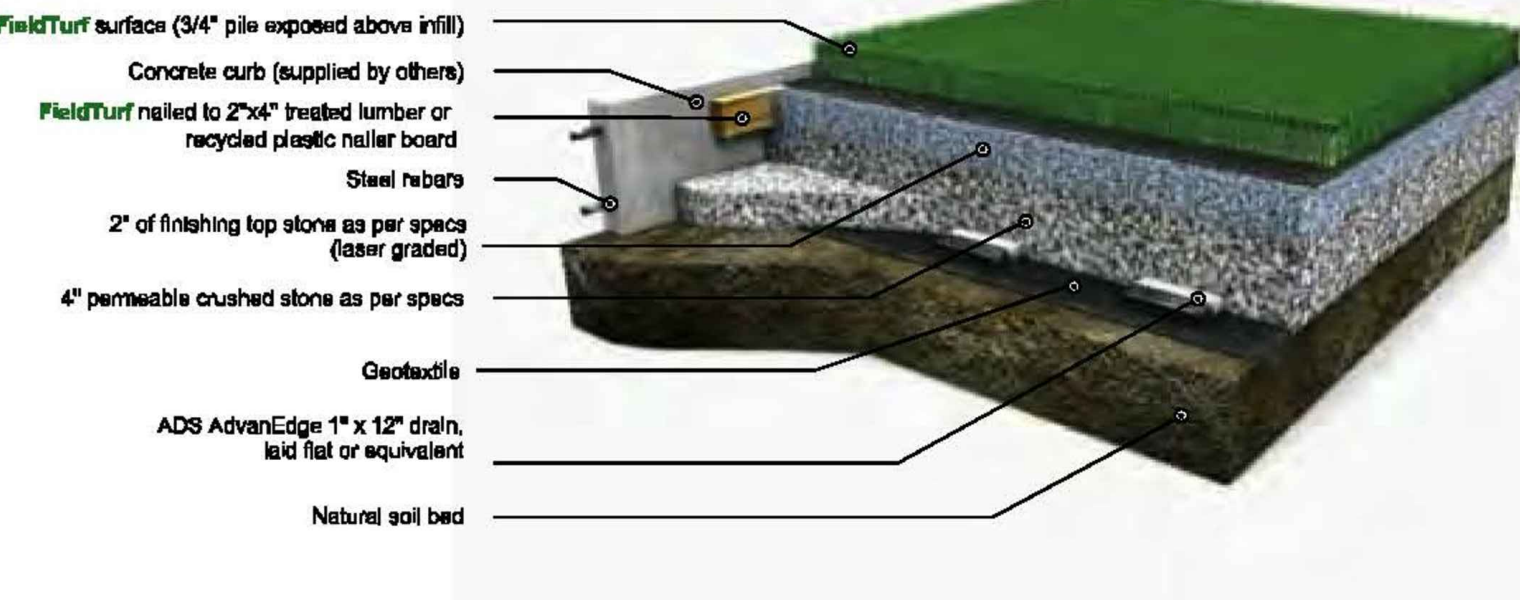

Edging Detail - Concrete Curb



Edging Detail - Recycled Plastic Curb

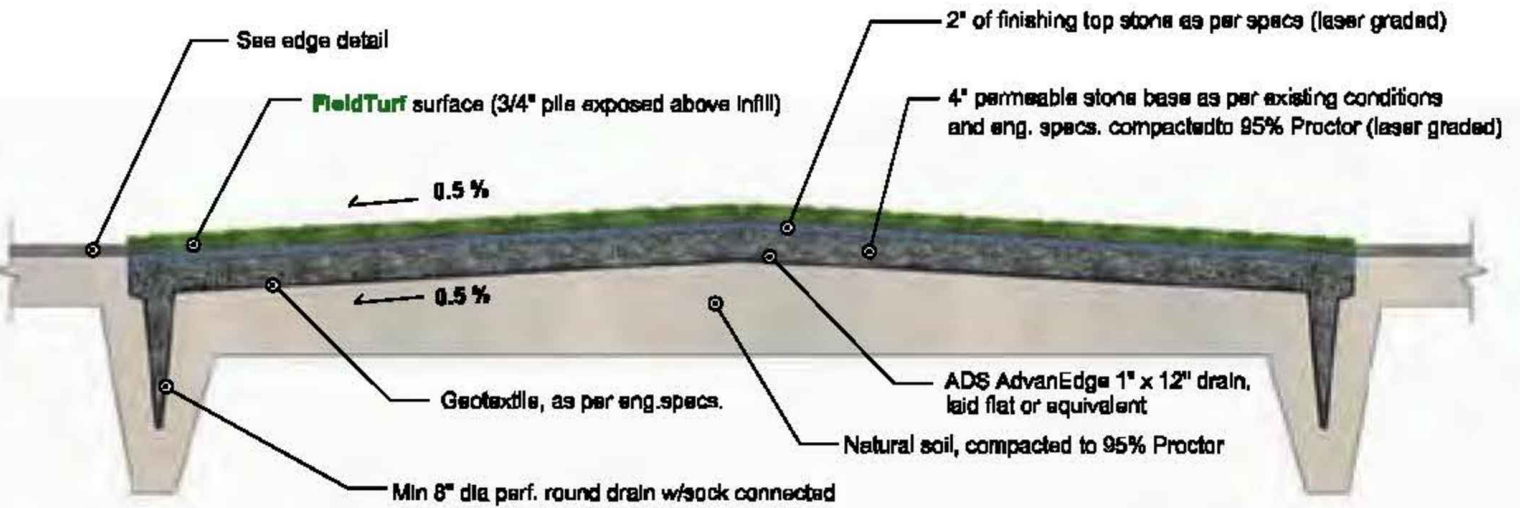

Base Cross-Section

SAMPLE ARTIFICIAL TURF DRAINAGE DETAILS
NTS

NO.	DATE	REVISIONS
8		
7		
6		
5		
4		
3		
2		
1	08-17-18	ISSUED FOR AGENCY REVIEW - NOT FOR CONSTRUCTION

UNAUTHORIZED ALTERATION OR ADDITION TO THESE PLANS IS A VIOLATION OF SECTION 7209, PROVISION 2 OF THE NEW YORK STATE EDUCATION LAW.

ADVANCED DESIGN GROUP
PROFESSIONAL ENGINEERING & LAND SURVEYING, P.C.
781 CAYUGA STREET
BUFFALO, NY 14203
PHONE: (716) 754-2256
FAX: (716) 754-4252

PAVING AND DRAINAGE DETAILS

Medaille College Athletic Complex
427 Elk Street
City of Buffalo, Erie County, New York 14210
South Buffalo Development, LLC
333 Ganson Street
Buffalo, NY 14203

Project Contact: Advanced Design Group (716) 754-2256

Scale: AS NOTED
Date: 7-16-18
Project No.: 18-4787
Sheet: 7 of 8

EROSION CONTROL NOTES:

1. ALL CONTRACTORS AND SUBCONTRACTORS INVOLVED WITH THE SITE DISTURBANCE ACTIVITIES SHALL BECOME FAMILIAR WITH THE EROSION AND SEDIMENT CONTROL PLAN.
2. ALL GRADED OR DISTURBED AREAS INCLUDING SLOPES SHALL BE PROTECTED DURING CLEARING AND CONSTRUCTION IN ACCORDANCE WITH THE APPROVED EROSION AND SEDIMENT CONTROL PLAN UNTIL THEY ARE PERMANENTLY STABILIZED.
3. ALL SEDIMENT CONTROL PRACTICES AND MEASURES SHALL BE INSTALLED/CONSTRUCTED, APPLIED AND MAINTAINED IN ACCORDANCE WITH THE STANDARDS AND SPECIFICATIONS FOR SOIL EROSION AND SEDIMENT CONTROL IN DEVELOPING AREAS.
4. LOCATION OF MATERIAL AND TOPSOIL STOCKPILE AREA TO BE VERIFIED BY CONTRACTOR PRIOR TO START OF CONSTRUCTION. MATERIAL AND TOPSOIL PILE TO BE ENCLOSED WITH SILT FENCING AND TEMPORARILY VEGETATED.
5. TOPSOIL REQUIRED FOR THE ESTABLISHMENT OF VEGETATION SHALL BE STOCKPILED IN AMOUNT NECESSARY TO COMPLETE FINISHED GRADING OF ALL EXPOSED AREAS.
6. AREAS TO BE FILLED SHALL BE CLEARED, GRUBBED AND STRIPPED OF TOPSOIL TO REMOVE TREES, VEGETATION, ROOTS OR OTHER OBJECTIONABLE MATERIAL.
7. AREAS WHICH ARE TO BE TOPSOILED SHALL BE SCARIFIED TO A MINIMUM DEPTH OF FOUR INCHES PRIOR TO PLACEMENT OF TOPSOIL.
8. ALL FILLS SHALL BE COMPACTED AS REQUIRED TO REDUCE EROSION, SLIPPAGE, SETTLEMENT, SUBSIDENCE OR OTHER RELATED PROBLEMS. FILL INTENDED TO SUPPORT BUILDINGS, STRUCTURES AND CONDUITS, ETC. SHALL BE COMPACTED IN ACCORDANCE WITH LOCAL REQUIREMENTS OR CODES.
9. ALL FILL TO BE PLACED AND COMPACTED IN LAYERS NOT TO EXCEED 6 INCHES IN THICKNESS.
10. FILL MATERIAL SHALL BE FREE OF FROZEN PARTICLES, BRUSH, ROOTS, SOD OR OTHER FOREIGN OR OTHER OBJECTIONABLE MATERIALS THAT WOULD INTERFERE WITH OR PREVENT CONSTRUCTION OF SATISFACTORY FILLS. FROZEN MATERIALS OR SOFT, MUCKY OR HIGHLY COMPRESSIBLE MATERIALS SHALL NOT BE INCORPORATED IN FILLS.
11. FILL SHALL NOT BE PLACED ON SATURATED OR FROZEN SURFACES.
12. ALL GRADED AREAS SHALL BE PERMANENTLY STABILIZED IMMEDIATELY FOLLOWING FINISHED GRADING.

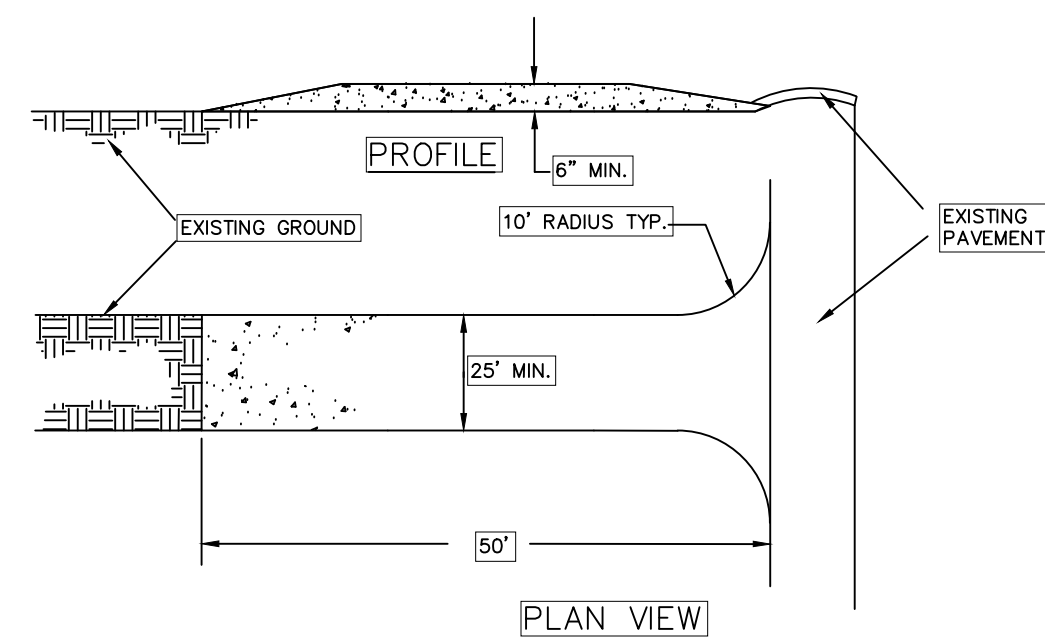

1. STONE SIZE - USE 2" STONE, OR RECLAIMED OR RECYCLED CONCRETE EQUIVALENT.
2. LENGTH - AS REQUIRED, BUT NOT LESS THAN 50'.
3. THICKNESS - NOT LESS THAN 6".
4. WIDTH - 10' MINIMUM, BUT NO LESS THAN THE FULL WIDTH AT POINTS WHERE INGRESS OR EGRESS OCCURS.
5. FILTER CLOTH - WILL BE PLACED OVER THE ENTIRE AREA PRIOR TO PLACING OF STONE.
6. MAINTENANCE - THE ENTRANCE SHALL BE MAINTAINED IN A CONDITION WHICH WILL PREVENT TRACKING OR FLOWING OF SEDIMENT ONTO PUBLIC RIGHTS-OF-WAY. THIS MAY REQUIRE PERIODIC TOP DRESSING WITH ADDITIONAL STONE AS CONDITIONS DEMAND AND REPAIR AND/OR CLEANOUT OF ANY MEASURES USED TO TRAP SEDIMENT. ALL SEDIMENT SPILLED, DROPPED, WASHED, OR TRACKED ONTO PUBLIC RIGHTS-OF-WAY MUST BE REMOVED IMMEDIATELY.
7. PERIODIC INSPECTION AND NEEDED MAINTENANCE SHALL BE PROVIDED AFTER EACH RAIN.

STABILIZED CONSTRUCTION ENTRANCE DETAIL
NTS

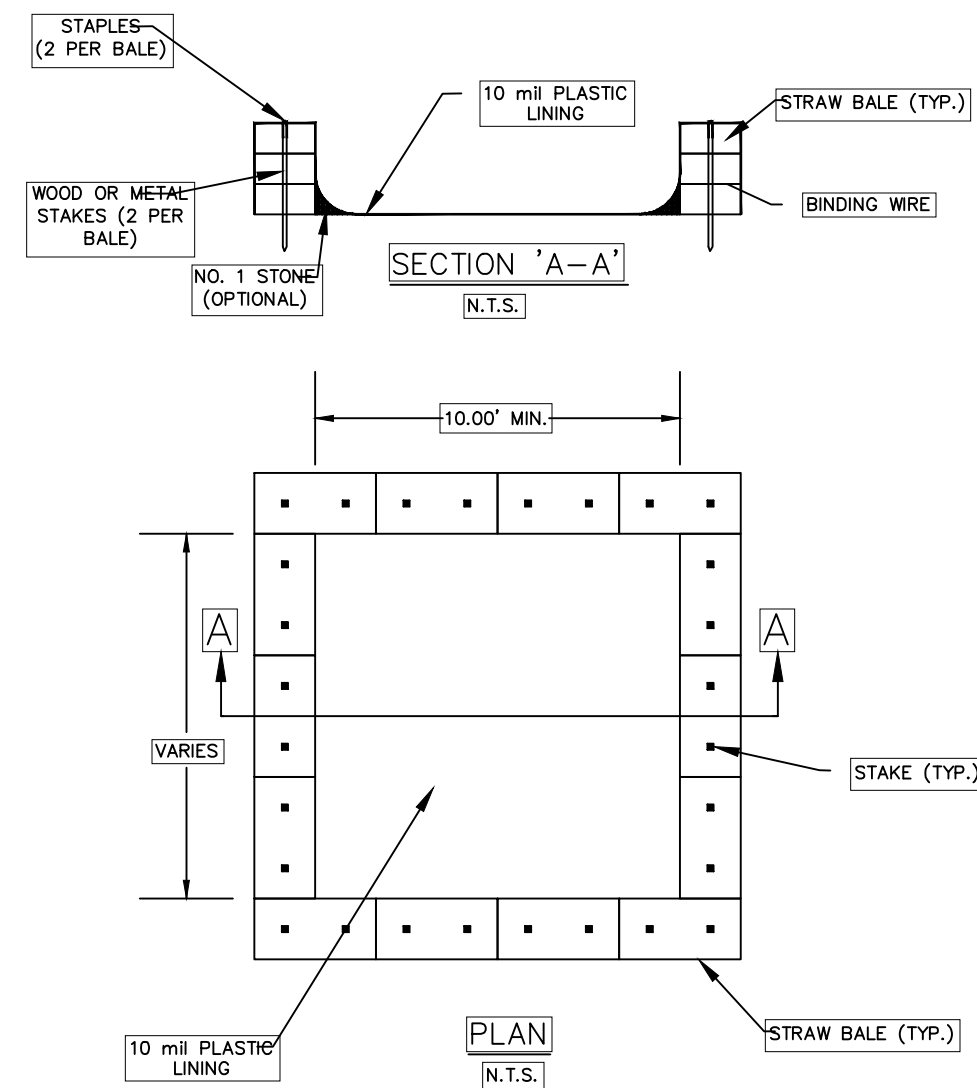

- NOTES:
1. ACTUAL LAYOUT DETERMINED IN FIELD.
 2. THE CONCRETE WASHOUT SIGN SHALL BE INSTALLED WITHIN 30 FT. OF THE TEMPORARY WASHOUT FACILITY.
 3. THE CONCRETE WASHOUT STRUCTURE SHALL BE MAINTAINED WHEN THE LIQUID AND/OR SOLID REACHES 75% OF THE STRUCTURE'S CAPACITY.
 4. THE PLASTIC LINING SHALL BE FREE OF TEARS OR HOLES THAT WOULD ALLOW WASHWATER TO ESCAPE.

TYPICAL ABOVE GRADE CONCRETE WASHOUT INSTALLATION DETAIL
NTS

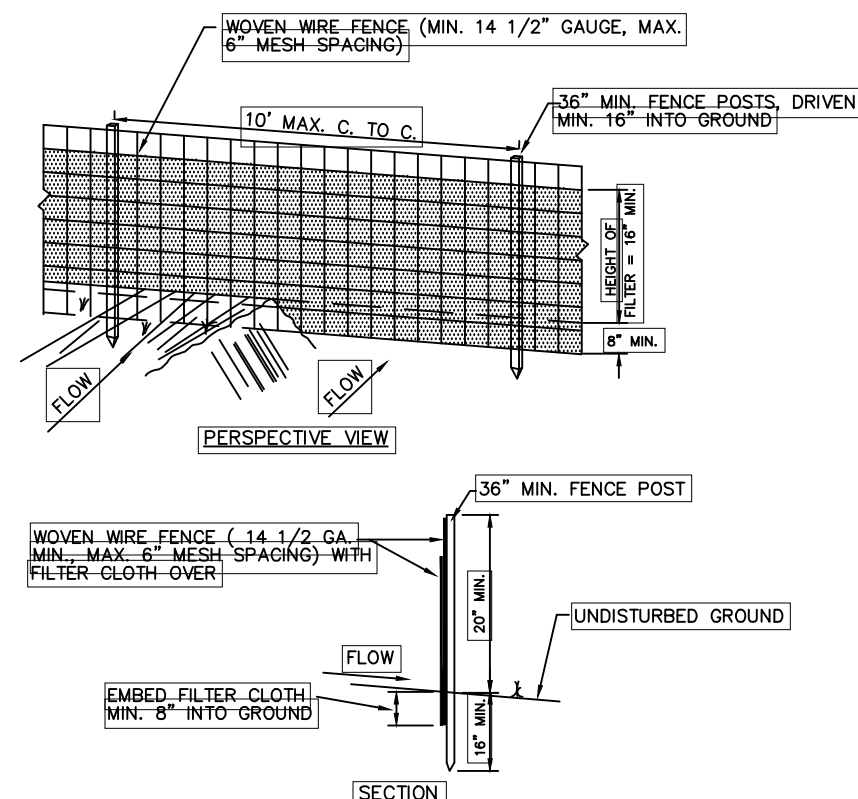

- CONSTRUCTION NOTES FOR FABRICATED SILT FENCE**
1. WOVEN WIRE FENCE TO BE FASTENED SECURELY TO FENCE POSTS WITH WIRE TIES OR STAPLES (TYPE OR 2" HARDWOOD).
 2. FILTER CLOTH TO BE FASTENED SECURELY TO WOVEN WIRE FENCE WITH TIES SPACED EVERY 24" AT TOP AND MID SECTION.
 3. WHEN TWO SECTIONS OF FILTER CLOTH ADJOIN EACH OTHER THEY SHALL BE OVERLAPPED BY SIX INCHES AND FOLDED.
 4. MAINTENANCE SHALL BE PERFORMED AS NEEDED AND MATERIAL REMOVED WHEN "BOULGERS" DEVELOP IN THE SILT FENCE.

SILT FENCE DETAIL
NTS

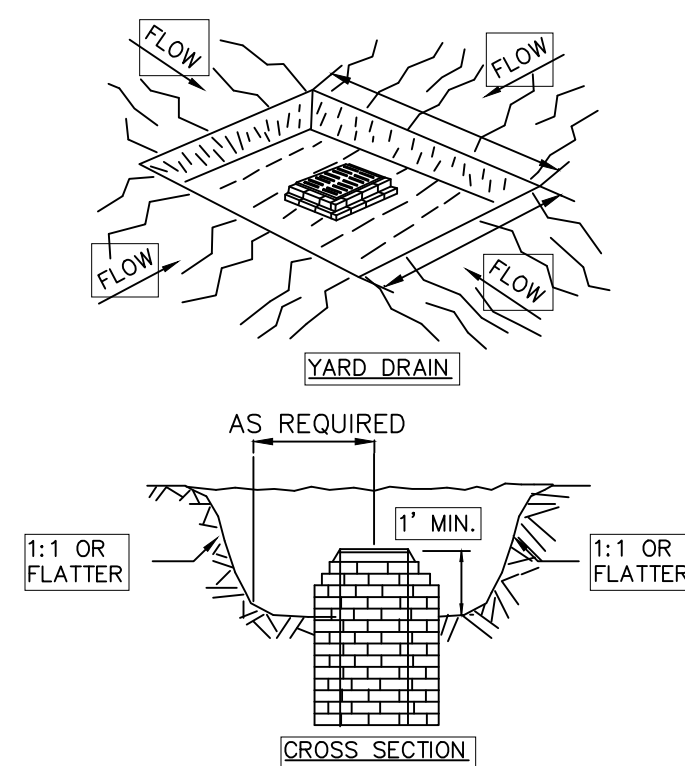

- CONSTRUCTION SPECIFICATIONS**
1. SEDIMENT SHALL BE REMOVED AND THE TRAP RESTORED TO ITS ORIGINAL DIMENSIONS WHEN THE SEDIMENT HAS ACCUMULATED TO 1/2 THE DESIGN DEPTH OF THE TRAP. REMOVED SEDIMENT SHALL BE DEPOSITED IN A SUITABLE AREA AND IN SUCH A MANNER THAT IT WILL NOT ERODE.
 2. THE VOLUME OF SEDIMENT STORAGE SHALL BE 1800 CUBIC FEET PER ACRE OF CONTRIBUTORY DRAINAGE.
 3. THE STRUCTURE SHALL BE INSPECTED AFTER EACH RAIN AND REPAIRS MADE AS NEEDED.
 4. CONSTRUCTION OPERATIONS SHALL BE CARRIED OUT IN SUCH A MANNER THAT EROSION AND WATER POLLUTION SHALL BE MINIMIZED.
 5. THE SEDIMENT TRAP SHALL BE REMOVED AND THE AREA STABILIZED WHEN THE CONSTRUCTED DRAINAGE AREA HAS BEEN PROPERLY STABILIZED.
 6. ALL CUT SLOPES SHALL BE 1:1 OR FLATTER. MAXIMUM DRAINAGE AREA: 3 ACRES.

EXCAVATED INLET PROTECTION
NTS

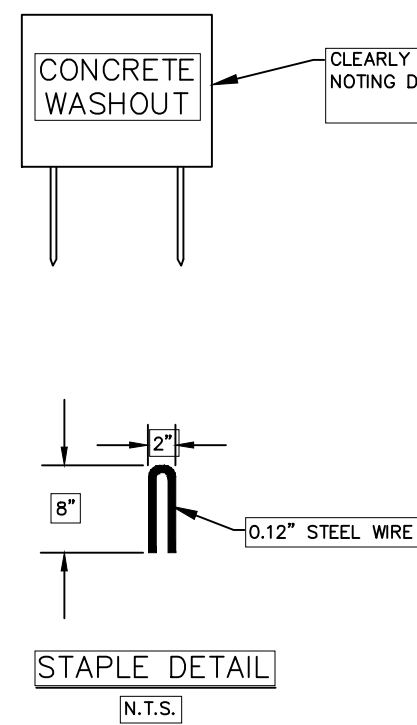

STAPLE DETAIL
NTS

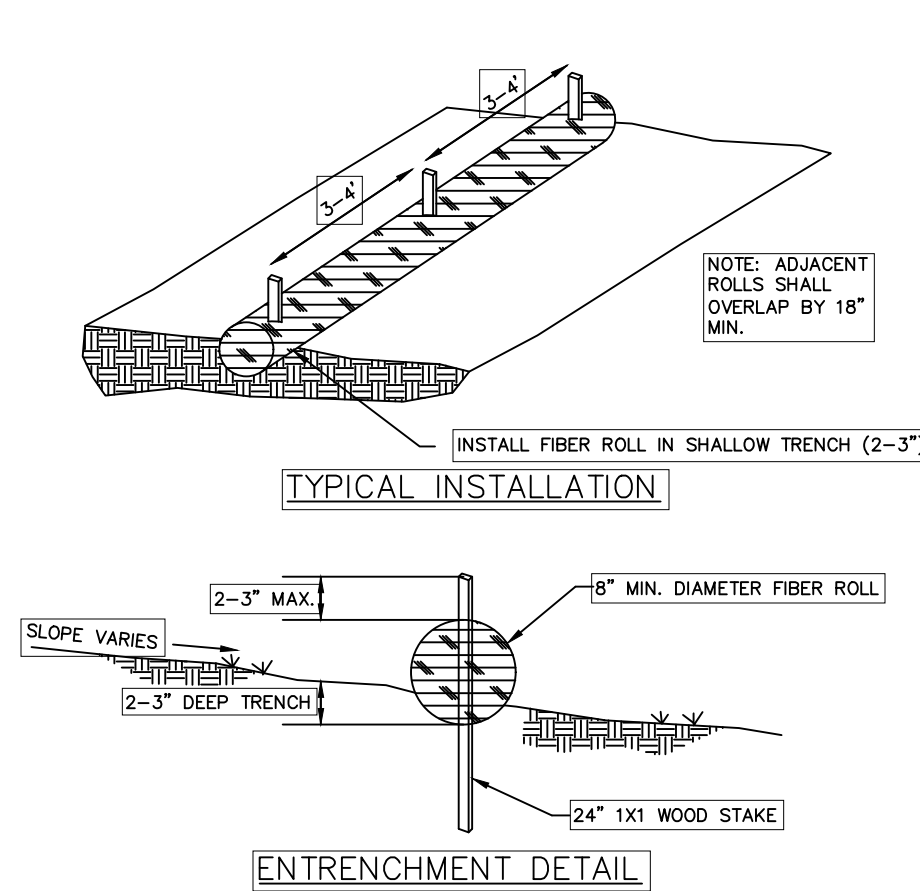

TYPICAL FIBER ROLL INSTALLATION DETAIL
NTS

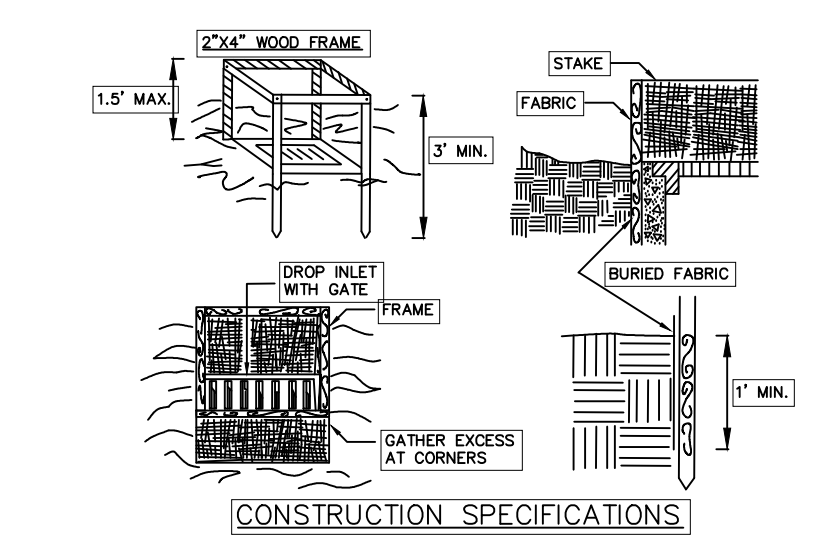

- CONSTRUCTION SPECIFICATIONS**
1. FILTER FABRIC SHALL HAVE AN EOG OF 40-85. BURLAP MAY BE USED FOR SHORT TERM APPLICATIONS.
 2. CUT FABRIC FROM A CONTINUOUS ROLL TO ELIMINATE JOINTS. IF JOINTS ARE NEEDED THEY WILL BE OVERLAPPED TO THE NEXT STAKE.
 3. STAKE MATERIALS WILL BE STANDARD 2" x 4" WOOD OR EQUIVALENT METAL WITH A MINIMUM LENGTH OF 3 FEET.
 4. SPACE STAKES EVENLY AROUND INLET 3 FEET APART AND DRIVE A MINIMUM 18 INCHES DEEP. SPANS GREATER THAN 3 FEET MAY BE BRIDGED WITH THE USE OF WIRE MESH BEHIND THE FILTER FABRIC FOR SUPPORT.
 5. FABRIC SHALL BE EMBOSSED 1 FOOT MINIMUM BELOW GROUND AND BACKFILLED. IT SHALL BE SECURELY FASTENED TO THE STAKES AND FRAME.
 6. A 2" x 4" WOOD FRAME SHALL BE COMPLETED AROUND THE CREST OF THE FABRIC FOR OVER FLOW STABILITY. MAXIMUM DRAINAGE AREA: 1 ACRE.

FILTER FABRIC DROP INLET PROTECTION
NTS

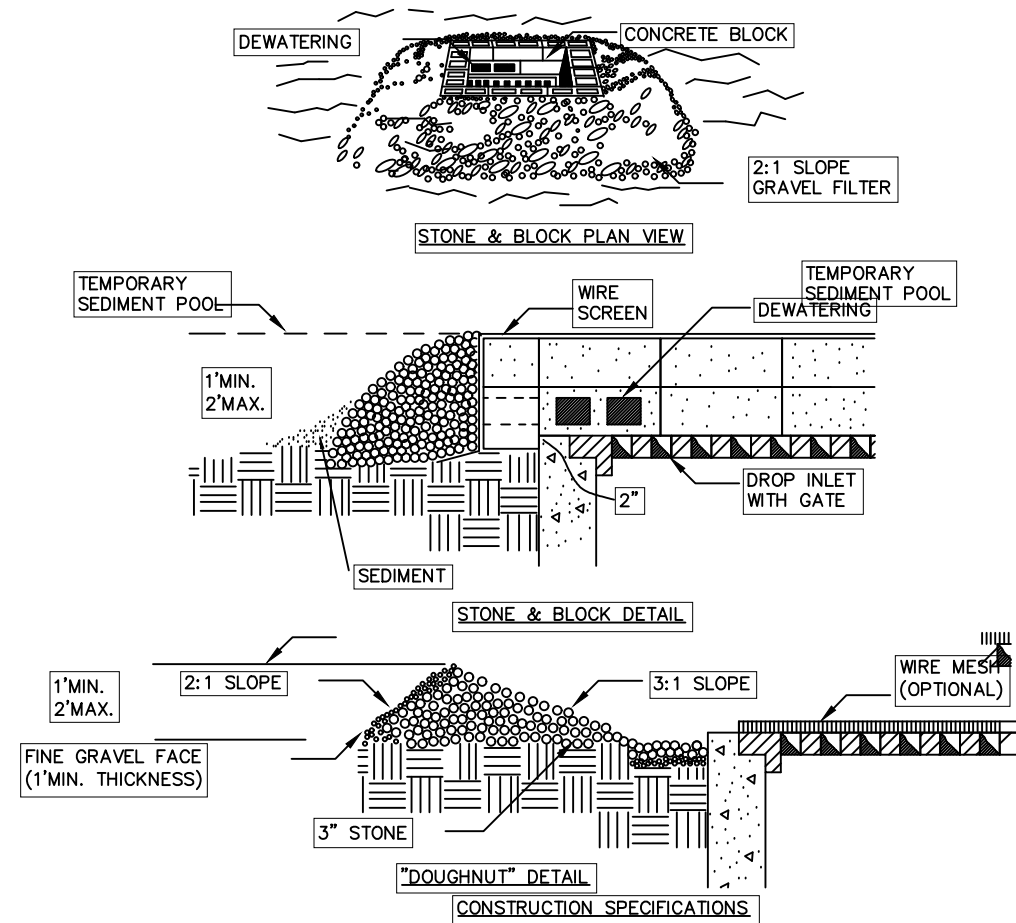

- CONSTRUCTION SPECIFICATIONS**
1. LAY ONE BLOCK ON EACH SIDE OF THE STRUCTURE ON ITS SIDE FOR DEWATERING. FOUNDATION SHALL BE 2 INCHES MINIMUM BELOW REST OF INLET AND BLOCKS SHALL BE PLACED AGAINST INLET FOR SUPPORT.
 2. HARDWARE CLOTH OR 1/2" WIRE MESH SHALL BE PLACED OVER BLOCK OPENINGS TO SUPPORT STONE.
 3. USE CLEAN STONE OR GRAVEL 1/2-3/4 INCH IN DIAMETER PLACED 2 INCHES BELOW TOP OF THE BLOCK ON A 2:1 SLOPE OR FLATTER.
 4. FOR STONE STRUCTURES ONLY, A 1 FOOT THICK LAYER OF THE FILTER STONE WILL BE PLACED AGAINST THE 3 INCH STONE AS SHOWN ON THE DRAWINGS. MAXIMUM DRAINAGE AREA 1 ACRE.

STONE AND BLOCK INLET PROTECTION (IP)
NTS

NO.	DATE	ISSUED FOR AGENCY REVIEW - NOT FOR CONSTRUCTION REVISIONS
8		
7		
6		
5		
4		
3		
2		
1		
0	08-17-18	

UNAUTHORIZED ALTERATION OR ADDITION TO THESE PLANS IS A VIOLATION OF SECTION 7209, PROVISION 2 OF THE NEW YORK STATE EDUCATION LAW.	
Prepared by: ADVANCED DESIGN GROUP PROFESSIONAL ENGINEERING & LAND SURVEYING, PC 781 Cayuga Street Buffalo, NY 14206 Phone: (716) 754-2256 Fax: (716) 754-4252	

PAVING AND DRAINAGE DETAILS Medaille College Athletic Complex 427 Elk Street City of Buffalo, Erie County, New York 14210 South Buffalo Development, LLC 333 Ganson Street Buffalo, NY 14203 Project Contact: Advanced Design Group (716) 754-2256	Project no.: 18-4787 Date: 7-16-18 Sheet: 8 of 8
	AS NOTED

APPENDICIES

A - Health and Safety Plan

B - Community Air Monitoring Plan

**Remedial Action Work Plan
Area E
Former Buffalo Color Corporation**

The NYS Department of Health (DOH) Generic Community Air Monitoring Plan (CAMP) will be implemented at the Area E site during the following activities:

- Continuous Air Monitoring:
 - Removal of pavement;
 - Removal of slabs in contact with soil;
 - Excavations that expose soils below the existing cover;
- Periodic Air Monitoring:
 - Loading of potentially contaminated soils or debris from stockpiles.

Appendix 1A

New York State Department of Health Generic Community Air Monitoring Plan

Overview

A Community Air Monitoring Plan (CAMP) requires real-time monitoring for volatile organic compounds (VOCs) and particulates (i.e., dust) at the downwind perimeter of each designated work area when certain activities are in progress at contaminated sites. The CAMP is not intended for use in establishing action levels for worker respiratory protection. Rather, its intent is to provide a measure of protection for the downwind community (i.e., off-site receptors including residences and businesses and on-site workers not directly involved with the subject work activities) from potential airborne contaminant releases as a direct result of investigative and remedial work activities. The action levels specified herein require increased monitoring, corrective actions to abate emissions, and/or work shutdown. Additionally, the CAMP helps to confirm that work activities did not spread contamination off-site through the air.

The generic CAMP presented below will be sufficient to cover many, if not most, sites. Specific requirements should be reviewed for each situation in consultation with NYSDOH to ensure proper applicability. In some cases, a separate site-specific CAMP or supplement may be required. Depending upon the nature of contamination, chemical-specific monitoring with appropriately-sensitive methods may be required. Depending upon the proximity of potentially exposed individuals, more stringent monitoring or response levels than those presented below may be required. Special requirements will be necessary for work within 20 feet of potentially exposed individuals or structures and for indoor work with co-located residences or facilities. These requirements should be determined in consultation with NYSDOH.

Reliance on the CAMP should not preclude simple, common-sense measures to keep VOCs, dust, and odors at a minimum around the work areas.

Community Air Monitoring Plan

Depending upon the nature of known or potential contaminants at each site, real-time air monitoring for VOCs and/or particulate levels at the perimeter of the exclusion zone or work area will be necessary. Most sites will involve VOC and particulate monitoring; sites known to be contaminated with heavy metals alone may only require particulate monitoring. If radiological contamination is a concern, additional monitoring requirements may be necessary per consultation with appropriate DEC/NYSDOH staff.

Continuous monitoring will be required for all ground intrusive activities and during the demolition of contaminated or potentially contaminated structures. Ground intrusive activities include, but are not limited to, soil/waste excavation and handling, test pitting or trenching, and the installation of soil borings or monitoring wells.

Periodic monitoring for VOCs will be required during non-intrusive activities such as the collection of soil and sediment samples or the collection of groundwater samples from existing monitoring wells. "Periodic" monitoring during sample collection might reasonably consist of taking a reading upon arrival at a sample location, monitoring while opening a well cap or

overturning soil, monitoring during well baling/purging, and taking a reading prior to leaving a sample location. In some instances, depending upon the proximity of potentially exposed individuals, continuous monitoring may be required during sampling activities. Examples of such situations include groundwater sampling at wells on the curb of a busy urban street, in the midst of a public park, or adjacent to a school or residence.

VOC Monitoring, Response Levels, and Actions

Volatile organic compounds (VOCs) must be monitored at the downwind perimeter of the immediate work area (i.e., the exclusion zone) on a continuous basis or as otherwise specified. Upwind concentrations should be measured at the start of each workday and periodically thereafter to establish background conditions, particularly if wind direction changes. The monitoring work should be performed using equipment appropriate to measure the types of contaminants known or suspected to be present. The equipment should be calibrated at least daily for the contaminant(s) of concern or for an appropriate surrogate. The equipment should be capable of calculating 15-minute running average concentrations, which will be compared to the levels specified below.

1. If the ambient air concentration of total organic vapors at the downwind perimeter of the work area or exclusion zone exceeds 5 parts per million (ppm) above background for the 15-minute average, work activities must be temporarily halted and monitoring continued. If the total organic vapor level readily decreases (per instantaneous readings) below 5 ppm over background, work activities can resume with continued monitoring.

2. If total organic vapor levels at the downwind perimeter of the work area or exclusion zone persist at levels in excess of 5 ppm over background but less than 25 ppm, work activities must be halted, the source of vapors identified, corrective actions taken to abate emissions, and monitoring continued. After these steps, work activities can resume provided that the total organic vapor level 200 feet downwind of the exclusion zone or half the distance to the nearest potential receptor or residential/commercial structure, whichever is less - but in no case less than 20 feet, is below 5 ppm over background for the 15-minute average.

3. If the organic vapor level is above 25 ppm at the perimeter of the work area, activities must be shutdown.

4. All 15-minute readings must be recorded and be available for State (DEC and NYSDOH) personnel to review. Instantaneous readings, if any, used for decision purposes should also be recorded.

Particulate Monitoring, Response Levels, and Actions

Particulate concentrations should be monitored continuously at the upwind and downwind perimeters of the exclusion zone at temporary particulate monitoring stations. The particulate monitoring should be performed using real-time monitoring equipment capable of measuring particulate matter less than 10 micrometers in size (PM-10) and capable of integrating over a period of 15 minutes (or less) for comparison to the airborne particulate action level. The equipment must be equipped with an audible alarm to indicate exceedance of the action level. In addition, fugitive dust migration should be visually assessed during all work activities.

1. If the downwind PM-10 particulate level is 100 micrograms per cubic meter (mcg/m^3) greater than background (upwind perimeter) for the 15-minute period or if airborne dust is observed leaving the work area, then dust suppression techniques must be employed. Work may continue with dust suppression techniques provided that downwind PM-10 particulate levels do not exceed $150 \text{ mcg}/\text{m}^3$ above the upwind level and provided that no visible dust is migrating from the work area.

2. If, after implementation of dust suppression techniques, downwind PM-10 particulate levels are greater than $150 \text{ mcg}/\text{m}^3$ above the upwind level, work must be stopped and a re-evaluation of activities initiated. Work can resume provided that dust suppression measures and other controls are successful in reducing the downwind PM-10 particulate concentration to within $150 \text{ mcg}/\text{m}^3$ of the upwind level and in preventing visible dust migration.

3. All readings must be recorded and be available for State (DEC and NYSDOH) and County Health personnel to review.

December 2009

Appendix 1B

Fugitive Dust and Particulate Monitoring

A program for suppressing fugitive dust and particulate matter monitoring at hazardous waste sites is a responsibility on the remedial party performing the work. These procedures must be incorporated into appropriate intrusive work plans. The following fugitive dust suppression and particulate monitoring program should be employed at sites during construction and other intrusive activities which warrant its use:

1. Reasonable fugitive dust suppression techniques must be employed during all site activities which may generate fugitive dust.
2. Particulate monitoring must be employed during the handling of waste or contaminated soil or when activities on site may generate fugitive dust from exposed waste or contaminated soil. Remedial activities may also include the excavation, grading, or placement of clean fill. These control measures should not be considered necessary for these activities.
3. Particulate monitoring must be performed using real-time particulate monitors and shall monitor particulate matter less than ten microns (PM10) with the following minimum performance standards:
 - (a) Objects to be measured: Dust, mists or aerosols;
 - (b) Measurement Ranges: 0.001 to 400 mg/m³ (1 to 400,000 :ug/m³);
 - (c) Precision (2-sigma) at constant temperature: +/- 10 :g/m³ for one second averaging; and +/- 1.5 g/m³ for sixty second averaging;
 - (d) Accuracy: +/- 5% of reading +/- precision (Referred to gravimetric calibration with SAE fine test dust (mmd= 2 to 3 :m, g= 2.5, as aerosolized);
 - (e) Resolution: 0.1% of reading or 1g/m³, whichever is larger;
 - (f) Particle Size Range of Maximum Response: 0.1-10;
 - (g) Total Number of Data Points in Memory: 10,000;
 - (h) Logged Data: Each data point with average concentration, time/date and data point number
 - (i) Run Summary: overall average, maximum concentrations, time/date of maximum, total number of logged points, start time/date, total elapsed time (run duration), STEL concentration and time/date occurrence, averaging (logging) period, calibration factor, and tag number;
 - (j) Alarm Averaging Time (user selectable): real-time (1-60 seconds) or STEL (15 minutes), alarms required;
 - (k) Operating Time: 48 hours (fully charged NiCd battery); continuously with charger;
 - (l) Operating Temperature: -10 to 50° C (14 to 122° F);
 - (m) Particulate levels will be monitored upwind and immediately downwind at the working site and integrated over a period not to exceed 15 minutes.
4. In order to ensure the validity of the fugitive dust measurements performed, there must be appropriate Quality Assurance/Quality Control (QA/QC). It is the responsibility of the remedial party to adequately supplement QA/QC Plans to include the following critical features: periodic instrument calibration, operator training, daily instrument performance (span) checks, and a record keeping plan.
5. The action level will be established at 150 ug/m³ (15 minutes average). While conservative,

this short-term interval will provide a real-time assessment of on-site air quality to assure both health and safety. If particulate levels are detected in excess of 150 ug/m³, the upwind background level must be confirmed immediately. If the working site particulate measurement is greater than 100 ug/m³ above the background level, additional dust suppression techniques must be implemented to reduce the generation of fugitive dust and corrective action taken to protect site personnel and reduce the potential for contaminant migration. Corrective measures may include increasing the level of personal protection for on-site personnel and implementing additional dust suppression techniques (see paragraph 7). Should the action level of 150 ug/m³ continue to be exceeded work must stop and DER must be notified as provided in the site design or remedial work plan. The notification shall include a description of the control measures implemented to prevent further exceedances.

6. It must be recognized that the generation of dust from waste or contaminated soil that migrates off-site, has the potential for transporting contaminants off-site. There may be situations when dust is being generated and leaving the site and the monitoring equipment does not measure PM₁₀ at or above the action level. Since this situation has the potential to allow for the migration of contaminants off-site, it is unacceptable. While it is not practical to quantify total suspended particulates on a real-time basis, it is appropriate to rely on visual observation. If dust is observed leaving the working site, additional dust suppression techniques must be employed. Activities that have a high dusting potential--such as solidification and treatment involving materials like kiln dust and lime--will require the need for special measures to be considered.

7. The following techniques have been shown to be effective for the controlling of the generation and migration of dust during construction activities:

- (a) Applying water on haul roads;
- (b) Wetting equipment and excavation faces;
- (c) Spraying water on buckets during excavation and dumping;
- (d) Hauling materials in properly tarped or watertight containers;
- (e) Restricting vehicle speeds to 10 mph;
- (f) Covering excavated areas and material after excavation activity ceases; and
- (g) Reducing the excavation size and/or number of excavations.

Experience has shown that the chance of exceeding the 150ug/m³ action level is remote when the above-mentioned techniques are used. When techniques involving water application are used, care must be taken not to use excess water, which can result in unacceptably wet conditions. Using atomizing sprays will prevent overly wet conditions, conserve water, and provide an effective means of suppressing the fugitive dust.

8. The evaluation of weather conditions is necessary for proper fugitive dust control. When extreme wind conditions make dust control ineffective, as a last resort remedial actions may need to be suspended. There may be situations that require fugitive dust suppression and particulate monitoring requirements with action levels more stringent than those provided above. Under some circumstances, the contaminant concentration and/or toxicity may require additional monitoring to protect site personnel and the public. Additional integrated sampling and chemical analysis of the dust may also be in order. This must be evaluated when a health and safety plan is developed and when appropriate suppression and monitoring requirements are established for protection of health and the environment.

Appendix 1C

DEC Permits Subject to Exemption

In accordance with section 1.10, exemptions from the following permit programs may be granted to the person responsible for conducting the remedial programs undertaken pursuant to section 1.2:

- Air - Title 5 permits
- Air - State permits
- Air - Registrations
- Ballast Discharge
- Chemical Control
- Coastal Erosion Hazard Areas
- Construction of Hazardous Waste Management Facilities
- Construction of Solid Waste Management Facilities
- Dams
- Excavation and Fill in Navigatable Waters (Article 15)
- Flood Hazard Area Development
- Freshwater Wetland
- Hazardous Waste
- Long Island Wells
- Mined Land Reclamation
- Navigation Law - Docks
- Navigation Law - Floating Objects
- Navigation Law - Marinas
- Non-Industrial Waste Transport
- Operation of Solid Waste Management Facilities
- Operation of Hazardous Waste Management Facilities
- State Pollution Discharge Elimination Systems (SPDES)
- Stream Disturbance
- Tidal Wetlands
- Water Quality Certification
- Water Supply
- Wild, Scenic and Recreational Rivers

**Remedial Action Work Plan
Area E
Former Buffalo Color Corporation**

C - Storm Water Pollution Prevention Plan (See Sheets)

**Remedial Action Work Plan
Area E
Former Buffalo Color Corporation**